

FEATURES

- Forged brass manifold
- Die-cast anodized aluminum, oil-bath crankcase
- Solid ceramic plungers with continuously lubricated packings
- The original Interpump unitized, stainless steel, K01 inlet and outlet valves
- Ideal for all general cleaning, RO and misting applications
- Comes standard with 24 mm solid shaft for pulley mount or direct drive with flex coupler and bell housing
- Also available in "L" left-handed versions



SPECIFICATIONS

Pump Model	TT901	TT931	TT941	TT951	TT9111
Maximum Volume	2.11 GPM	2.9 GPM	3.43 GPM	2.5 GPM	3.0 GPM
Maximum Discharge Pressure	1500 PSI				
Maximum Pump Speed	2800 RPM				1750 RPM
Maximum Inlet Pressure	125 PSI				
Minimum Inlet Pressure	3 ft. water (2.6 in. Hg)				
Plunger Bore (in / mm)	.591 / 15				.708 / 18
Plunger Stroke (in / mm)	.236 / 6	.315 / 8	.370 / 9.4	.283 / 7.2	.370 / 9.4
Oil Capacity	11.2 oz.				
Maximum Fluid Temperature	165° F				
Inlet Port Thread	3/8-19 BSP-F				
Discharge Port Thread	1/4-19 BSP-F				
Shaft Diameter	.945 in. / 24 mm				
Weight	11.2 lbs.				
Dimensions	7.0" x 6.9" x 5.1"				

DIMENSIONAL DRAWING

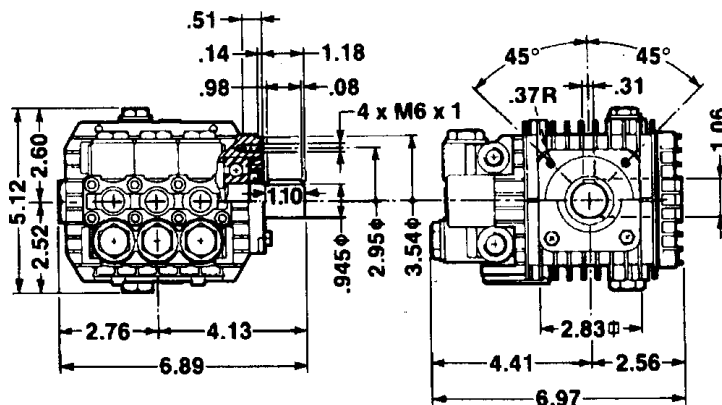

Ref 300296 Rev. G
06-22



General Pump
is a member of
the Interpump Group



TT Series 51, Solid

GENERAL PUMP *A member of the Interpump Group*

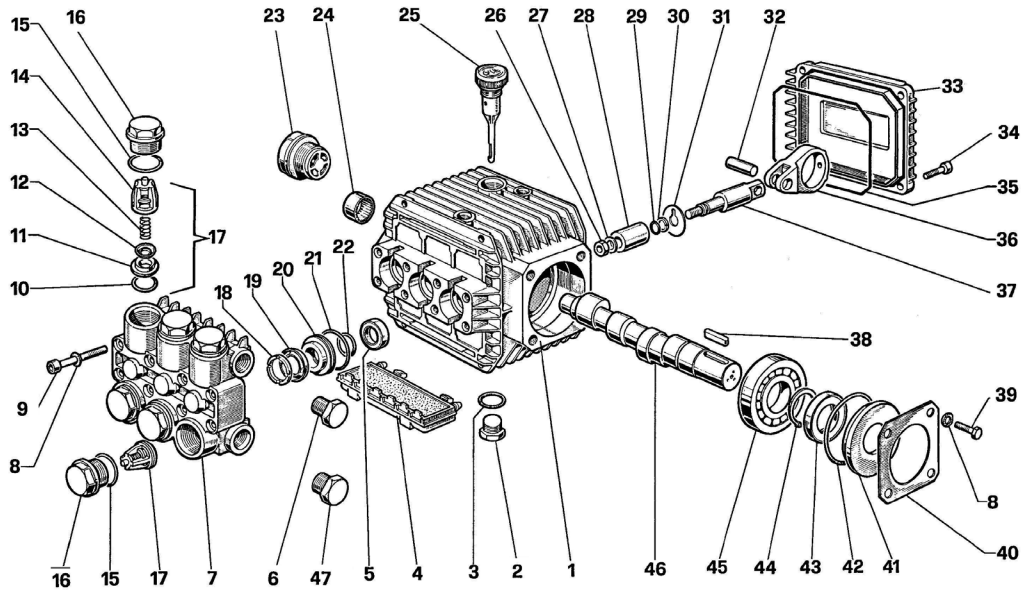

PARTS LIST

ITEM	PART NO.	DESCRIPTION	QTY.	ITEM	PART NO.	DESCRIPTION	QTY.	ITEM	PART NO.	DESCRIPTION	QTY.
1.	51010622	Crankcase	1	18.	51100051	Head Ring, 15 mm	3	33.	51160022	Crankcase Cover	1
2.	98210050	Plug, 3/8-BSP	1		51100151	Head Ring, 18mm	3	34.	99186700	Screw, M6 x 18	4
3.	90383300	O-ring, Ø 13.95 x 2.62	2	19.	90262000	Packing	3	35.	90391700	Gasket	1
4.	51209151	Protector	1		90268100	Packing, 18mm	3	36.	51030022	Connecting Rod End	3
5.	710002	Oil Seal	3	20.	51080070	Packing Retainer	3	37.	51050056	Piston Guide	3
6.	98204100	Plug, 1/4 BSP	2	21.	90360400	O-ring	3	38.	91487800	Key	1
7.	51120022	Manifold, Nick., 15mm	1	22.	90383500	O-ring, 15 mm	3	39.	99180700	Screw, M6x10	4
	51120041	Manifold, Brass, 15mm	1		90384300	O-ring, 18mm	3	40.	50150074	Side Bearing Cover	1
	51120441	Manifold, Brass, 18mm	1	23.	97596800	Sight Gauge	1	41.	50211551	Spacer	1
8.	203510	Washer, M6.4	8	24.	91801500	Needle Bearing	1	42.	90409700	O-ring, Ø55.56x3.53	1
9.	99194300	Screw, M6 x 40	8	25.	98210300	Oil Dip Stick	1	43.	90163500	Rad. Ring, Ø25x42x7	1
10.	70115	O-ring, Ø17.13x2.62	6	26.	92221600	Nut, M8	3	44.	90063500	Circlip	1
11.	36200366	Valve Seat	6	27.	44211570	Washer, M8	3	45.	91832800	Bearing	1
12.	36711501	Valve Plate	6	28.	51040009	Plunger, 15 mm	3	46.	51020065	Crankshaft (TT901)	1
13.	94737600	Spring	6		51040109	Plunger, 18mm	3		51021765	Crankshaft (TT951)	1
14.	36200251	Valve Cage	6	29.	90357300	O-ring	3		51020465	Crankshaft (TT941)	1
15.	701002	O-ring	6	30.	660024	Back-up Ring	3		51020165	Crankshaft (TT931)	1
16.	98221800	Valve Cap	6	31.	96707000	Washer, Flinger	3	47.	98210000	Plug, 3/8 BSP	1
17.	100381	Valve Assembly	6	32.	97731000	Connecting Rod Pin	3				

REPAIR KITS

KIT NO.	1	83	84	86 (15 mm)	96 (15mm)	97 (15mm)	139 (18mm)	140 (18mm)	141 (18mm)
ITEM NO's INCLUDED IN KIT	10, 11, 12, 13, 14 (17)	5	15, 16	20, 21, 22	18, 19, 20, 21, 22	18, 19, 21, 22	20, 21, 22	18, 19, 20, 21, 22	18, 19, 21, 22
NUMBER OF ASSEMBLIES IN KIT	6	3	6	3	1	3	3	1	3
NUMBER OF CYLINDERS KIT WILL SERVICE	3	3	3	3	1	3	3	1	3

TORQUE SPECS*

Position	Ft. Lbs.	Nm
2	29.5	40
6	14.8	20
9	8.9	12
16	44.3	60
23	8.9	12
26	14.8	20
34	7.4	10
39	7.4	10
47	29.5	40

* Decrease torque by 20% if threads are lubricated

WARNING: High Pressure Systems require a primary pressure regulating device (i.e. regulator, unloader) and a secondary pressure relief device (i.e. pop-off valve, relief valve). Failure to install such relief devices properly could result in personal injury or damage to pump or property. GP does not assume any liability or responsibility for the operation of the user's high pressure system.



WARNING: This product can expose you to chemicals including lead, which is known to the state of California to cause cancer and birth defects or other reproductive harm. For more information, go to www.P65Warnings.ca.gov