

SANDBLASTING HEAD and SAND POKER



SPECIFICATIONS

Part Number	ZMSNDBLST 0,1,2,3,4,5
Working Pressure	1000 - 3000 PSI
Volume	2.1 - 13.2 GPM
Sand Consumption	460 - 860 lbs/hr
Max Water Temp	158° F
Max Hose Length	20 ft
Weight	1 lb
Dimensions	7.0 x 1.3 x 2.5 in.
Part Number	ZMSNDPOKER
Weight	.3 lb
Dimensions	16.3 x Ø1.0 in

Parts List

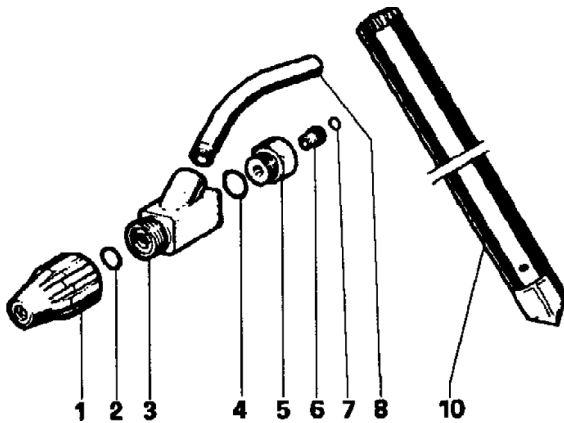

No.	Part No.	Description	Qty.
1	10705001	Knob	1
2	90382800	O-Ring	1
3	10706201	Body	1
4	90359300	O-Ring	1
5	10012970	Inlet	1
6	10014166	Nozzle, #0, Ø1.5 mm	1
	10013366	Nozzle, #1, Ø1.6 mm	1
	10013466	Nozzle, #2, Ø1.7 mm	1
	10013566	Nozzle, #3, Ø1.85 mm	1
	10014066	Nozzle, #4, Ø2.1 mm	1
	10033066	Nozzle, #5, Ø2.3 mm	1
7	90357600	O-Ring	1
8	10013789	Tube Fitting	1
10	ZMSNDPOKER	Sand Poker	1

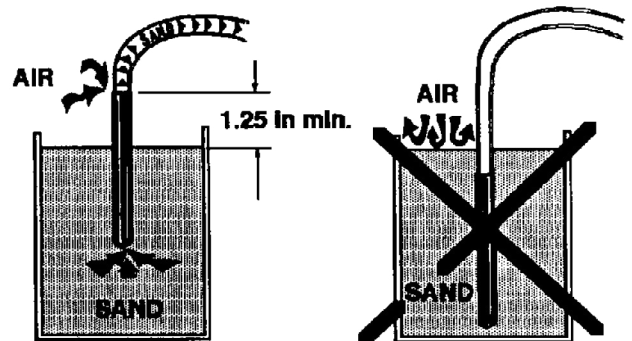

Tube fitting must be positioned upright.

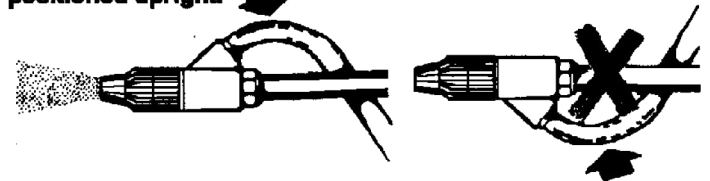

WARNING:

- Use proper eye and skin protection
- Do not direct spray at yourself or any other person
- Keep hands clear or spray nozzle

Place sand probe in sand leaving at least 1.25 inches above sand level to allow air flow to carry the sand. The sandblast head tube fitting (item #8) must be upright when spraying for proper mixing and flow of sand.