



FEATURES

- Relieves pressure of the system by releasing excess volume through the discharge
- Protects the system from over pressurization
- Manually adjustable
- Includes provisions for safety (tamper wire) (not included)

SPECIFICATIONS

Part Number	ZKS284
Flow Rate	1.9 - 10.8 GPM
Set Pressure Range	725 - 4930 PSI
Maximum Temperature	185° F
Port Sizes: Inlet	R3/8" BSPT
Discharge	Side - Hose Barb - 10mm
Weight	0.5 lbs.

DIMENSIONS

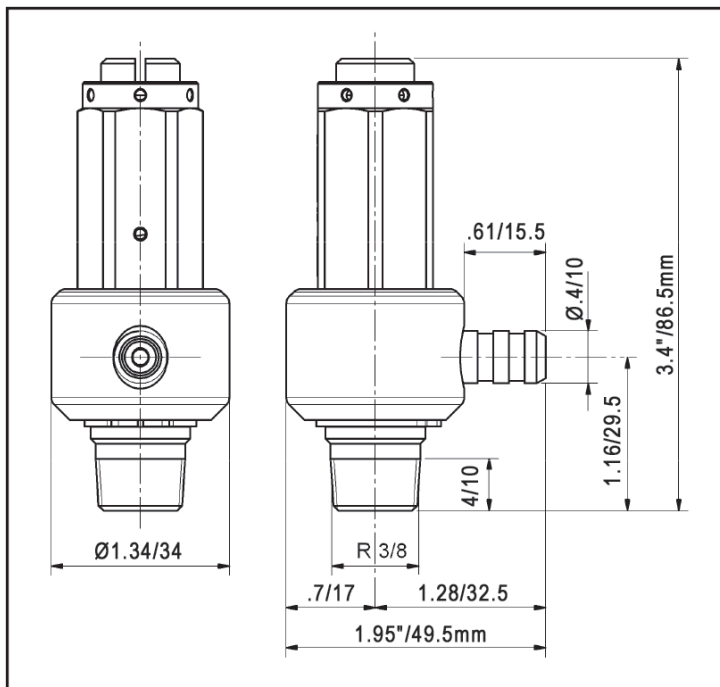

ATTENTION: Safety valves are set 15 to 20% above the maximum operating pressure of the system. The real cracking pressure of a S723/300 (for example) is 4,350 PSI plus 20% = 5,220 PSI.

When ordering, always refer to the maximum operating pressure, we will set the cracking pressure accordingly (15 to 20% higher).

PARTS LIST

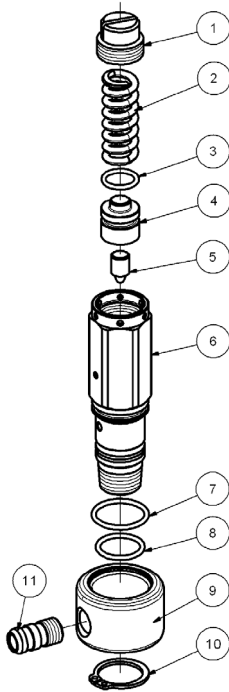

Item No.	Part No.	Description	QTY.
1	36261570	Adjustment Screw	1
2	94739600	Spring, Ø11.2x36, SS	1
3	90358700	O-ring, Ø11.11v1.78	1
4	36261870	Piston	1
5	36261782	Piston Insert, Composite	1
6	36261670	Body	1
7	90359700	O-ring, Ø18.77x1.78	1
8	90359300	O-ring, Ø15.60x1.78	1
9	36262170	Ring	1
10	90059000	Snap Ring	1
11	36262271	Hose Barb	1

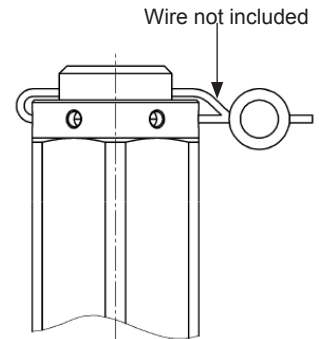

Seal Detail

1. GENERAL INFORMATION

1.1 The ZKS284 relief valve is a manually adjustable pressure-operated device which, according to its setting releases the excess of water when the pressure inside the pump/system exceeds the adjusted value, thus reducing the pressure. The normal working conditions can be restored by turning off and then restarting the system.

1.2 Since the ZKS284 is used in connection with a high pressure water pump/system, which shall be called hereafter only "system", installation and use must be suited to the type of system used and comply with the safety regulations in force in the country where the valve is used.

1.3 Before using the valve, make sure the system the valve is used with is certified to comply with the relevant directives and/or regulations.

1.4 Before installing and using the valve for the first time, we suggest you check that it is undamaged and make sure that the rated features correspond to the required ones. If this is not the case, do not use the valve and contact General Pump Customer Service.

2. PACKAGE

2.1 Packages must be handled in compliance with the instructions stated on the packages themselves and/or provided by the manufacturer.

2.2 In case the valve is not used immediately, it must be stored in its integral package and placed in areas which are not exposed to the weather and protected from excessive humidity and from direct sunlight. Moreover, it is advisable to place wooden pallets or other typed of pallets between the package and the floor, in order to prevent the direct contact with the ground.

2.3 The package components must be disposed of in compliance with the relative laws in force.

3 INSTRUCTION FOR INSTALLATION AND PRESSURE SETTING

3.1 The installation and the pressure setting must be made by qualified and authorized staff only, who must have the required skills to handle high pressure systems and be informed of the operating and safety instructions contained in this document.

3.2 In order to determine the setting pressure of the ZKS284 valve, it is necessary to equip the high pressure feeding line of the system also with a pressure regulator.

3.3 The setting pressure is the pressure at which the valve opens, thus determining the maximum pressure value that the system cannot exceed.



IMPORTANT: the value of the setting pressure is to be within the pressure range stated in the table of technical features.

3.4 Pressure Setting:

3.4.1 Connect the ZKS284 valve and the pressure regulator to the water system.

3.4.2 Loosen the adjustment screw (pos. 1) of the ZKS284 valve in order to completely release the spring.

3.4.3 Open the gun or the water control device and start the system. Make sure that the air contained in it is fully ejected.

3.4.4 Slightly screw down the adjustment screw (pos. 1).

INSTRUCTIONS FOR USE (CONT.)

3.4.5 Keeping the gun or the water control device open, slowly increase the pressure in the system by using the pressure regulator.

3.4.6 Check the pressure value at which the ZKS284 valve opens releasing the system of excess water.

3.4.7 Perform the steps 3.4.4, 3.4.5, and 3.4.6 again until the desired setting pressure is achieved.

3.4.8 When the desired pressure has been reached, open the gun/control device a few times again in order to stabilize the various components (seals, spring, etc.). Check the pressure value again and correct if necessary.

3.4.9 Once the setting has been accomplished, we suggest you seal the adjustment screw in order to avoid any unintentional variation of the pressure and indicate on the valve itself the actual value of the setting pressure that has just been determined.

3.4.10 During the normal functioning of the system, the maximum working pressure (WP) should be kept within approx. 85% of the setting pressure of the valve (SP).

General Pump disclaims all responsibility for any damages cause by the inaccurate adjustment of the setting pressure an/or by any incorrect use of the valve that cannot be reasonably predicted.



IMPORTANT: During use, never exceed the maximum values of pressure, flow-rate and temperature as stated in this document and/or indicated on the valve.

4 WARNINGS

4.1 The installer must provide the ultimate consumer with the proper instructions for the correct use of the system the valve will be used in connection with.

4.2 The fittings used to connect the valve to the system must be suited to the valve performance features. **IMPORTANT:** to obtain an effective functioning of the valve, we suggest you install it by the component or in the system section that you wish to protect most from pressure peaks.

4.3 Use soft and filtered water only. In case of salt water and/or of water containing solid particles of a size exceeding 360 µm, the internal components of the valve will be subject to quick wear; furthermore this might compromise the correct functioning of the valve. Additional agents can be used in the water, provided that they are delicate, biodegradable and always complying with the regulations in force in the country where the valve is used.

4.4 In the systems for hot water productions the temperature of the liquid that comes into contact with the valve must always be lower than the value stated in this instruction manual and indicated on the valve itself. **Avoid the formation of steam or overheated water.**



IMPORTANT: When the temperature of the liquid is close to the maximum value, the outside temperature of the valve body may become hot. Therefore, take care in case of contact with the hot surfaces.

4.5 Before operating the system, it is advisable to start it for a preliminary test run in order to check that the system is properly installed.



4.6 IMPORTANT: Do not obstruct the outlet port for any reason. To convey the water, use a flexible hose holder and locked by means of a clamp. Always release in the atmosphere. Failure to comply with these instructions will result in a reduced safety of the system.

4.7 To fix the valve, manually screw the R3/8" tapered thread fitting, then apply another 2-3 turns by means of a wrench to tighten it completely. If necessary, a proper sealant can be used in order to ensure the thread seal.

4.8 Should the relief valve open, turn off the system and find out what is the cause of the pressure increase.

WARNING: Do not use the valve in the systems covered by Directive 97/23/CE (PED) - Categories I-II-III-IV.

5. MAINTENANCE

5.1 Any maintenance and/or repair must be carried out by General Pump **ONLY**.



5.2 We suggest you check, at least every 2 years of or after reaching 500 working hours of the system, that the valve opens correctly in order to verify the correspondence with the setting pressure.

5.3 The valve is entirely made of non-toxic and safe materials; however, in case of disposal, we suggest you do not disperse it in the environment but take it to an authorized disposal center.



IMPORTANT: The valve shall not be tampered with for any reason and/or used for any purpose other than the use it has been designed for. In case of tampering, the manufacturer disclaims all responsibility as to the valve functioning and safety.

6. WARRANTY CONDITIONS

6.1 The period and conditions of warranty are specified in the purchase contract.

6.2 Warranty is voided in case the valve is used for improper purposes, used at higher performances than the rated ones, repaired with non-original spare parts or if it turns out to be damaged due to the non-compliance with the operating instructions or to unauthorized tampering.