

GENERAL PUMP *A member of the Interpump Group*



YVB8KMS

Trapped Pressure Unloader w/Microswitch

SPECIFICATIONS

Part Number:	YVBKMS
Maximum Volume	8.0 GPM
Rated Pressure	3200 PSI
Maximum Pressure	3650 PSI
Maximum Temperature	195° F
Port Sizes:	
Inlet	3/8" BSP-M
Outlet	3/8" BSP-F
Bypass	3/8" BSP-F
Gauge	1/4" F
Overall Dimemsions	10" x 5" x 2.3"
Weight	2.0 lbs.
Pressure Switch	
Amperage	2 amp ind. 6 amps res.
Volts	250 volts
Lead Length	40"
Materials	Brass, Stainless, Plastic, Buna-N

FEATURES

- Extremely durable unloader with microswitch
- Waterproof, 6 Amp pressure switch

PARTS LIST

Item	Part No.	Description	QTY
*	Y60121224	Spare Parts Kit	1
1	Y60005831	Delivery couple, 3/8" F, brass	1
2*	700023	O-ring, 1.78x18.77 mm	2
3	Y60005351	Spring, 0.7x9x20. SST	1
4	Y60005231	Shutter pin, brass	1
5*	Y10321300	O-ring, 3x6 mm	1
6	Y60120135	Housing, 3/8 M, c/sunk, brass	1
7*	Y10317008	O-ring, 2.62x7.6 mm	1
8	Y60120631	Pison, M6, brass	1
9*	Y10300101	O-ring, 1x4 mm	1
10*	Y10306601	O-ring, 1.78x15.6 mm	1
11	Y60120531	Nut, M6, brass	1
12*	Y60222120	Seal, 10 mm, +O-ring, 1.78mm=shutt	1
13*	Y10402100	Back up ring, opn 11.5x15x12mm	2
14*	Y10317500	O-ring, 2.62x10.77mm	1
15	Y60120432	Spring rest pin, brass	1
16*	Y10316701	O-ring, 2.62x5.23mm	1
17	Y60120331	Piston holder, brass	1
18	Y16210000	Set screw, DIN914, M4x4	1
19	Y60170431	Ring Nut, M22x1, brass	1
20	Y14371900	Washer, 9x15x1.5mm, SST	1
21	Y60120861	Spring, 3.2x15x33mm	1
22	Y60121031	Spring guiding ring	1
23	Y14742100	Ball, 1/4" set	1
24	Y60120931	Valve regulating insert, brass	1
25	Y29008751	U-bolt, SST	1
26	Y29008784	Housing	1
27	Y12500600	Cable, 3x.75L 1000mm, Microswitch	1
28	Y10320601	O-ring, 2.62x28.25mm	1
29	Y16302000	S/tapping screw	2
30	Y29008884	Lid, PR5, black	1
31	Y10316900	O-ring, 2.62x6.02 mm	1
32	Y29008284	Locknut for cable gland, lbk	1
33	Y10303800	O-ring, 1.78x3.68mm	1
34	Y14351953	Washer, 4x8x.8mm, SST	1
35	Y60230351	Spring, 1.1x8x20mm, SST	1

Item	Part No.	Description	QTY
36	Y60128131	Microswitch piston, brass	1
37	Y60120284	Valve regulating knob, blk.	1
38	Y14358500	Washer, 30.5x42x2mm	1
39	Y60225431	Ring nut, M30, brass	1
40	Y29009624	Casing kit	1

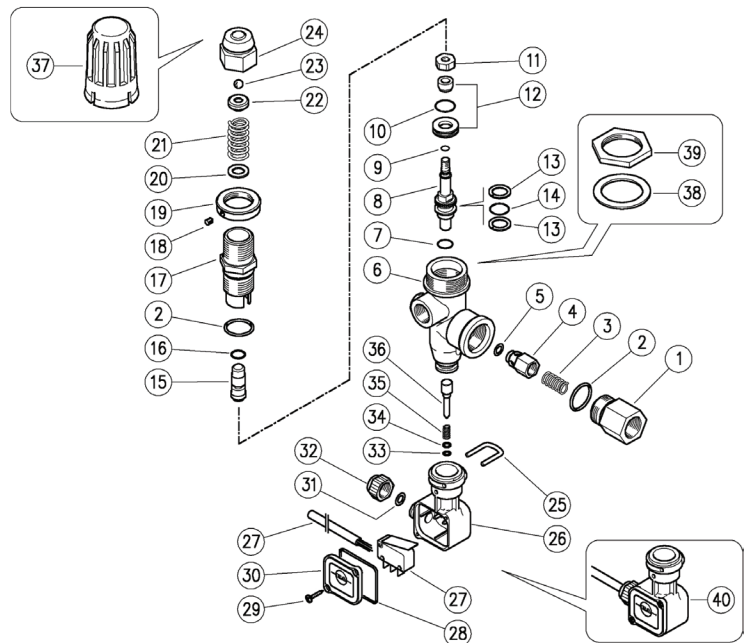

General Pump
is a member of
the Interpump Group

Ref 300639-Rev. C
09-22



TECHNICAL SPECIFICATIONS - PRESSURE SWITCH

Max rated voltage.....250v	Electrical InsulationClass IP 55
Breaking switch 6 amp - resistive load / 2 amp - inductive load	
Electrical wire 3 x 075mm ² (3 wire - 19 gauge)	Length of cable.....1000mm (40")
Room temperature 75° C (165° F)	
Electrical Component life..... 50,000 cycles, Temp 85° C at 250 VAC	Type of action.....1C

TROUBLE SHOOTING

PROBLEMS	PROBABLE CAUSES	SOLUTIONS
Unloader Cycles	Damaged discharge check valve Leaking fittings or gun Restricted bypass	Replace Check and renew Clean or adapt
Electric signal missing	Disconnected wires Drive pin too short	Connect firmly Adjust nut and ball holder
Unloader does not come up to pressure	Unloader not properly sized Debris lodged in unloader Unloader piston o-ring worn Worn nozzle	Select proper unloader Clean unloader Replace Replace
Excessive pressure spikes	Unloader improperly adjusted There is not a minimum of 5% flow in bypass	Adjust unloader Adjust unloader
Unloader won't go into bypass	Discharge check valve jammed Worn discharge check valve o-ring Debris in unloader valve	Clean or replace Replace Clean unloader

DIMENSIONAL DRAWING

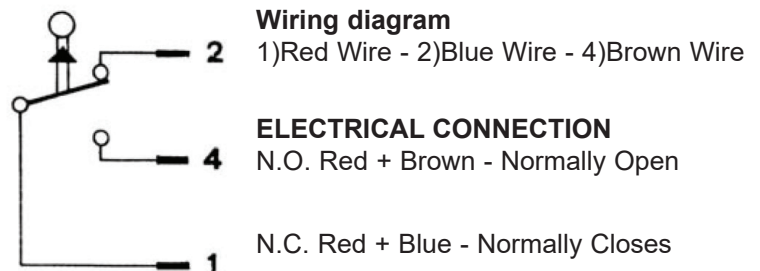
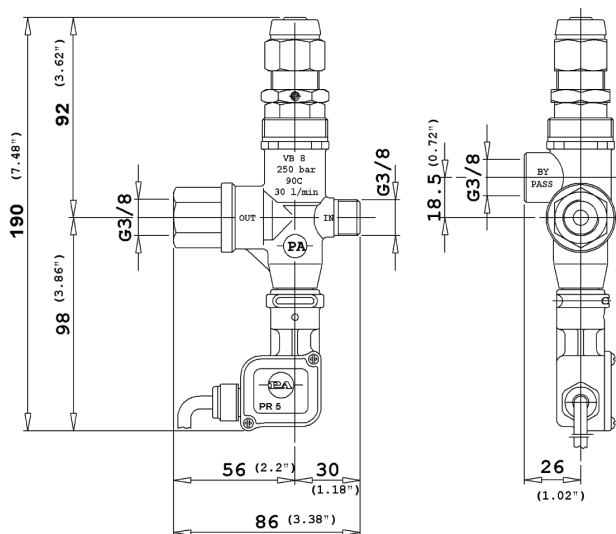

Ref 300639 Rev. C
09-22