



**FEATURES**

- Suitable for high flow rates, perfect for GP's HTCK Series
- Dynamic seals made up of O-ring and back-up ring
- Optimized internal passages that guarantee reduced pressure loss
- Can be used in multiple gun situations
- Easy maintenance

**SPECIFICATIONS**

<b>Part Number</b>	<b>YU3723</b>	
Maximum Volume	37 GPM	
Rated Pressure	2,300 PSI	
Maximum Pressure	2,600 PSI	
Maximum Temperature	140° F	
Note: The valve has been designed for continuous use at a water temperature of 140° F. It can operate for short periods at a maximum temperature of 195° F.		
Port Sizes	Inlet:	3/4" NPT-F
	Outlet:	3/4" NPT-F
	Bypass:	3/4" NPT-F
Overall Dimension	8.71" x 4.86" x 1.5"	
Weight	4.0 Lbs.	

*General Pump recommends using a safety relief device in conjunction with this unloader valve when installed on a positive displacement pump. General Pump is not liable and assumes no responsibility when used in a customer's high pressure system.*

**PARTS LIST**

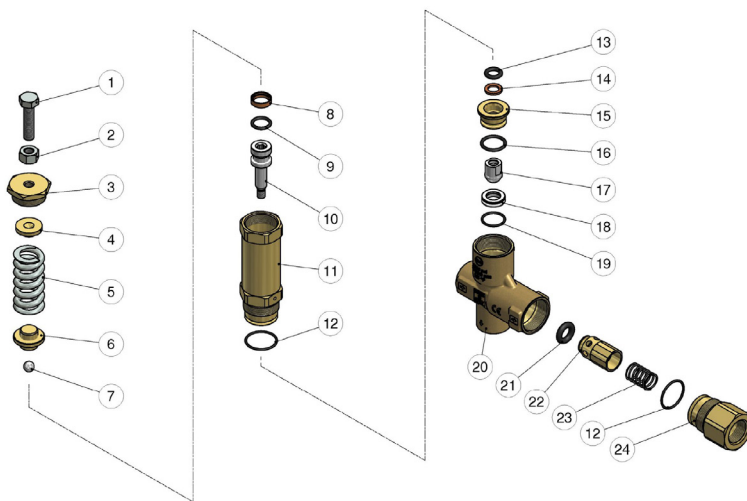

No.	Part No.	Description	Qty.
1	Y30501161	Valve Regulating Screw	1
2	Y11462900	Hex Nut	1
3	Y60500831	Upper Plug	1
4	Y60500731	Spring Guide Spacer	1
5	Y60500661	Spring, 6x30x62	1
6	Y60430431	Spring Guide Spacer	1
7	Y14746100	Ball, 13/32"	1
8*	Y10409400	Back-up Ring	1
9*	Y10318000	O-ring, 2.62x15.08	1
10	Y60480351	Piston, M8	1
11	Y60480131	Piston Holder	1
12*	Y10307708	O-ring, 1.78x28.3	2
13*	Y10323400	O-ring, 3.53x10.69	1
14*	Y10404400	Back-up Ring, 11x17.2x2	1
15	Y60480731	Reduction Bushing	1
16*	Y10319501	O-ring, 2.62x20.29	1
17*	Y60480651	Shutter Pin	1
18*	Y60480451	Seat, 14x23x6	1
19*	Y10307201	O-ring, 1.78x20.35	1
20	Y60480835	Housing	1
21*	Y10331400	O-ring, 5.33x12.06	1
22	Y60501299	Shutter Pin + O-ring	1
23	Y60501351	Spring, 1.3x18x29	1
24	Y60480931	Coupling	1
*	Y60481224	Repair Kit	

**DIMENSIONS**

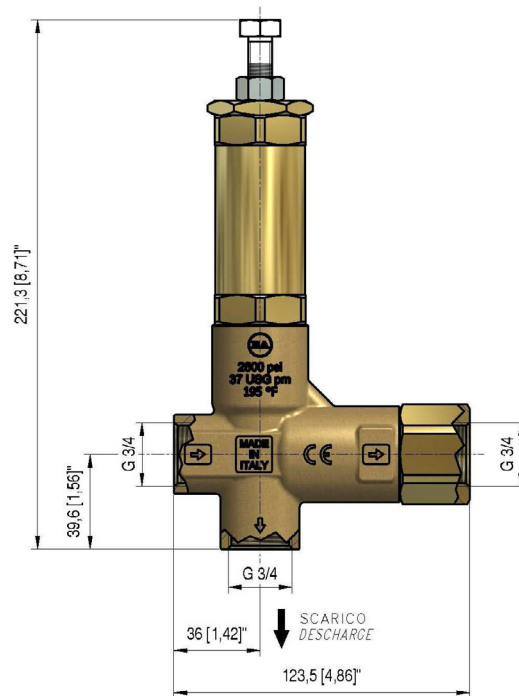

**SELECTION AND OPERATION**

**SELECTION**

This product is intended to be incorporated on a finished machine. This product is to be used with clean fresh water, for use involving different or corrosive liquids, contact the GP Customer Service Department. Appropriate filtration should be installed when using impure liquids. Choose the valve appropriate to the working data of the pump (permissible pressure, flow and rated temperature of the system). The pressure of the pump must not exceed the maximum pressure of the valve.

**OPERATION**

The valve regulates the maximum pressure of the system by varying the flow discharged by the bypass. The adjustment is made by altering, by means of a piston, the position of a sphere which partially closes the bypass opening. The valve is sensitive to water flow. At gun opening, the water flows through the valve which maintains the system in pressure until the gun closes, the interruption of the flow provokes the complete aperture of the bypass which allows to discharge the flow at low pressure. At gun closure, the special mechanism of zero setting, which does not include a check valve, keeps in connection the delivery line and the bypass line, in that way permitting to lower the pressure all around the system and not only in the source line of the valve.

**INSTALLATION**

This valve, on a system that produces hot water, must be fitted upstream from the source of heat. On a system that generates hot water, it is advisable to use accessories that limit the accidental increase of fluid temperature. **Always install a safety valve.** We recommend the use of a nozzle with flow rate which allows a regular discharge from the valve bypass of at least 5% of the flow supplied by the pump. In order to achieve a constant pressure and easy adjustment. If the nozzle wears out, the pressure decreases. To reset pressure back to working level, it is necessary to replace the worn nozzle. When a new nozzle is fitted, resetting of the system to its original working pressure is required.

**DISCHARGE SYSTEM AND WATER ADDUCTION**

The bypass discharge can be sent back to the pump intake or returned into a tank; in such cases it is advisable that the tank be fitted with baffles to reduce eventual turbulence and air bubbles which could be harmful to the pump.

**PRESSURE ADJUSTMENT/CALIBRATION**

The desired working pressure must be adjusted with the system running and the gun opened. Adjust the pressure by screwing or unscrewing the adjustment knob. The operation is easier if the correct nozzle has been chosen (see above). When screwing the adjustment nut a consequent pressure increase must be matched. If, before reaching the desired pressure, there is no pressure increase, DO NOT FORCE. Rather, check the correct ratio of nozzle/flow rate - pressure and, if necessary, replace with a smaller size nozzle.

**ATTENTION:** the nut in position 21 is a mechanical security device that limits the maximum pressure; it must absolutely NOT be removed.

**MAINTENANCE**

STANDARD: every 400 working hours, check and lubricate the seals with water resistant grease.

SPECIAL: every 800 working hours, check the wear of the seals and internal parts and, if necessary, replace with original GP parts taking care, during installation, to lubricate with water resistant grease.

**The manufacturer is not to be considered responsible for damage as a result from incorrect fitting and maintenance.**

**TROUBLESHOOTING**

PROBLEMS	PROBABLE CAUSES	SOLUTIONS
Frequent valve recycles	<ul style="list-style-type: none"><li>• Damaged check valve O-ring</li><li>• Leaking connections</li><li>• Restricted bypass or too small diameter of the bypass hose</li></ul>	<ul style="list-style-type: none"><li>• Replace</li><li>• Check or renew</li><li>• Clean or adapt passage diameter</li></ul>
Valve does not reach pressure	<ul style="list-style-type: none"><li>• Piston O-rings worn out</li><li>• Debris between seat and shutter</li><li>• Seat worn out</li><li>• Nozzle worn out</li><li>• Incorrect choice of nozzle</li></ul>	<ul style="list-style-type: none"><li>• Replace</li><li>• Clean the seat</li><li>• Replace</li><li>• Replace</li><li>• Fit with smaller nozzle</li></ul>
High pressure peaks at gun closure	<ul style="list-style-type: none"><li>• There is not a minimum of 5% of total flow discharged in bypass</li><li>• Excessive flow in bypass</li><li>• Adjustment with spring totally compressed</li></ul>	<ul style="list-style-type: none"><li>• Reset Correctly</li><li>• Change type of valve or adjust passages</li><li>• Loosen adjustment screw and eventually fit with smaller nozzle</li></ul>
Valve does not discharge at low pressure at gun closure	<ul style="list-style-type: none"><li>• Jammed check valve</li><li>• Debris on check valve</li></ul>	<ul style="list-style-type: none"><li>• Clean or replace</li><li>• Clean</li></ul>