

FEATURES

- Compact and lightweight
- Hardened steel helical gears for quiet operation
- Oil bath lubrication
- Dual bearing design for extended life
- J609 Flange mounts to most gasoline engines

SPECIFICATIONS

Part Number	YGR1125P40
Drive Ratio	2.21:1
Horsepower	up to 40 HP
Input (motor) Shaft Ø"	1.125"
Output (pump) Shaft Ø"	28 mm
Motor Flange (SAE)	J609
Pump Flange	Fits 64 EV Series General Pump
Oil Grade	SAE90 Gear Lube
Oil Capacity	17 oz
Weight	5.8 lbs.

DIMENSIONS

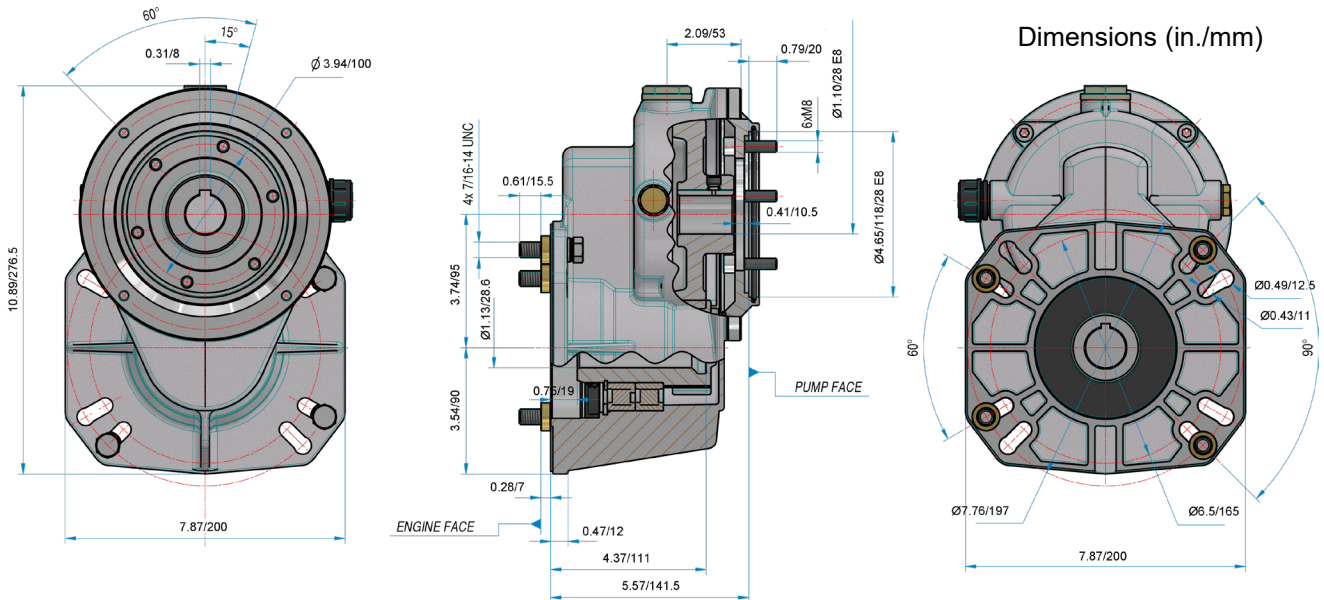

YGR1125P40

Gear Reducer

GENERAL PUMP *A member of the Interpump Group*

PARTS LIST

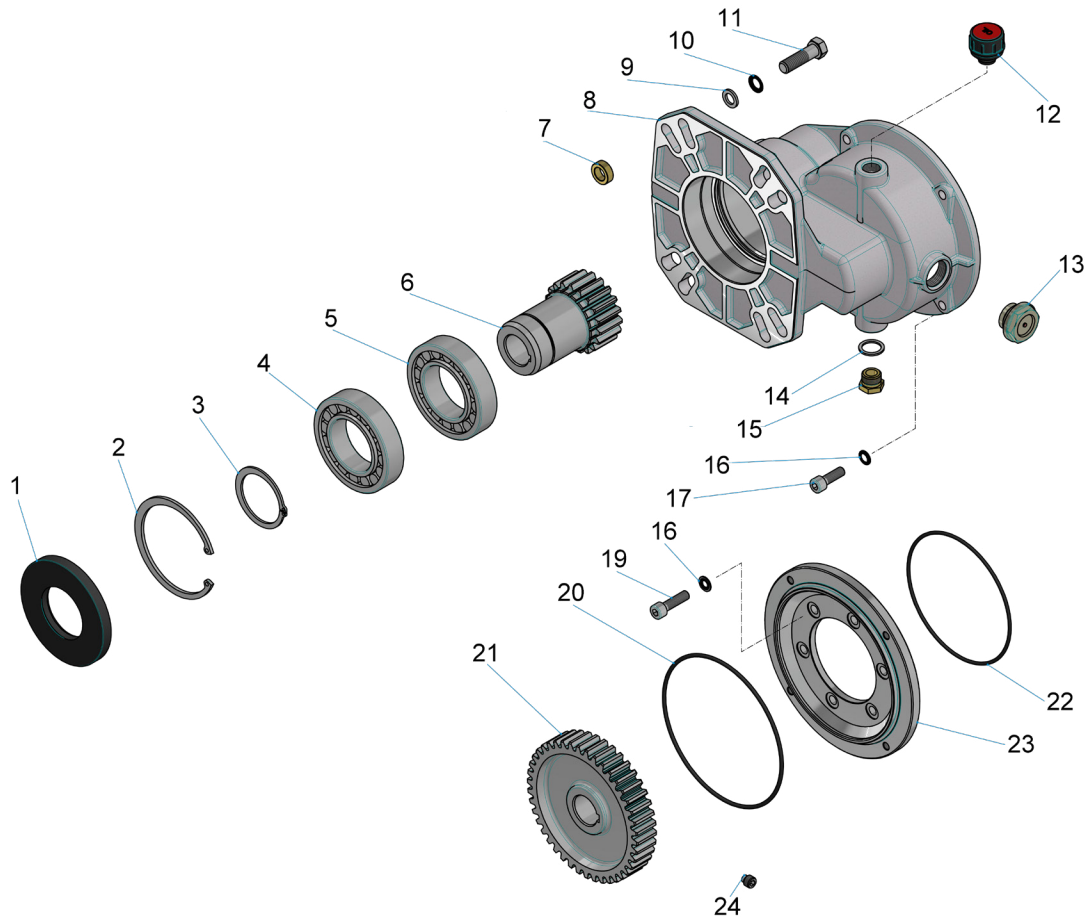

No.	Part No.	Description	QTY.
1	Y10606192	Seal	1
2	Y10109200	Retaining Ring	1
3	Y10105000	Retaining Ring	1
4	Y11445091	Bearing	1
5	Y11445090	Bearing	1
6	Y50041465	Gear	1
7	Y50041731	Spacer	1
8	Y50041144	Housing	1
9	Y14379800	Washer	4
10	Y14365300	Washer	4
11	Y16205500	Screw	4
12	Y15372600	Oil Cap	1

No.	Part No.	Description	QTY.
13	Y15373400	Oil Plug	1
14	Y14404200	Washer	1
15	Y60002831	Plug	1
16	Y14365200	Washer	4
17	Y16195826	Bolt	4
18	Y14409800	Washer	6
19	Y16195831	Bolt	6
20	Y10322000	O-ring	1
21	Y51041565	Gear	1
22	Y10321012	O-ring	1
23	Y50041241	Flange	1
24	Y16223200	Screw	1

Gear Reducer

GEARBOX INSTALLATION

The gearbox was not designed to bear weight of the pump. **The pump needs to be fixed to the frame of the machine with adequate supports.**

Supports allowing for connection of the pump towards the engine can help during the assembly process (Fig. 1.1); e.g. slotted holes (Fig. 1.2)

Anti-vibration mounts between the pump/engine and frame are recommended.

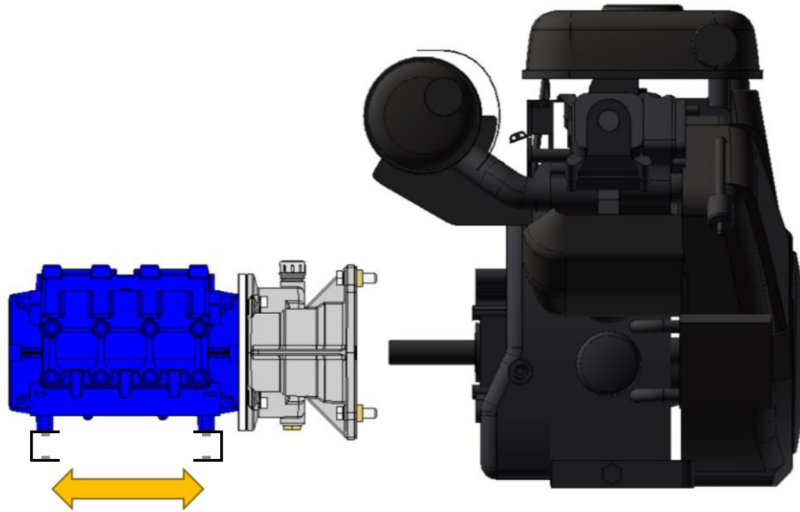

(Fig. 1.1)

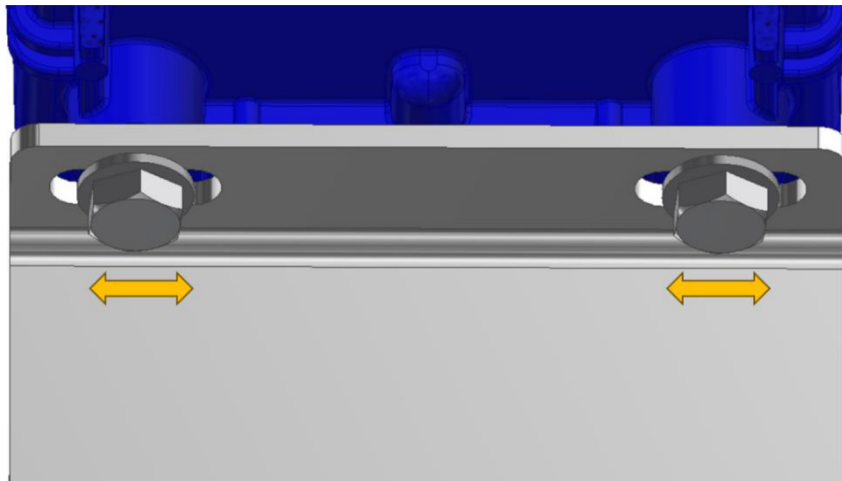

(Fig. 1.2)

YGR1125P40

Gear Reducer

Pay attention to the **direction of rotation** (Fig. 1.3)

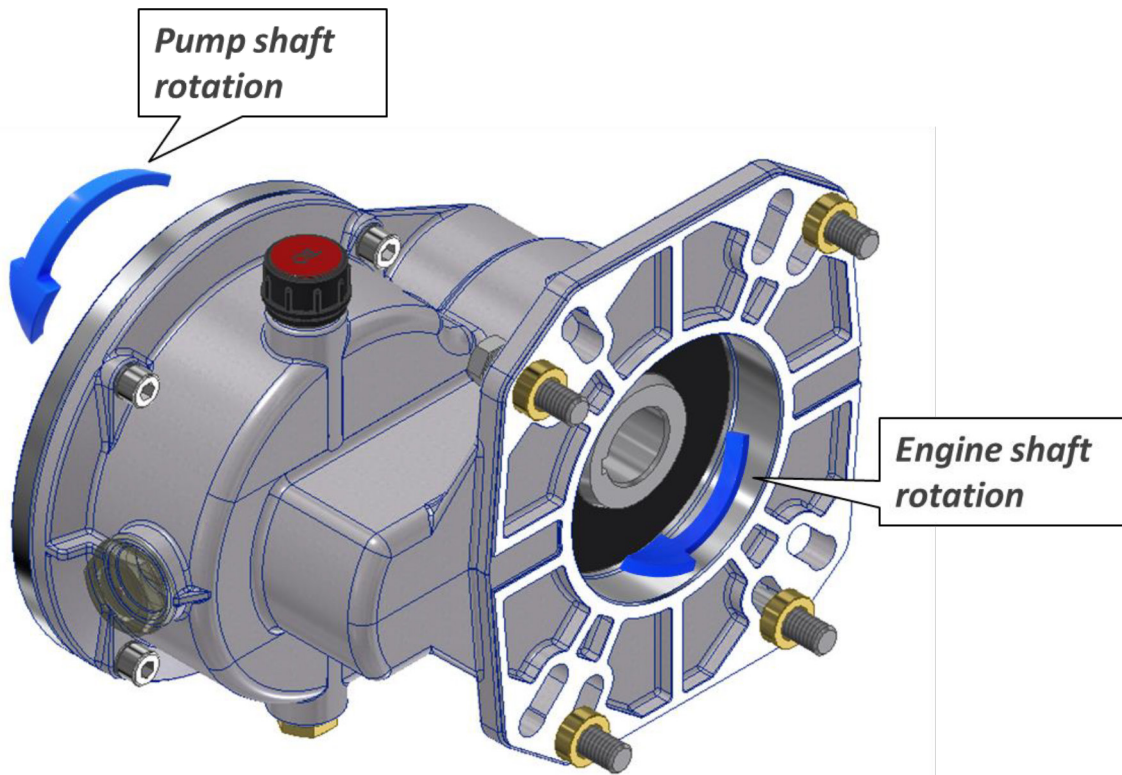

(Fig. 1.3)

The gearbox can be mounted on the pump in both of the ways shown in Fig. 1.4. Just make sure that the vented plug is on the top of the gearbox and the discharge plug on the bottom.

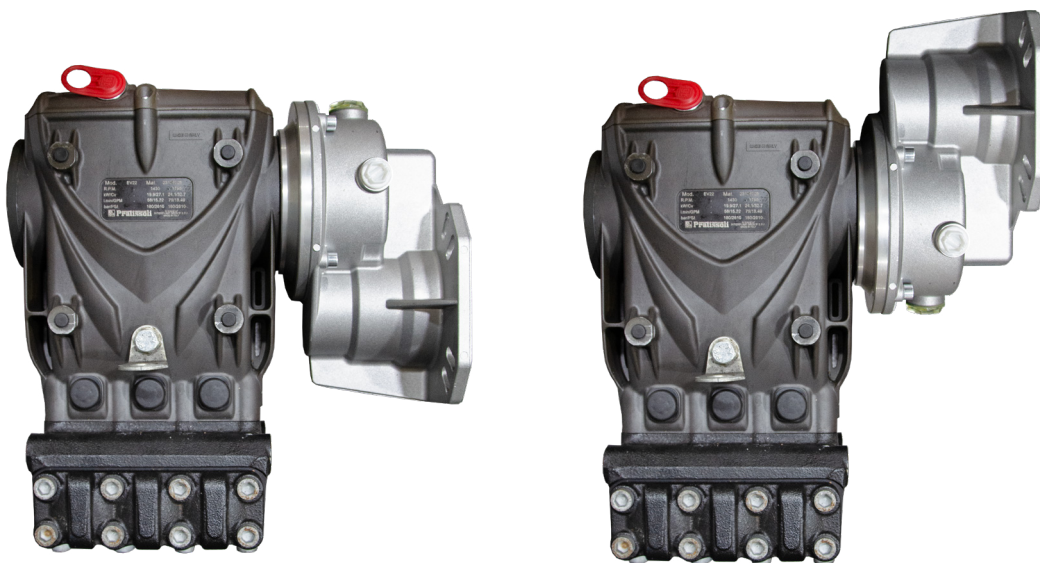

(Fig. 1.4)

YGR1125P40

Gear Reducer

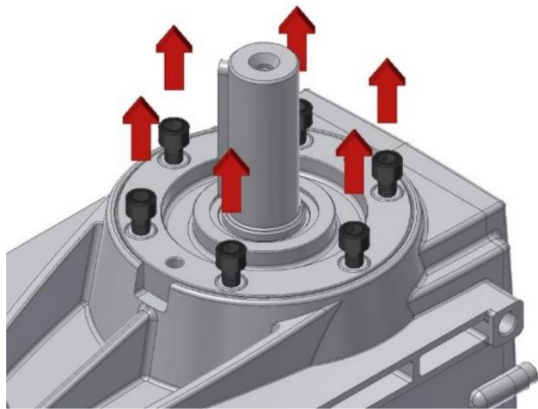

2.1 Having the pump shaft in vertical position remove the bolts which keep the bearing cover to the pump housing. Leave the bearing cover in its position.

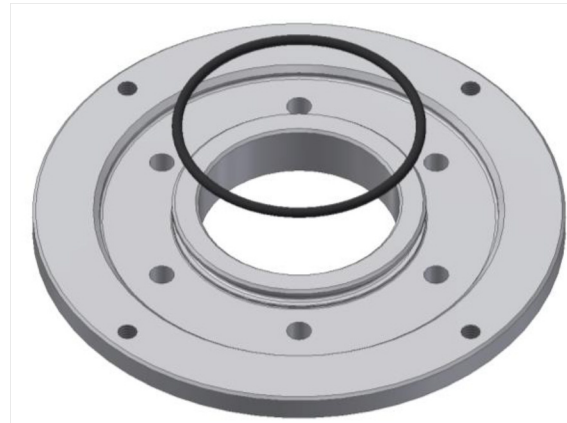

2.2 Set the O-ring Y10321012 in its groove.

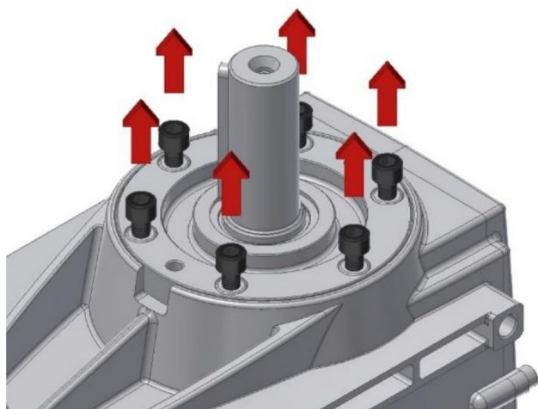

2.3 Attach the flange Y50041241 with the bolts F16195831 and seal washers Y14409800, setting on the threaded part LOCTITE 242 and tighten to 220 in.lbs. (25Mm) MAX.

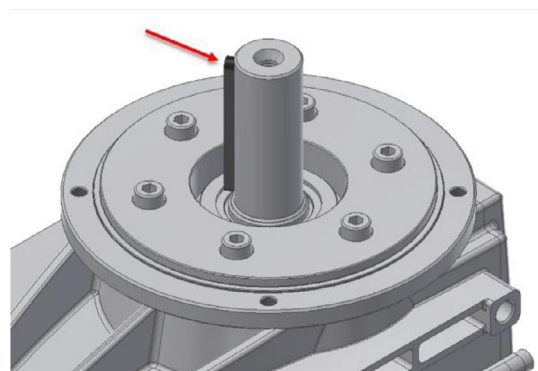

2.4 Be sure that the key is correctly set on the pump shaft.

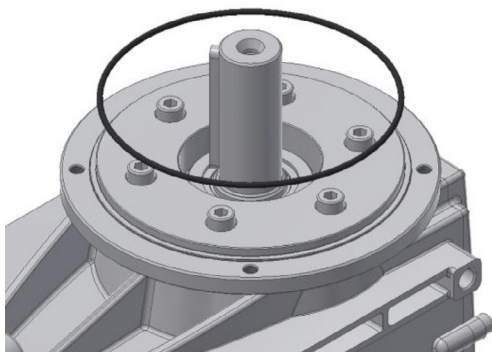

2.5 Insert the O-ring Y10322000 on the flange previously fixed to the pump.



2.4 Assemble the gear Y50041665 on the pump shaft pushing it on the dedicated shoulder and clamp it with the screw Y16223200 with a torque of 440 in.lbs. (50Nm) MAX (use LOCTITE 242).

YGR1125P40

Gear Reducer

GENERAL PUMP *A member of the Interpump Group*

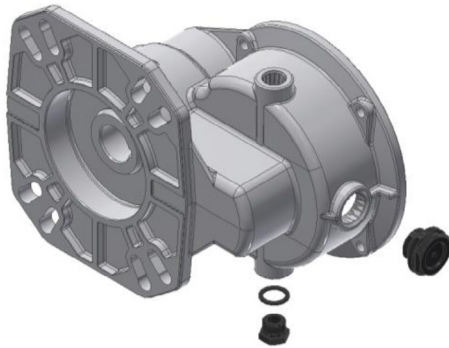

2.7 Complete the assembly of the body (pre-assembled gearbox with pinion, bearings and oil seal) with the oil level sight glass Y15373400 and the discharge plug Y60002831 with corresponding gasket Y14404200.

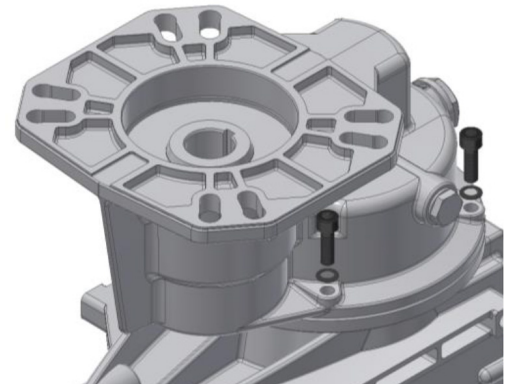

2.8 Proceed to the assembly of the body on the pump flange using the bolts Y16195826 and associated elastic washers with a torque of **220 in.lbs (25 Nm) MAX.**

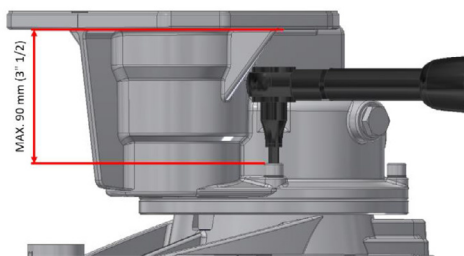

2.9 To use a torque wrench with a max. height of 3.5" (90 mm).



2.10 Hexagonal bit socket with spherical head is recommended.

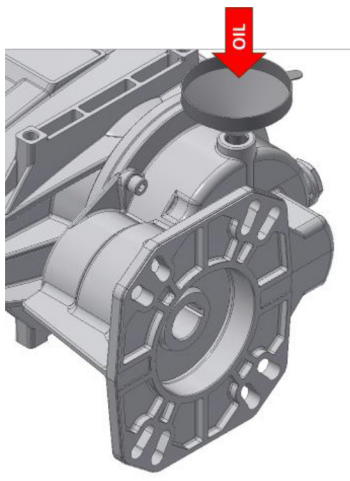

2.11 Fill of the gearbox with oil (gearbox/differential type, **SAE 90**).

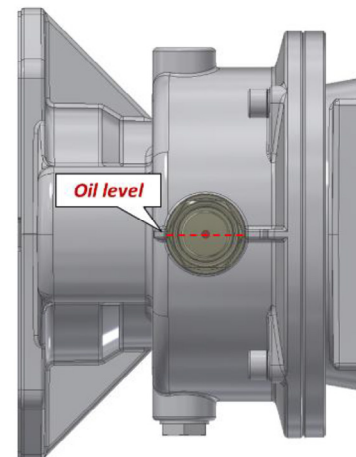

2.12 The oil has to reach the center of the oil level sight glass. The volume needed is around 17 fl. oz. (0.5 L).

YGR1125P40

Gear Reducer

GENERAL PUMP A member of the Interpump Group

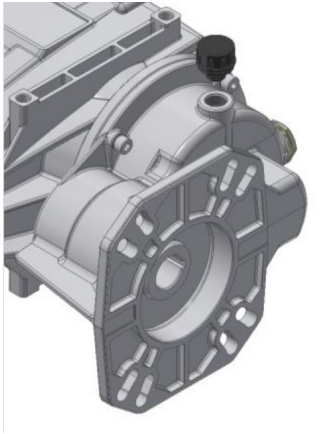

2.13 Close the top hole with the vented plug Y15372600. In case the gearbox-pump unit is not immediately coupled to the engine, and needs to be transported, it is recommended to use temporarily the plug Y15372500 and gasket, which are supplied for this purpose.

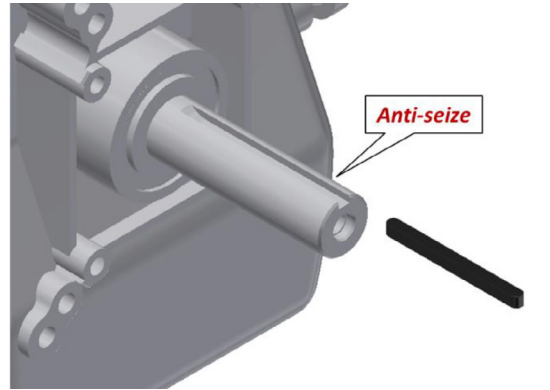

2.14 Check that the key of the engine shaft is correctly set on the keyway. Apply on the same shaft a good anti-seize lubricant (e.g. LOCTITE 8150) to facilitate the possible disassembly.

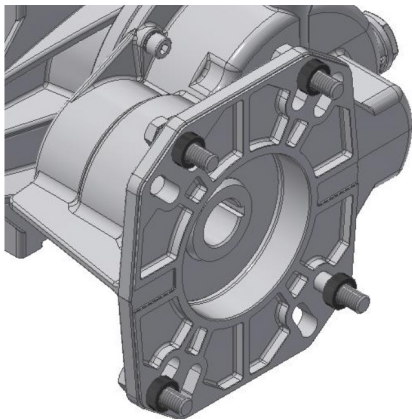

2.15 During coupling with the engine, be sure to fit the 4 spacer rings Y50041731.

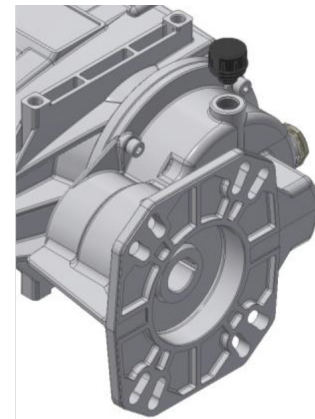

2.16 At this stage be sure that the weight of the pump is already supported. Proceed to the coupling of the gearbox to the engine using the bolts Y16205500 with a torque of **575 lbs. (65 Nm) MAX.**

WARNINGS

WARNING: High Pressure Systems require a primary pressure regulating device (i.e. regulator, unloader) and a secondary pressure relief device (i.e. pop-off valve, relief valve). Failure to install such relief devices properly could result in personal injury or damage to pump or property. GP does not assume any liability or responsibility for the operation of the user's high pressure system.



WARNING: This product can expose you to chemicals including lead, which is known to the state of California to cause cancer and birth defects or other reproductive harm. For more information, go to www.P65Warnings.ca.gov