

Nozzle Holders

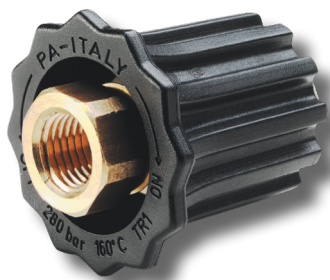

SPECIFICATIONS

ADJUSTABLE NOZZLE HOLDER

Part Number	YADJNOZ
Max. Volume	8.0 GPM
Max. Pressure	4,050 PSI
Max. Temp	320° F
Port Sizes	1/4-18 NPT-F
Weight	4.3 oz

PARTS LIST for YADJNOZ

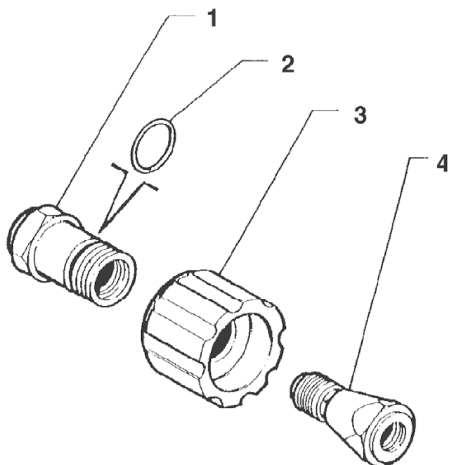

No.	Part No.	Description	Qty.
1	Y22000731	Inlet	1
2	Y10306600	O-ring, .614 x .070	1
3	Y22000622	Knob	1
4	Y22000131	Holder, Nozzle	1

ZUDBL



SPECIFICATIONS

DOUBLE NOZZLE HOLDER

Part Number	ZUDBL
Max. Volume	5.5 GPM
Max. Pressure	3,000 PSI
Port Sizes	1/4-19 BSPP-F
Weight	7.1 oz



General Pump
is a member of
the Interpump Group

