



FEATURES

- Designed for quick and efficient cleaning of interior surfaces of tanks and barrels.
- Small spray turret fits through most barrel and tank access ports.
- Complete orbital coverage of all interior surfaces.
- Rotating speed independent from supply water temperature, pressure or flow.
- Stainless Steel construction with built-in inlet filter for trouble-free operation.

Note: Nozzles not included

Suitable for use in the food industry.

SPECIFICATIONS

Model Number	Y25479000	Y25479100
Rated Pressure	2000 PSI	
Flow Rate	5.3 - 21.0 GPM	
Maximum Fluid Temperature	195° F	
Main Axis Rotating Speed	8 - 13 RPM	
Inlet Port	3/8" BSP	
Nozzle Port Size (2)	1/4" NPT	
Pneumatic Motor: Air Pressure	40 PSI	N/A
Torque	77 Ft.lbs (105 Nm)	
Air Consumption	3.8 l/sec	
Minimum Tank Opening	3.4"	
Weight	11.5 lbs. (with air motor)	
Dimensions	23.2" x 50.8"	

LOSS OF PRESSURE IN RELATION TO FLOW

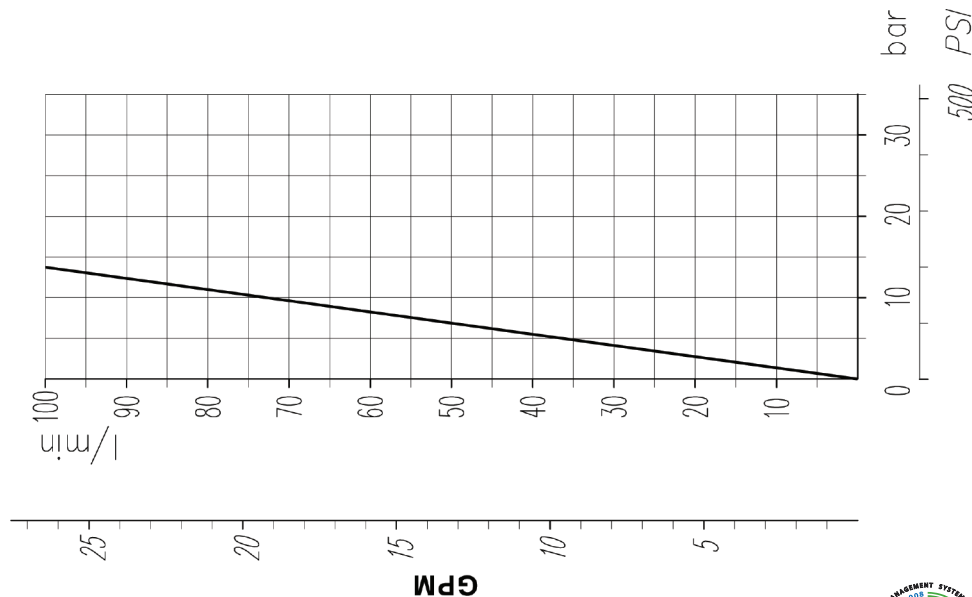

M85P

Pneumatic Tank Cleaning Assemblies

DIMENSIONS

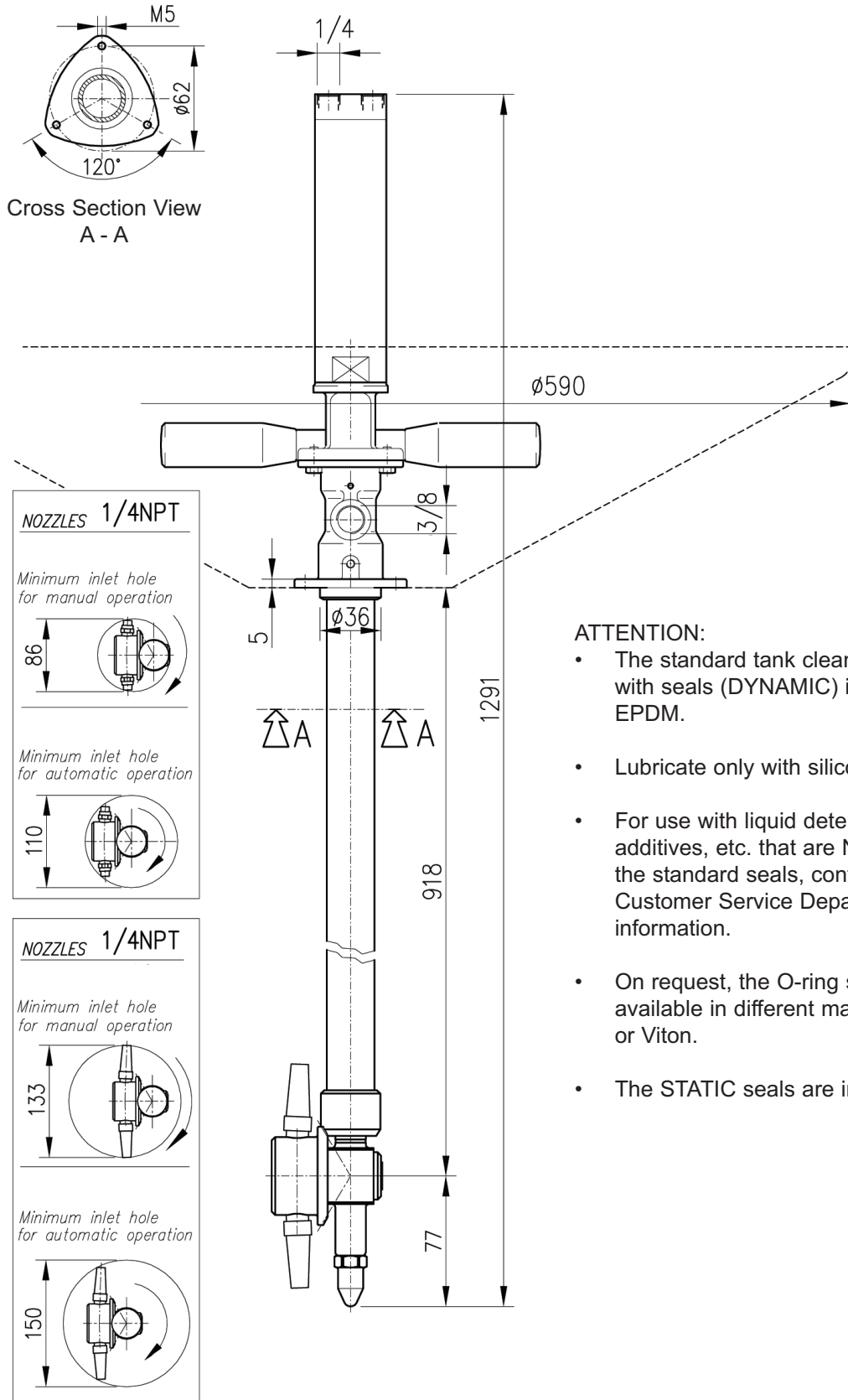

Pneumatic Tank Cleaning Assemblies

INSTRUCTIONS

ATTENTION

The tank cleaning head is placed in rotation by a pneumatic gear motor set positioned on the upper point that gives a high torque on exit. Avoid possible jamming of the rotation from excess material.

UTILIZATION

This cleaning head is designed to be used with water up to 194°F, mixed with detergents or disinfectants of general use. Before using specific liquids (high velocity, very aggressive chemicals, etc.) consult our Customer Service Department. Make sure this equipment is always used with the limits (pressure, temperature, voltage) as specified in this manual.

INSTALLATION

In order to avoid bodily injuries and damages to property, the cleaning head must always be connected to a pressure circuit, normally fed by a plunger pump, pressure washer or similar equipment, provided with all necessary safety and control features (safety valve, pressure regulator, etc.) required by law. For the connection make sure that a flexible hose with correct capacity and resistance is used, avoiding sharp bends and variation of flow direction in order to reduce pressure drop. The head must be firmly secured to the tank opening or a suitable support.

CHOICE OF NOZZLES

The solid stream spray nozzles for high pressure washing must be adequate to operating flow rate and pressure, bearing in mind that the pressure value to be taken into consideration while choosing, is the one obtained subtracting from the pump pressure the loss of pressure determined by the delivery line and the head itself. This latest value can be obtained from the diagram on page 1.

OPERATION

The head is driven by a pneumatic motor set in the upper part. A complete washing cycle is carried out after 57 revolutions of the main axis, considering that a complete washing cycle is over once the jets have covered an ideal sphere and have returned to the starting point. As the head speed ranges between 8 and 13 RPM, a complete cycle is carried out in approximately 4.5 to 7 minutes. For a perfect cleaning we recommend at least 3 complete cycles.

FILTRATION

The fluid sent from the system to the cleaning head has to be filtered in order to prevent the entrance of any foreign matter due to bad functioning, which leads to frequent maintenance. The degree of filtration recommended is at least 300 micron.

SERVICING

After a normal daily usage, wash the internal part of the head only with water minus any additives.

After 100 hours of use, check the conditions of the internal parts (gears, bearings, dynamic seals).

The incorrect choice of the O-ring material (dynamic seals) can cause an irregular function and a rapid deterioration of these parts. In the presence of dimensional alterations (swelling) of the dynamic seals (O-ring + PTFE), control the compatibility of the O-rings with the liquids used. If they are incompatible, contact our Customer Service Department.

Check the internal parts every 300 to 400 hours of use in order to verify any premature wear, especially the dynamic seals (items 3 and 20) As a precaution, inspect the surface for wear or damage. **Replace if worn or damaged.**

Check also the condition of the bearings, bushings and gears. **Replace if damaged.**

Use only original General Pump spare parts.

If exposed to freezing temperatures, make sure that the head is completely emptied after use in order to prevent freeze up. Lubricate with silicone grease only. **DO NOT USE MINERAL GREASE OR OIL, OTHERWISE RUPTURE OF THE INTERNAL PARTS MAY OCCUR.**

SAFETY INFORMATION

- **Improper use of high pressure jets can be very dangerous.**
- **Never point the jets towards people, animals or electrical appliances.**
- **Make sure that the pumping system is equipped with suitable safety devices.**
- **Original General Pump parts only must be used for repair and servicing.**
- **High pressure hoses and connections are very important to the general safety of the equipment. Be sure to use only components correctly sized and guaranteed by the manufacturer.**

M85P

Pneumatic Tank Cleaning Assemblies

Y25479000 PARTS LIST

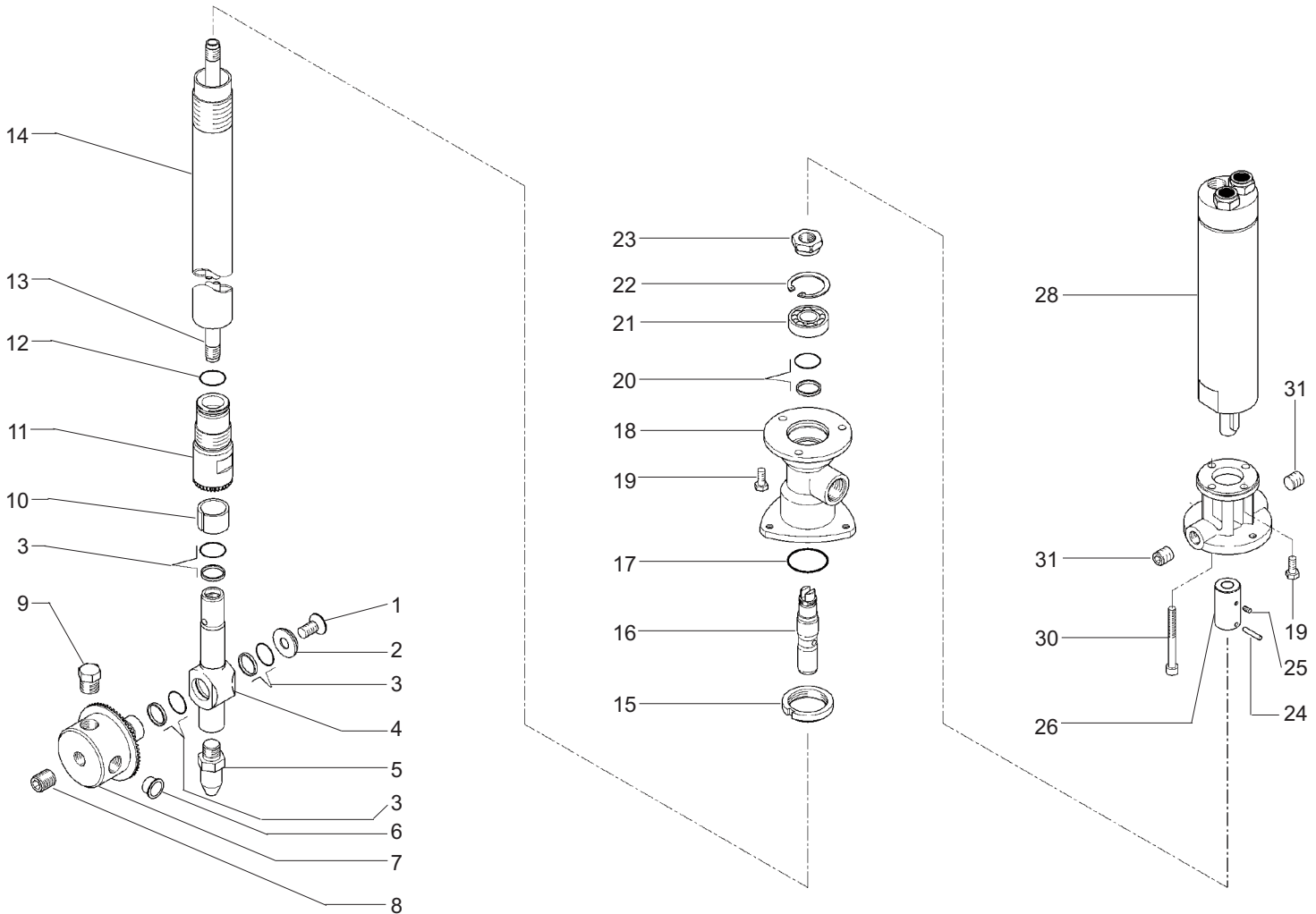

Item	Part #	Description	Qty.
1	Y16195412	Screw, M8x12mm, SST	1
2	Y80009451	C/sunk Washer, 8.5x28x4.5mm, SST	1
3*	Y10203018	Stem Seal, 18x23x2mm + O-ring, EPDM	3
4	Y80009351	Buffer, M12, SST	1
5	Y80000451	Buffer Tip, M12, SST	1
6	Y15372014	Plug, 1/4" BSP	2
7	Y80009151	Nozzle Holder Pinion, 4x1/4 NPT-F, SST	1
8	Y16224212	Set Screw, M12x12mm, SST	1
9	Y15372114	Grub Screw, 1/4 NPT-M, SST	2
10**	Y80002485	Bushing, Open, 18x22x14.8, PTFE	1
11	Y80009251	Pinion, SST	1
12*	Y10318410	O-ring, 2.62x18.72mm	1
13	Y80009556	Tube, M10x1mm	1
14	Y80005256	Tube, M28x1mm	1
15	Y80001251	Ring Nut, M28x1, SST	1
16	Y80009851	Propeller Shaft, SST	1

Item	Part #	Description	Qty.
17*	Y10320510	O-ring, 2.62x26.64 mm	1
18	Y80005152	Manifold, 3/8 BSP-F, SST	1
19	Y16187002	Screw, M5x12mm, SST	6
20*	Y10203000	Stem Seal, 15x20x2.2mm, + O-ring	1
21**	Y11441228	Ball Bearing, 12x28x8mm	1
22**	Y10101105	Snap Ring, SST	1
23**	Y80009751	Nut	1
24	Y15103000	Roll Pin, 3x16mm, SST	1
25	Y16210110	Set Screw, M4x5 mm, SST	1
26	Y80003751	Joint, 11x37 mm, SST	1
28	Y13080000	Pneumatic Gear Motor	1
29	Y80003642	Flange for Air-Driven Motor	1
30	Y16211500	Screw, M5x50mm, SST	1
31	Y16223205	Set Screw	2
*	Y25472124	M85P SEAL KIT	
**	Y25472424	BALL BEARING KIT	

M85P

Pneumatic Tank Cleaning Assemblies

GENERAL PUMP *A member of the Interpump Group*

Y25479100 PARTS LIST

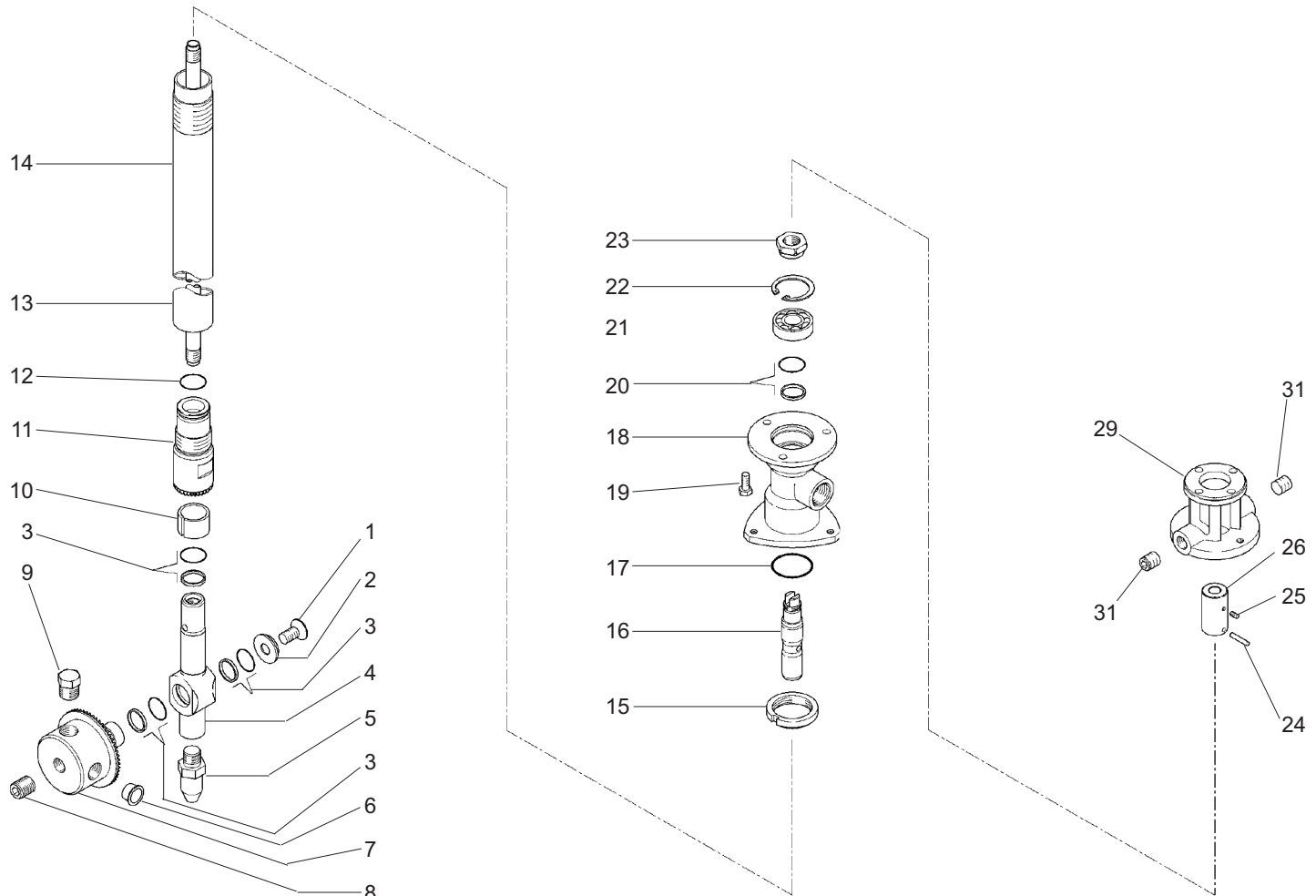

Item	Part #	Description	Qty.
1	Y16195412	Screw, M8x12mm, SST	1
2	Y80009451	C/sunk Washer, 8.5x28x4.5mm, SST	1
3*	Y10203018	Stem Seal, 18x23x2mm + O-ring, EPDM	3
4	Y80009351	Buffer, M12, SST	1
5	Y80000451	Buffer Tip, M12, SST	1
6	Y15372014	Plug, 1/4" BSP	2
7	Y80009151	Nozzle Holder Pinion, 4x1/4 NPT-F, SST	1
8	Y16224212	Set Screw, M12x12mm, SST	1
9	Y15372114	Grub Screw, 1/4 NPT-M, SST	2
10**	Y80002485	Bushing, Open, 18x22x14.8, PTFE	1
11	Y80009251	Pinion, SST	1
12*	Y10318410	O-ring, 2.62x18.72mm	1
13	Y80009556	Tube, M10x1mm	1
14	Y80005256	Tube, M28x1mm	1
15	Y80001251	Ring Nut, M28x1, SST	1
16	Y80009851	Propeller Shaft, SST	1

Item	Part #	Description	Qty.
17*	Y10320510	O-ring, 2.62x26.64 mm	1
18	Y80005152	Manifold, 3/8 BSP-F, SST	1
19	Y16187002	Screw, M5x12mm, SST	6
20*	Y10203000	Stem Seal, 15x20x2.2mm, + O-ring	1
21**	Y11441228	Ball Bearing, 12x28x8mm	1
22**	Y10101105	Snap Ring, SST	1
23**	Y80009751	Nut	1
24	Y15103000	Roll Pin, 3x16mm, SST	1
25	Y16210110	Set Screw, M4x5 mm, SST	1
26	Y80003751	Joint, 11x37 mm, SST	1
29	Y80003642	Flange for Air-Driven Motor	1
31	Y16223205	Set Screw	2
*	Y25472124	M85P SEAL KIT	
**	Y25472424	BALL BEARING KIT	