

NEEDLE VALVE

In-line Adjustable Needle Valve

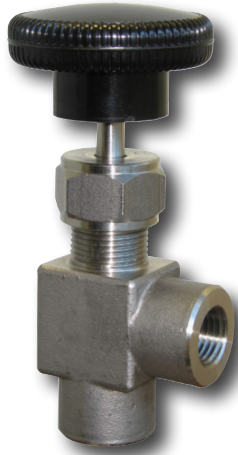

SPECIFICATIONS

Part Number	WMNV14SS
Maximum Flow	5.0 GPM
Maximum Pressure	5,000 PSI
Maximum Temperature	150° F
Ports Sizes: Inlet	1/4" NPT-F
Outlet	1/4" NPT-F
Dimensions	2.0" x 2.0" x 3.5"
Weight	0.6 lb.
Materials	316 Stainless Steel, Teflon

PARTS LIST

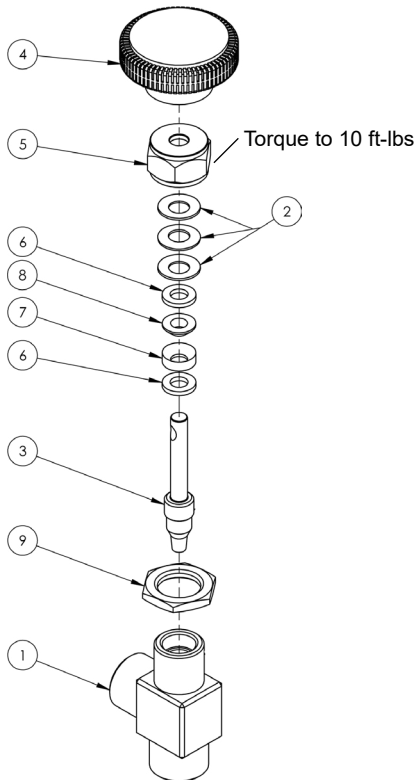

FEATURES

- Adjustable from full flow to full close
- Durable, comfortable handle
- Can be panel mounted in any position
- Made in the USA

DIMENSIONS

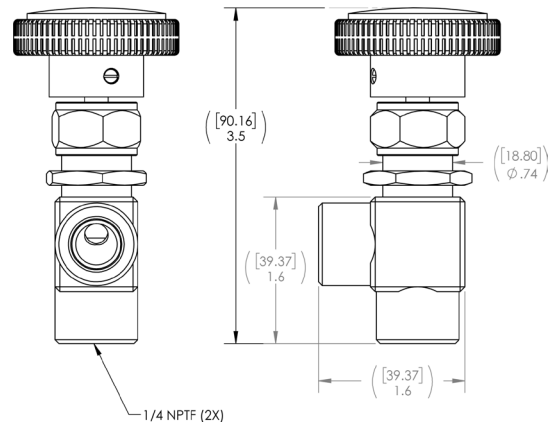

ORIENTATION OF PACKING SPRINGS

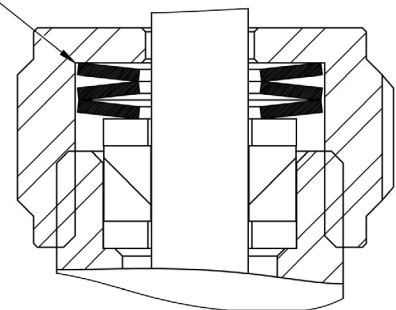

No.	Part No.	Description	Qty.
1	520402	Body	1
2	720072	Packing Spring	3
3	520400	Stem	1
4	660255	Knob	1
5	520399	Packing Nut	1
6	200073	Gland	2
7	660256	Upper Packing	1
8	660257	Lower Packing	1
9	520401	Panel Nut	1



General Pump is a member of the Interpump Group

