

TX Series "63"

Triplex Plunger Pump, Solid Shaft

FEATURES

- Flex coupling and bell housing available for direct drive
- Oversized bearings for long life
- New generation seal system for longer life
- Forged brass manifold

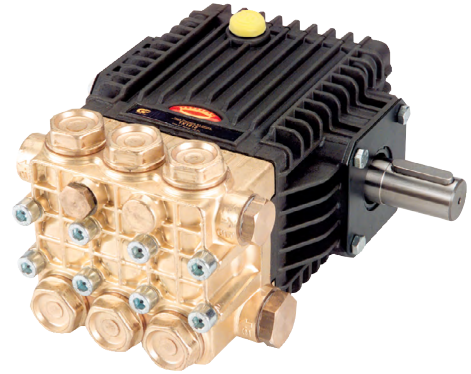

SPECIFICATIONS

Pump Model	TX1810S17	TX1812S17	TX1512S17	TX1506S34	TX1508S34	TX1510S34
Maximum Volume	3.2 GPM	3.8 GPM	2.6 GPM	2.6 GPM	3.0 GPM	4.0 GPM
Maximum Discharge Pressure	2500 PSI			3000 PSI		
Horsepower	4.2 EBHP	5.2 EBHP	5.3 EBHP	5.3 EBHP	6.2 EBHP	8.2 EBHP
Maximum Pump Speed	1750 RPM			3400 RPM		
Maximum Inlet Pressure	125 PSI					
Minimum Inlet Pressure	3 Ft. Water / 2.6 in. Hg.			Flooded		
Plunger Bore (in / mm)	.709 in / 18 mm			.591 in / 15 mm		
Plunger Stroke (in / mm)	.394 in / 10 mm	.472 in / 12 mm		.256 in./6.5 mm	.315 in / 8 mm	.394 in / 10mm
Oil Capacity	14.0 oz					
Maximum Fluid Temperature	165°F					
Inlet Port Thread	1/2 - 14 BSPP-F					
Discharge Port Thread	3/8 - 19 BSPP-F					
Shaft Diameter	.945 in / 24 mm					
Weight	19 lbs					
Dimensions	8.4 x 8.3 x 4.8 in					

DIMENSIONAL DRAWING

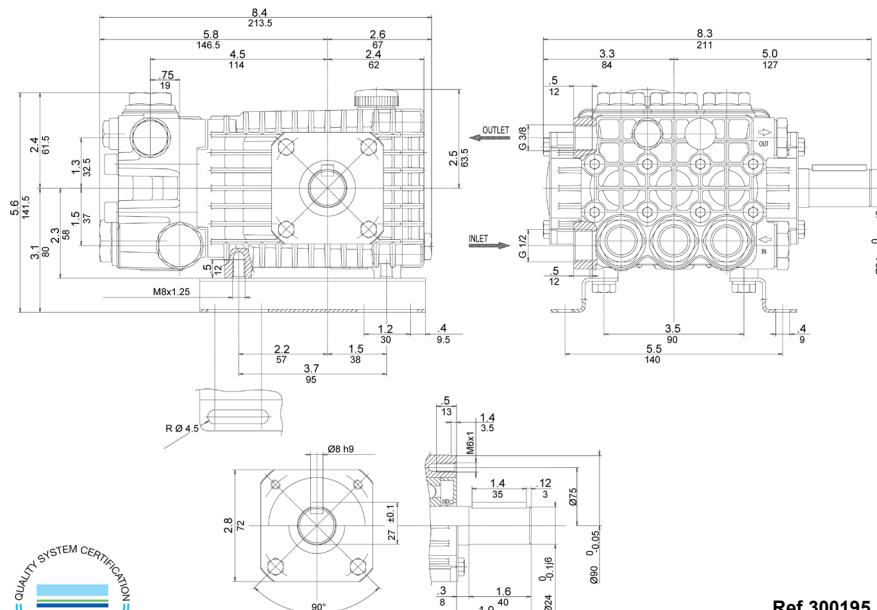

General Pump
is a member of
the Interpump Group



Ref 300195 Rev. J
07-22



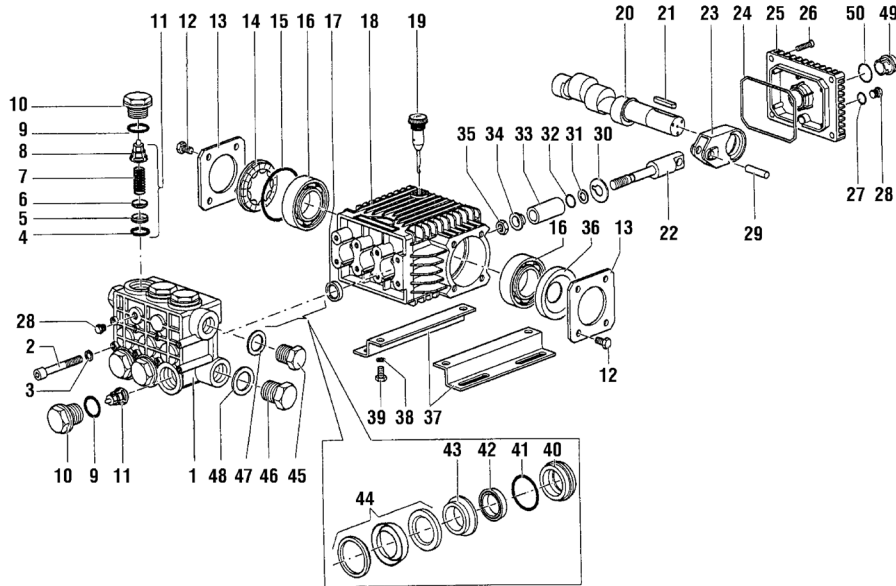

PARTS LIST

ITEM	PART NO.	DESCRIPTION	QTY.	ITEM	PART NO.	DESCRIPTION	KIT NO.	QTY.	ITEM	PART NO.	DESCRIPTION	KIT NO.	QTY.
1.	63120041	Manifold, 15 mm	1	20.	63021265	Crankshaft, 10 mm	1	36.	90164100	Oil Seal	1		
	63120341	Manifold, 18 mm	1		63021665	Crankshaft, 12mm	1	37.	50200074	Rail	2		
2.	99319200	Screw, M8 x 65	8	21.	91489200	Key	1	38.	96701600	Lockwasher, M8	4		
3.	96701400	Lockwasher, M8.4	8	22.	63050066	Plunger Guide	3	39.	99303700	Screw, M8 x 16	4		
4.	90384100	O-ring	6	23.	63030022	Connecting Rod	3	40.	63080070	Seal Retn'r, 15mm	162,166	3	
5.	36200366	Valve Seat	6	24.	90392000	O-ring, Cover	1		63080170	Seal Retn'r, 18mm	163,167	3	
6.	36200176	Valve Plate	6	25.	63160022	Rear Crankcase Cover	1	41.	90360800	O-ring	166,167	3	
7.	94737600	Spring	6	26.	99183700	Screw, M6 x 14	4	42.	90260800	Seal, LP,15mm	160,166	3	
8.	36202551	Valve Cage	6	27.	701013	O-ring	1		90265000	Seal, LP,18mm	161,167	3	
9.	90384700	O-ring	6	28.	98204100	Plug, 1/4" G	2	43.	63216070	Int. Ring,15mm	164,166	3	
10.	98222600	Valve Cap	6	29.	97733500	Connecting Rod Pin	3		63216170	Int. Ring,18mm	165,167	3	
11.	36711501	Valve Assembly	6	30.	96707500	Flinger Washer	3	44.	90261200	Packing Assy,15mm	160,166	3	
12.	99180700	Screw, M6 x 10	8	31.	660024	Anti-extrusion Ring	3		90265400	Packing Assy,18mm	161,167	3	
13.	50150074	Bearing Cover	2	32.	701009	O-ring	3	45.	98210000	Plug, 3/8" G	1		
14.	44211801	Oil Level Indicator	1	33.	52040009	Ceramic Plunger, 15mm	3	46.	98217600	Plug, 1/2" G	1		
15.	90409700	O-ring	1		44040109	Ceramic Plunger, 18mm	3	47.	96738000	Washer, M17.5	1		
16.	91832900	Ball Bearing	2	34.	44211570	Bushing	3	48.	96751400	Washer, M21.5	1		
17.	90159500	Oil Seal	3	35.	92221600	Nut, M8	3	49.	63210051	Oil Level Indicator	1		
18.	63010022	Crankcase	1					50.	90405100	O-ring	1		
19.	98210300	Oil Dip Stick	1										

REPAIR KITS

KIT NO.	K123	K124	K159	K160 or K161	K162 or K163	K164 or K165	K166 or K167
ITEM NO's INCLUDED IN KIT	4, 5, 6, 7, 8 (11)	9, 10	17	42, 44	40	43	40, 41, 42, 43, 44
NUMBER OF ASSEMBLIES IN KIT	6	6	3	3	3	3	1
NUMBER OF CYLINDERS KIT WILL SERVICE	3	3	3	3	3	3	1

TORQUE SPECS*

Pos.	Ft/lb	Nm
2	14.7	20
10	95.9	130
12	7.3	10
26	7.3	10
28	14.7	20
35	11.0	15
39	14.7	20
45	29.4	40
46	29.4	40

* Decrease torque by 20% if threads are lubricated

WARNING: High Pressure Systems require a primary pressure regulating device (i.e. regulator, unloader) and a secondary pressure relief device (i.e. pop-off valve, relief valve). Failure to install such relief devices properly could result in personal injury or damage to pump or property. GP does not assume any liability or responsibility for the operation of the user's high pressure system.



WARNING: This product can expose you to chemicals including lead, which is known to the state of California to cause cancer and birth defects or other reproductive harm. For more information, go to www.P65Warnings.ca.gov