

### FEATURES

- 316 Stainless Steel manifold for maximum corrosion resistance
- Stainless Steel inlet and outlet valves
- Solid ceramic plungers
- Ball bearings on both sides
- Low- and high-pressure HT seals

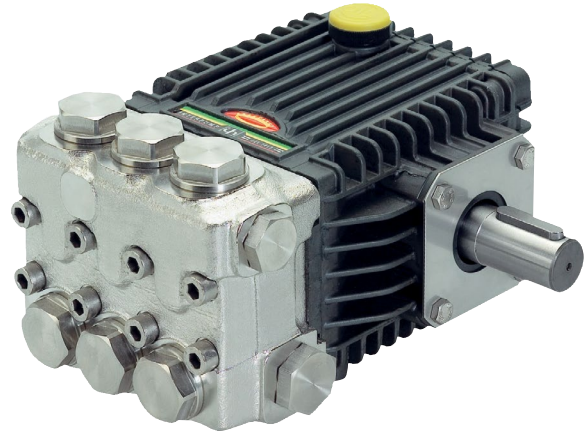

### SPECIFICATIONS

Pump Model	TX1510S17SS	TX1512S17SS	TX1810S17SS	TX1812S17SS
Maximum Volume	2.1 GPM	2.6 GPM	3.1 GPM	3.8 GPM
Maximum Discharge Pressure	2200 PSI		2000 PSI	
Horsepower	4.3 EBHP	5.3 EBHP	4.2 EBHP	5.2 EBHP
Maximum Pump Speed	1750 RPM			
Maximum Inlet Pressure	125 PSI			
Maximum Inlet Vacuum	3 ft. water (2.6 in. Hg)			
Plunger Bore	.591 in./15 mm		.709 in./18 mm	
Plunger Stroke	.394 in./10 mm	.472 in./12mm	.394 in./10 mm	.472 in./12mm
Crankcase Oil Capacity	14.0 oz.			
Maximum Fluid Temperature	185° F			
Inlet Port Thread	1/2"-14 BSP-F			
Discharge Port Thread	3/8"-19 BSP-F			
Shaft Diameter	.945 in./24 mm			
Weight	22.3 lbs.			
Dimensions	8.4" x 8.3" x 4.8"			

### DIMENSIONAL DRAWING

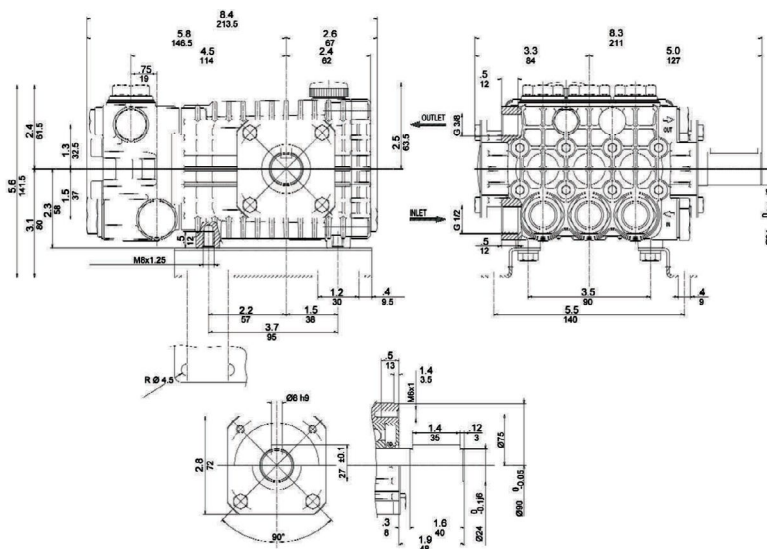

TRIPLEX

TRIPLEX



General Pump is a member of the Interpump Group



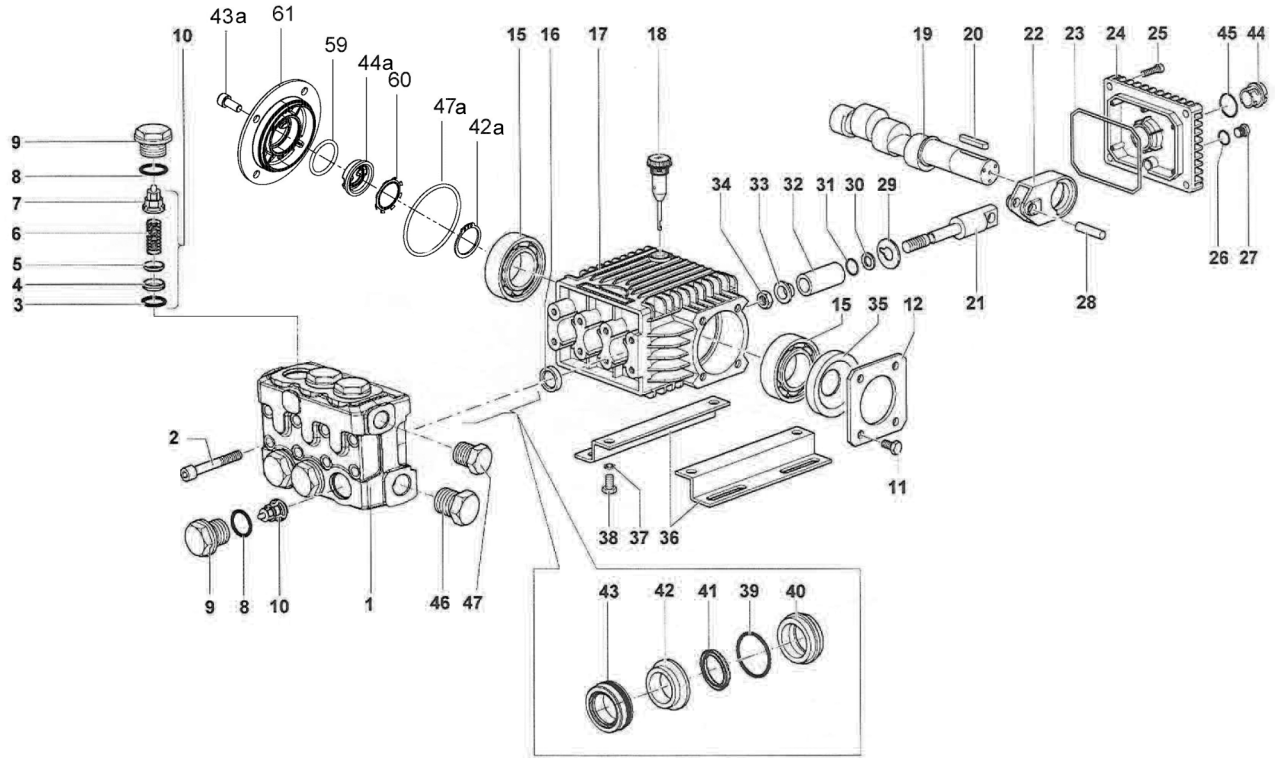

**PARTS LIST**

ITEM	PART NO.	DESCRIPTION	QTY.	ITEM	PART NO.	DESCRIPTION	QTY.	ITEM	PART NO.	DESCRIPTION	QTY.
1.	63121636	Manifold, 15 mm	1	22.	63030022	Connecting Rod	3	40.	63080666	Seal Retainer, 15 mm, SS	3
	63121936	Manifold, 18 mm	1	23.	90392000	O-ring, Cover	1		63080766	Seal Retainer, 18 mm, SS	3
2.	99319300	Screw, M8 x 65	8	24.	63160022	Rear Crankcase Cover	1	41.	90215000	Seal, 15 mm, L.P.	3
3.	701115	O-ring, Ø 17.13 x 2.62	6	25.	99183800	Screw, M6 x 14	4		90220000	Seal, 18 mm, L.P.	3
4.	36203666	Valve Seat, SS	6	26.	701013	O-ring, Ø 10.82 x 1.78	1	42.	63216466	Intermediate Ring, 15 mm	3
5.	36711501	Valve Plate	6	27.	98204000	Plug, G1/4 x 9	1		63216566	Intermediate Ring, 18 mm	3
6.	94737300	Spring, SS	6	28.	97733500	Connecting Rod Pin	3	42a.	90063500	Stop Ring Ø 25	1
7.	36202551	Valve Cage	6	29.	96707600	Flinger Washer	3	43.	90216000	Seal, 15 mm, H.P.	3
8.	701002	O-ring	6	30.	660024	Anti-extrusion Ring	3		90221000	Seal, 18 mm, H.P.	3
9.	98222900	Valve Cap	6	31.	90357300	O-ring, Ø 5.28 x 1.78	3	43a.	99183700	Screw M6x14	8
10.	36713001	Valve Assembly, SS	6	32.	52040009	Plunger, 15 mm	3	44.	63210051	Oil Level Indicator	1
15.	91833100	Ball Bearing	2		44040109	Plunger, 18 mm	3	44a.	53210851	Oil Level Indicator	1
16.	90159500	Oil Seal, Ø 18 x 26 x 6	1	33.	63211566	Bushing	3	45.	90405100	O-ring, Ø 26.58 x 3.53	1
17.	63010022	Crankcase	3	34.	92221500	Nut, M8	3	46.	98218000	Plug, 1/2" G	1
18.	98210300	Oil Dip Stick	1	35.	90164100	Oil Seal	1	47.	98210066	Plug, 3/8" G	1
19.	63021265	Crankshaft, 10 mm	1	36.	50200074	Rail	2	47a.	90389800	O-ring Ø 56.82x2.62	1
	63021665	Crankshaft, 12 mm	1	37.	96701600	Lockwasher, M8	4	59.	90385900	O-ring Ø 25.07x2.62	1
20.	91489200	Key	1	38.	99903700	Screw, M8 x 16	4	60.	90067100	Stop Ring	1
21.	63050166	Plunger Guide	3	39.	90360800	O-ring, Ø 28.30 x 1.78	3	61.	58150122	Side Cover	1

\* 53150001 Oil Level Indicator Assembled W/O Screws and O-ring

**REPAIR KITS**

KIT NO.	159	192	214 or 204 (15 mm) (18 mm)	215 or 216 (15 mm) (18 mm)
ITEM NO's INCLUDED IN KIT	16	3, 4, 5, 6, 7 (10)	41, 43	39, 40, 41, 42, 43
NUMBER OF ASSEMBLIES IN KIT	3	6	3	1

**TORQUE SPECS\***

Pos.	Ft/lb	N-M
2	14.7	20
9	95.9	130
11	7.3	10
25	7.3	10
27	14.7	20
34	11.0	15
38	14.7	2
46	29.4	40
47	29.4	40

\* Decrease torque by 20% if threads are lubricated

