

FEATURES

- Built-in Pressure Trapping Unloader and Injector
- Next Generation Packings for Exceptional Seal Life
- Solid White Ceramic Plungers
- Direct-Drive for Convenience and Durability
- Oversized Connecting Rods

**SPECIFICATIONS**

Pump Model	TX1508G8UI	TX1509G8UI	TX1510G8UI
Maximum Volume	3.0 GPM	3.5 GPM	4.0 GPM
Maximum Pressure	3000 PSI		
Maximum RPM	3400 RPM		
Maximum Inlet Pressure	125 PSI		
Minimum Inlet Pressure	3 ft (2.6 in Hg) Positive Pressure		
Maximum Fluid Temperature	165° F		
Bore (in / mm)	.591 in / 15mm		
Stroke (in / mm)	.315 in / 8 mm	.355 in / 9 mm	.394 in / 10 mm
Oil Capacity	14.0 oz		
Inlet Port Thread	1/2"-14 BSP-F		
Discharge Port Thread	3/8"-19 BSP-F		
Shaft Diameter	1" - Hollow		
Motor Flange	J609-b		
Weight	18.2 lb		
Dimensions - Inches - Nominal	11.3 x 9.5 x 9.1		

PERFORMANCE*

Pump Model	TX1508G8UI	TX1509G8UI	TX1510G8UI
Recommended Nozzle Size	#3.5	#4.0	#4.5
PSI at Recommended Nozzle	3000	3000	3000
PSI at .5 Size Larger	2250	2400	2400
PSI at 1.0 Size Larger	1750	1950	2000
PSI at 1.5 Sizes Larger	1400	1600	1750
PSI at 2.0 Sizes Larger	1150	1350	1500

* Values are theoretical. Actual performance may vary slightly depending on conditions

TX Series 63 UI

Direct Drive Triplex Plunger Pump

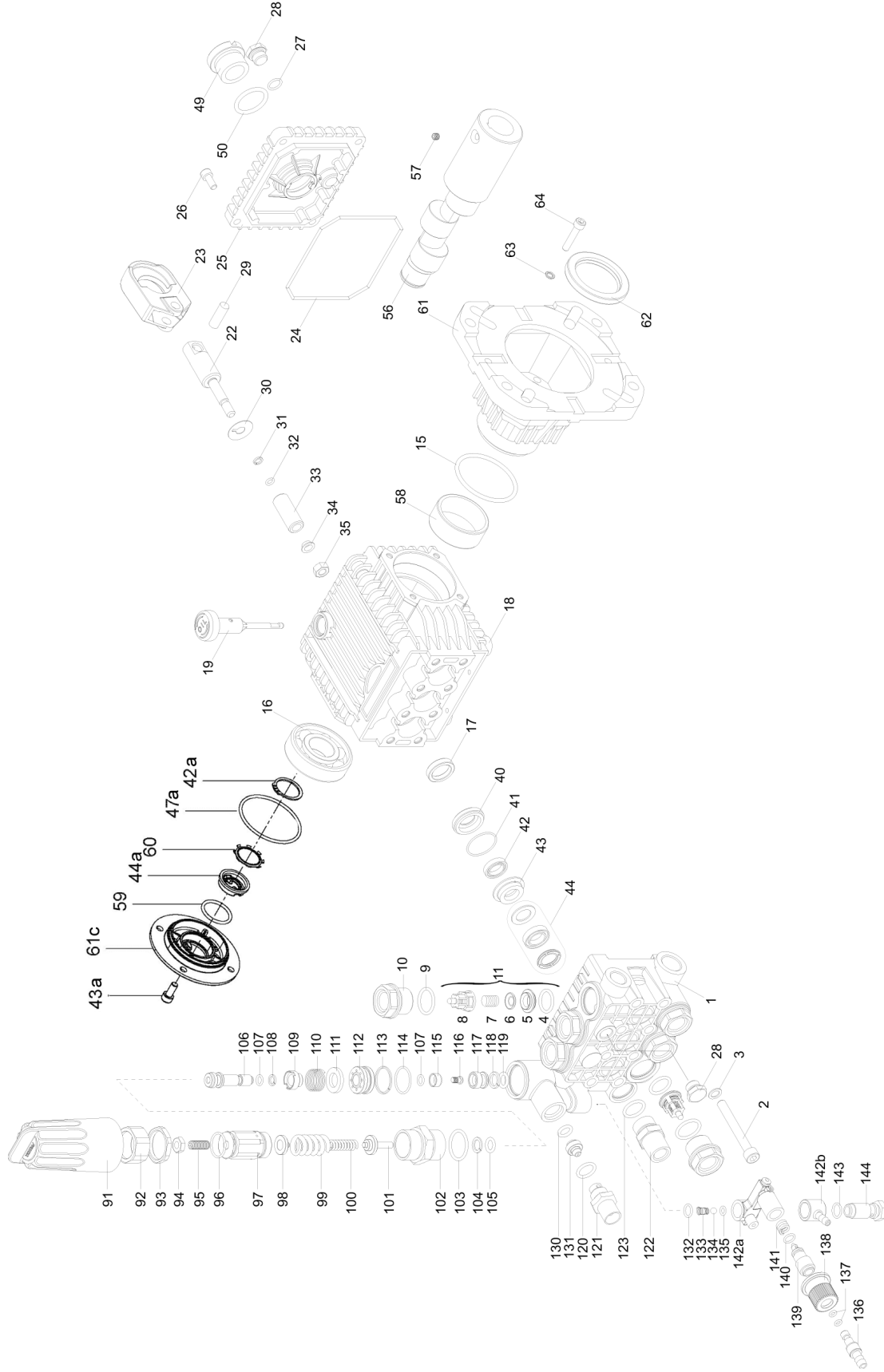

PART LIST

Item	Part no.	Description	Qty	Item	Part no.	Description	Qty	Item	Part no.	Description	Qty
1	63120641	Manifold, 15 mm, RH	1	44a	53210851	Oil Level Indicator	1	105	90382000	O-ring	1
2	99319200	Screw, M8 x 65	8	45	98210000	Plug, 3/8" G	1	106	36323470	Sleeve	1
3	96701400	Lockwasher, M8.4	8	46	98217600	Plug, 1/2" G	1	107	90357500	O-ring	2
4	701115	O-ring	6	47	96738000	Washer, M17.5	1	108	90502500	Anti-Ext ring	1
5	36200366	Valve Seat	6	47a	90389800	O-ring Ø 56.82x2.62	1	109	36323070	Spacer	1
6	36711501	Valve Plate	6	48	96751400	Washer, M21.5	1	110	94748500	Spring	1
7	94737600	Spring	6	49	63210051	Oil Level Indicator	1	111	36323151	Valve	1
8	36202551	Valve Cage	6	50	90405100	O-ring	1	112	36322970	Valve guide	1
9	701002	O-ring	6	56	63026465	Crankshaft, 6.5mm (3/4")	1	113	90360000	O-ring	1
10	98222600	Valve Cap	6		63028065	Crankshaft, 8mm (1")		114	90514400	Anti-Ext ring	1
11	36711501	Valve Assembly	6		63028265	Crankshaft, 9mm (1")		115	36319066	Spherical valve	1
16	91832900	Ball Bearing	1		63028465	Crankshaft, 10mm (1")		116	99150900	Screw	1
17	90159500	Oil Seal	3	57	99179000	Screw, M6 x 6	1	117	36316466	Seat	1
18	63010022	Crankcase	1	58	91856800	Roller bearing	1	118	701614	O-ring	1
19	98210300	Oil Dip Stick	1	59	90385900	O-ring Ø 25.07x2.62	1	119	90506500	Anti-Ext ring	1
22	63050066	Plunger Guide	3	60	90067100	Stop Ring	1	120	90383200	O-ring	1
23	63030022	Connecting Rod	3	61a	10061722	Flange 3/4", gas engine	1	121	10007870	Nipple, Disch - 3/8"G-M	1
24	90392000	O-ring, Cover	1	61b	10051822	Flange 1", gas engine	1		10014770	Nipple, Disch - M22 (opt)	
25	63160022	Rear Crankcase Cover	1	61c	58150122	Side Cover	1	130	701614	O-ring	1
26	99183700	Screw, M6 x 14	4	62	90169000	Oil Seal	1	131	10015166	Nozzle 2.0mm (2.1-3.0)	1
27	701013	O-ring	1	63	203510	Washer	4		10007666	Nozzle 2.2mm (3.1-4.5)	
28	98204100	Plug, 1/4" G	2	64	99191200	Screw, M6 x 30	4	132	701012	O-ring	1
29	97733500	Connecting Rod Pin	3	91	36318751	Handle (Red)	1	133	94821700	Conical spring	1
30	96707500	Flinger Washer	3	92	36318670	Locking sleeve (opt. w/93)	1	134	9478200	Ball	1
31	660024	Anti-extrusion Ring	3	93	92293500	Locking nut (opt. w/92)	1	135	701501	O-ring	1
32	701009	O-ring	3	94	92221800	Nut	1	136	36260870	Hose barb	1
33	52040009	Ceramic Plunger, 15mm	3	95	99305400	Set screw	1	137	701008	O-ring	2
34	44211570	Bushing	3	96	701019	O-ring	1	138	36256551	Knob	1
35	92221600	Nut, M8	3	97	36318570	Regulator knob	1	139	36256470	Shutter	1
40	63080070	Seal Retn'r, 15mm	3	98	36316970	Spring seat	1	140	701612	O-ring	1
41	90360800	O-ring	3	99	94743600	Spring (3000 PSI)	1	141	94738300	Spring	1
42	90260800	Seal, LP, 15mm	3	100	94734500	Spring	1	142a	36318151	Adj Injector housing	1
42a	90063500	Stop Ring Ø 25	1	101	36323370	Stem	1	142b	36260451	Fixed Injector (optional)	1
43	63216070	Int. Ring, 15mm	3	102	36322870	Guide bushing	1	143	701013	O-ring	1
43a	99183700	Screw M6x14	8	103	90385700	O-ring	1	144	36256370	Banjo bolt, Injector	1
44	90261200	Packing Assy, 15mm	3	104	90505200	Anti-Ext ring	1				

* 53150001 Oil Level Indicator Assembled W/O Screws and O-ring

REPAIR KITS

Kit No.	K137	K123	K124	K94	K159	K160	K162	K164	K166
Items in Kit	104 - 119	4 - 8 (11)	9, 10	120, 130, 132-137, 140, 143	17	42, 44	40	43	40 - 44
Pcs. in Kit	1	6	6	1	3	3	3	3	1

*Decrease torque by 20% if threads are lubricated.

TORQUE SPECS*

Item	Ft/lb	Nm
2	14.7	20
10	95.9	130
12	7.3	10
26	7.3	10
28	14.7	20
35	11.0	15
64	7.3	10



Ref 300531 Rev. E
10-17

GENERAL PUMP

DIMENSIONS* (INCHES)

J609b Models

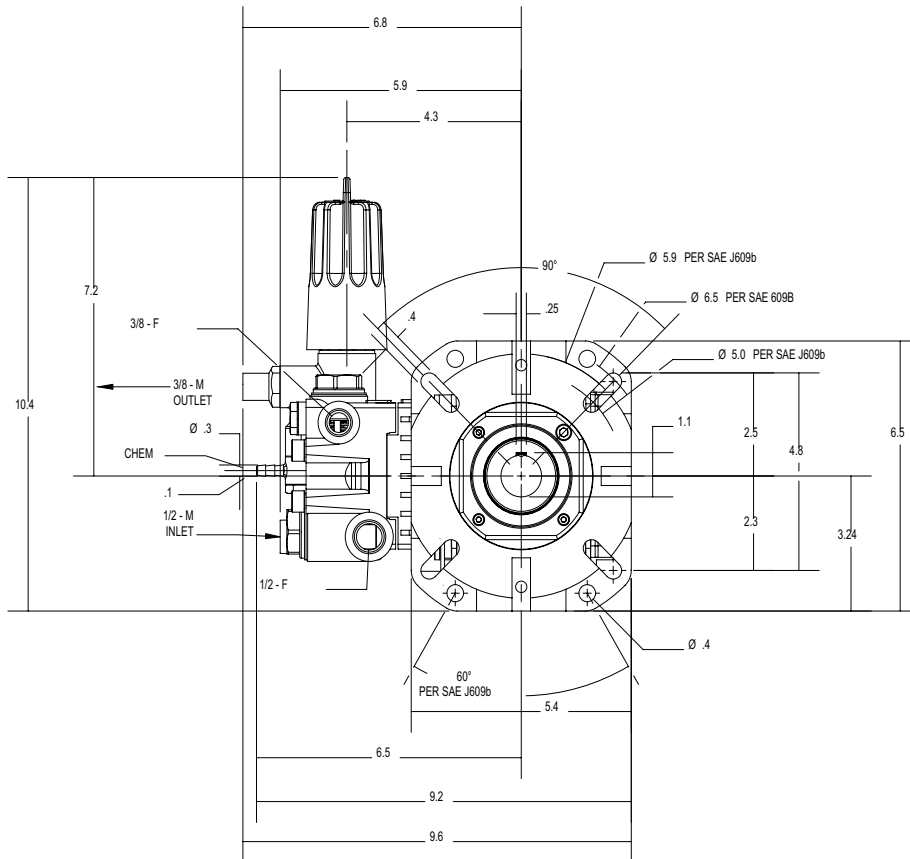
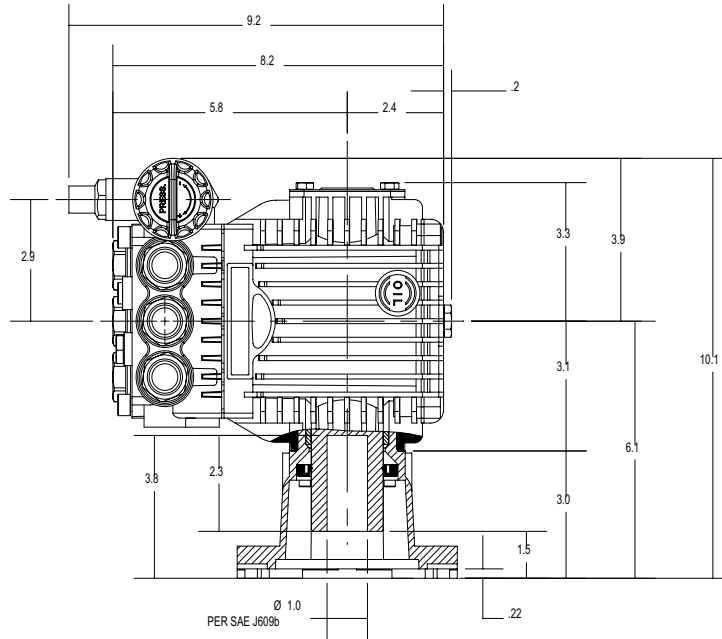

*Dimensions and/or specifications subject to change without notice