

66 Series, TSP

High Pressure Triplex Plunger Pump

FEATURES

- Compact, High Pressure
- Oversized roller bearings
- Fully anodized crankcase
- Innovative new seal design extends seal life
- New plunger design improves “thermal shock” resistance
- New valve cap design improves hydrostatic performance
- Also available in “L” left-handed versions



SPECIFICATIONS

Pump Model	TSP1619	TSP1619 Alternate Spec	TSP1621	TSP1819	TSP1821
Maximum GPM	3.6	4.3	4.3	5.0	5.5
Maximum PSI	7250	5800	6525	5100	
Horsepower	17.8 EBHP	17.0 EBHP	19.2 EBHP	17.5 EBHP	19.2 EBHP
Maximum RPM	1450	1750	1450		
Inlet PSI Maximum (Minimum)	125 PSI (30 PSI)				
Plunger Bore (mm)	.629 (16)	.629 (16)	.629 (16)	.709 (18)	.709 (18)
Plunger Stroke (mm)	.748 (19)	.748 (19)	.826 (21)	.748 (19)	.826 (21)
Oil Capacity	33.8 oz				
Maximum Fluid Temperature	165° F				
Inlet Port Thread	1/2" BSP-F				
Discharge Port Thread	3/8" BSP-F				
Shaft Diameter (mm)	.945 (24)				
Weight lb(kg)	51.8 (18.5)				
Dimensions	13.8" x 9.8" x 7.7"				

TRIPLEX

TRIPLEX



General Pump
is a member of
the Interpump Group



Ref 310046 Rev. Q
01-24



DIMENSIONS

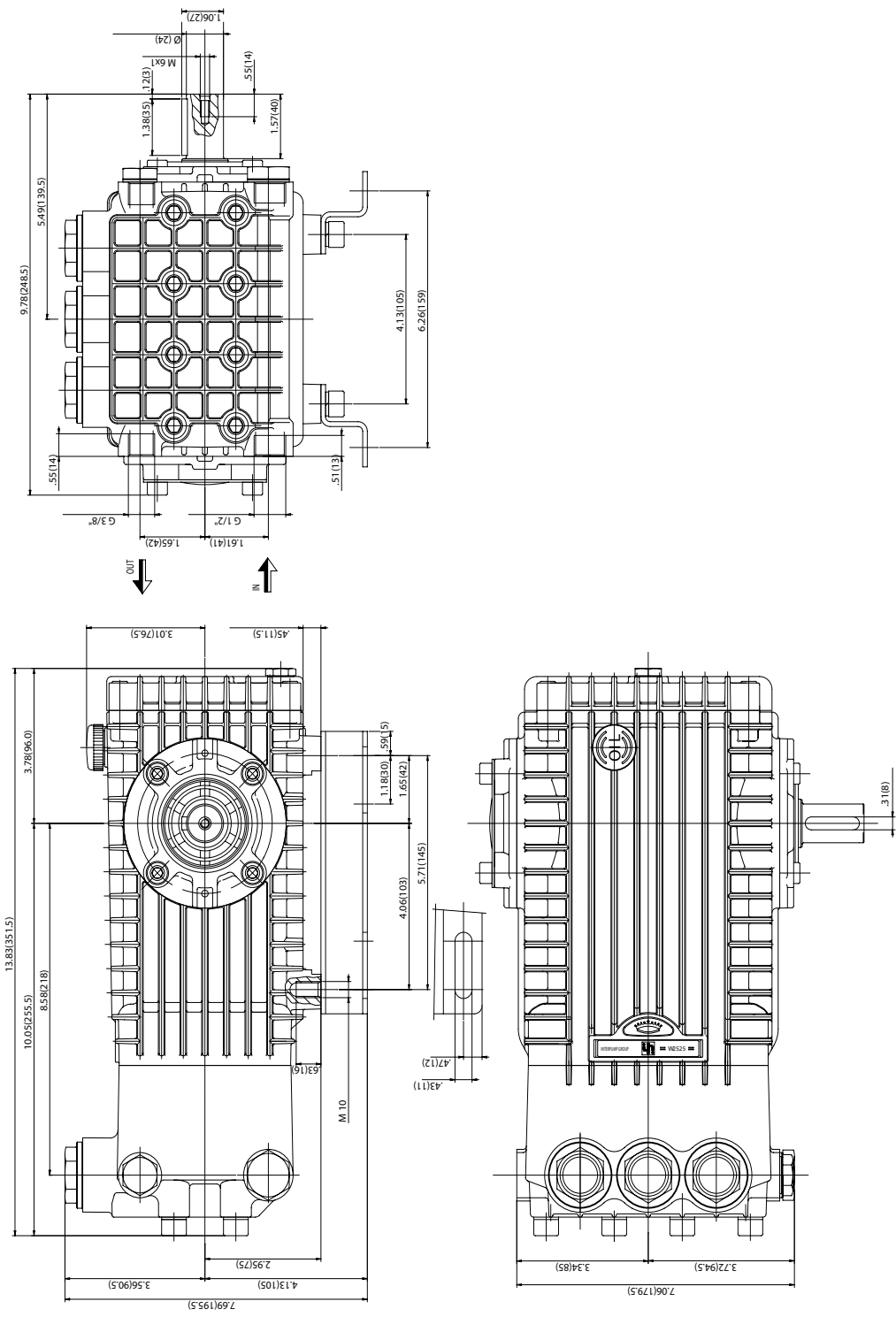

WARNINGS

WARNING: High Pressure Systems require a primary pressure regulating device (i.e. regulator, unloader) and a secondary pressure relief device (i.e. pop-off valve, relief valve). Failure to install such relief devices properly could result in personal injury or damage to pump or property. GP does not assume any liability or responsibility for the operation of the user's high pressure system.



WARNING: This product can expose you to chemicals including lead, which is known to the state of California to cause cancer and birth defects or other reproductive harm. For more information, go to www.P65Warnings.ca.gov

66 Series, TSP

GENERAL PUMP

A member of the Interpump Group

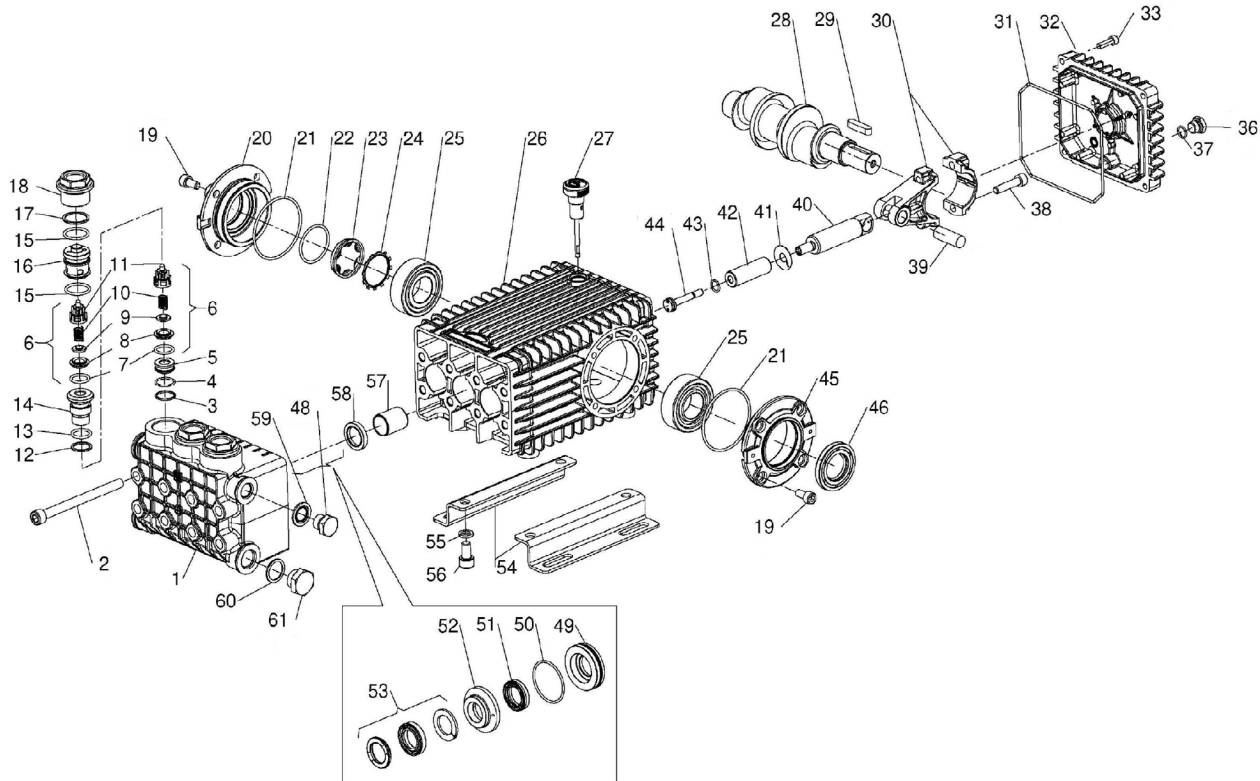

REPAIR KITS

ITEM	PART NO.	DESCRIPTION	QTY.	ITEM	PART NO.	DESCRIPTION	QTY.	ITEM	PART NO.	DESCRIPTION	QTY.
1.	66121041	Manifold 16 mm	1	21.	90391300	O-ring, 67.95 x 2.62	2	43.	701013	O-ring 10.82 x 1.78	3.
	66121141	Manifold 18 mm	1	22.	90387700	O-ring 39.34 x 2.62	1	44.	66219566	Plunger Bolt	3
	66124041	Manifold 16 mm, TSP1619	1	23.	70211801	Oil Sight Glass	1	45.	47151022	Side Cover, PTO	1
2.	99382000	Headbolt M10 x 120	8	24.	90075600	Retainer Clip	1	46.	90164800	Seal, Shaft 30 x 55 x 7	1
3.	90511800	Anti-ext ring	3	25.	91838000	Bearing	1	48.	98210000	Plug 3/8 x 13	2
4.	90359600	O-ring 18.77 x 1.78	3	26.	66010022	Crankcase	1	49.	66080270	Seal Retainer 16mm	3
5.	66210270	Spacer M12	3	27.	98210600	Dipstick, G3/8"	1		66080370	Seal Retainer 18mm	3
6.	36712101	Valve Assy.. Complete	6	28.	66020435	Crankshaft, TSP1621/TSP1821	1	50.	90361600	O-ring 34.65 x 1.78	3
7.	701115	O-ring 17.13 x 2.62	6		66020035	Crankshaft, TSP1819/TSP1619	1	51.	90263100	LP Seal 16mm	3
8.	36200366	Valve Seat	6	29.	91489200	Key	1		90265200	LP Seal 18mm	3
9.	36203266	Valve Poppet	6	30.	66030001	Connecting Rod	3	52.	66216270	Intermediate Ring 16mm	3
10.	94737600	Valve Spring	6	31.	90392200	O-ring 133.02 x 2.62	1		66216370	Intermediate Ring 18mm	3
11.	36202551	Valve Guide	6	32.	66160022	Cover, Crankcase	1	53.	90263400	HP Seal 16mm	3
12.	90511500	Anti-ext ring	3	33.	99188400	Screw M6 x 20	4		90265500	HP Seal 18mm	3
13.	90384300	O-ring 17.86 x 2.62	3	36.	98204250	Plug, G1/4" x 9	1	54.	47200074	Pump Rail	2
14.	66210166	Bushing	3	37.	701013	O-ring 10.82 x 1.78	1	55.	96710600	Washer M10	4
15.	90385700	O-ring 23.81 x 2.62	6	38.	99309900	Screw M8 x 35	6	56.	99364400	Screw M10 x 18	4
16.	66210070	Plug 19mm	3	39.	97740500	Wrist Pin	3	57.	90912600	Guide Bushing	3
17.	90516500	Anti-ext ring	3	40.	66050066	Piston Guide	3	58.	90162500	Seal, Pl. Rod 22 x 32 x 5.5	3
18.	66130141	Valve Cap	3	41.	96710100	Flinger Washer	3	69.	93185800	Gasket, Aluminum 3/8"	1
19.	99303900	Screw M8 x 16	8	42.	66040209	Plunger 16 x 54	3	63.	96751400	Washer, 21.5 x 27 x 1.5	1
20.	47151222	Side Cover	1		66040309	Plunger 18 x 54	3	64.	98217600	Plug, G1/2" x 10	1

REPAIR KITS

Kit No.	K02	K03	K15066	K174 (16mm)	K175 (16mm)	K180 (18mm)	K176 (18mm)
Pos. No.s Included In Kit	58	46	7, 8, 9, 10, 11, (6)	51, 53	49, 50, 51, 52, 53	51, 53	49, 50, 51, 52, 53
Number of Assemblies In Kit	3	1	6	3	1	3	1
Number of Cylinders Kit Will Service	3	N/A	3	3	1	3	1

TORQUE SPECS*

Item	N-M	Ft-lbs
2	45	33.2
18	180	132.8
19	20	14.8
33	10	7.4
36	20	14.8
38	20	14.8
44**	20	14.8
48	40	29.5
56	40	29.5
61	40	29.5

** Use Loc-tite 542

*Decrease torque by 20% if threads are lubricated.

GENERAL PUMP 1174 Northland Drive • Mendota Heights, MN 55120
 Phone: 651.686.2199 • Fax: 800.535.1745 • e-mail: sales@gpcompanies.com • www.generalpump.com

Ref 310046 Rev. Q
 01-24

