

## FEATURES

- SAE B 2/4 bolt mounting flange
- 7/8" Hollow keyed shaft
- Tach sensor port & pickup ring included
- Tach sensor optional
- Plunger design improves thermal shock resistance
- Valve cap improves hydrostatic performance



## SPECIFICATIONS

Pump Model	TSF1819HYD	TSF2019HYD	TSF2021HYD	TSF2219HYD	TSF2221HYD	TSF2819HYD	TSF2421HYD
Max Volume	6.3 GPM	7.6 GPM	8.5 GPM	9.3 GPM	10.2 GPM	12.1 GPM	12.0 GPM
Max Discharge Pressure	4,350 PSI	4,000 PSI	3,600 PSI	3,000 PSI		2,200 PSI	2,500 PSI
Horsepower (Hydraulic)	16 HHP	17.8 HHP	17.9 HHP	16.3 HHP	17.9 HHP	15.6 HHP	17.5 HHP
Max Pump Speed	1,750 RPM					1,450 RPM	1,750 RPM
Max Inlet Pressure	125 PSI						
Max Inlet Vacuum	9 ft. water / 7.9 in. Hg						
Plunger Bore	.709 in/18 mm	.787 in/20 mm		.866 in/22 mm		1.102 in/28 mm	.945 in/24 mm
Plunger Stroke	.748 in/19 mm		.826 in/21 mm	.748 in/19 mm	.826 in/21 mm	.748 in/19 mm	.826 in/21 mm
Oil Capacity	37.2 oz.						
Max Fluid Temp	165° F						
Inlet Port Thread	3/4"-14 BSP-F						
Discharge Port Thread	3/8"-19 BSP-F						
Shaft Diameter	7/8" Hollow keyed Shaft SAE B						
Weight	40.7 lbs/18.5 kg						
Dimensions	14.94" x 9.78" x 6.99"						

TRIPLEX

TRIPLEX



General Pump  
is a member of  
the Interpump Group



# 66 Series, TSF

## GENERAL PUMP

A member of the Interpump Group

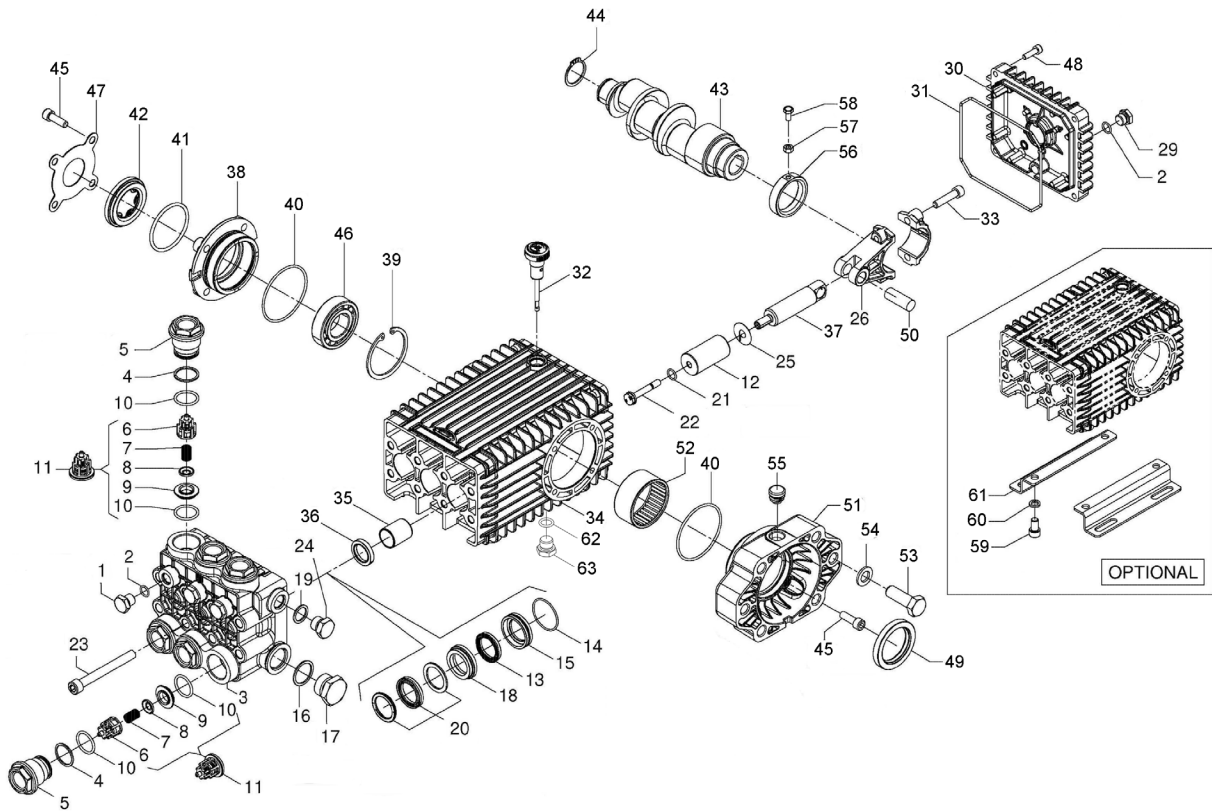

### PARTS LIST

No.	Part No.	Description	Qty
1	98204300	Plug G 1/4" x 13	3
2	701013	O-ring, Ø .426 x .070	4
3	66124541	Manifold, Ø 18 mm	1
	66120041	Manifold, Ø 20 mm	1
	66120141	Manifold, Ø 22 mm	1
	66120241	Manifold, Ø 24 mm	1
	66124641	Manifold, Ø 28 mm	1
4	90516500	Anti-ext ring, Ø24.7x29x1.5	6
5	66130041	Plug, M32x1.5x29.5	6
6	36203551	Valve Guide	6
7	94738800	Valve Spring, Ø 10x18.5	6
8	36203476	Valve Poppet	6
9	36203366	Valve Seat	6
10	90385700	O-ring, Ø23.81 x 2.62	12
11	36712701	Valve Assembly, Complete	6
12	66040309	Plunger, Ø 18 mm	3
	66040009	Plunger, Ø 20 mm	3
	66040109	Plunger, Ø 22 mm	3
	66040409	Plunger, Ø 24 mm	3
	66041009	Plunger, Ø 28 mm	3
13	90265200	LP Seal, Ø 18 mm	3
	90269000	LP Seal, Ø 20 mm	3
	90271500	LP Seal, Ø 22 mm	3
	90273800	LP Seal, Ø 24 mm	3
	90275300	LP Seal, Ø 28 mm	3
14	90361600	O-ring, Ø36.65 x 1.78	3
	66080370	Seal Retainer, Ø18 mm	3
	66080070	Seal Retainer, Ø20 mm	3
	66080170	Seal Retainer, Ø22 mm	3
	66080470	Seal Retainer, Ø24 mm	3
66082570	Seal Retainer, Ø28 mm	3	

No.	Part No.	Description	Qty
16	96770000	Washer, Ø26.5x32x1.5	1
17	98226800	Plug, G3/4"x16	1
18	66216370	Intermediate Ring, Ø18mm	3
	66216070	Intermediate Ring, Ø20mm	3
	66216170	Intermediate Ring, Ø22mm	3
	66216470	Intermediate Ring, Ø24mm	3
	66220070	Intermediate Ring, Ø28mm	3
19	96738000	Washer Ø 17.5 x 23 x 1.5	1
20	90265500	HP Seal, Ø18 mm	3
	90269200	HP Seal, Ø20 mm	3
	90271700	HP Seal, Ø22 mm	3
	90274100	HP Seal, Ø24 mm	3
	90275400	HP Seal, Ø28 mm	3
21	90358400	O-ring, Ø 10.82 x 1.78	3
22	66219566	Plunger Bolt	3
23	99380100	Headbolt, M10 x 90	8
24	98210000	Plug, G3/8" x 13	1
25	96710100	Flinger Washer	3
26	66030001	Connecting Rod, Comp.	3
29	98204250	Plug, G 1/4"x9	1
30	66160022	Rear Cover	1
31	90392200	O-ring Ø 133.02 x 2.62	1
32	98210600	Dipstick	1
33	99309900	Con-rod Screw	6
34	66010022	Crankcase	1
35	90912600	Bushing Ø 22 x 25 x 30	3
36	90162500	Ring, Ø 22.0 x 32.0 x 5.5	3
37	66050066	Piston Guide	3
38	59150022	Side Cover	1
39	90085000	Stop Ring, Ø 62	1
40	701147	O-ring, Ø 67.95 x 2.62	2

No.	Part No.	Description	Qty
41	90409700	O-ring, Ø 55.56 x 3.53	1
42	44211801	Sight Glass	1
43	F66021465	TSF1819HYD,TSF2019HYD, TSF2219HYD,TSF2819HYD Crankshaft, C.19	1
	F66021365	TSF2021HYD, TSF2221HYD, TSF2421HYD Crankshaft, C. 21	1
44	90066700	Stop Ring, Ø 30	1
45	99306900	Screw, M8 x 25	8
46	91837600	Roller Bearing	1
47	66150274	Side Cover	1
48	99188400	Screw, M6 x 20	4
49	90169000	Ring, Ø 45.0 x 62.0 x 8.0	1
50	99740500	Pin Ø 14 x 39	3
51	F10087222	Hydraulic Flange, SAE-B	4
52	91858700	Roller Pin Bushing	1
53	F99484800	Screw, M14 x 40	2
54	F96728200	Washer, Ø 15 x 24 x 2.5	2
55	F90206500	Plug, Ø 17	1
56	F71228971	Ring, Ø 40	1
57	92202500	Nut, M6 x 5	1
58	F70227034	Screw, M6 x 12	1
59	99364400	Screw, M10 x 18	4
60	96710600	Washer, Ø 12.2 x 16 x 2.5	4
61	47200074	Pump Feet	2
62*	90383300	O-ring, Ø 13.95 x 2.62	1
63*	98210050	Plug, G 3/8" x 13	1

\* Only on older manufactured pumps

### REPAIR KITS

KIT NO.	K02	K169	K180 (18mm)	K176 (18mm)	K170 (20mm)	K171 (20mm)	K172 (22mm)	K173 (22mm)	K181 (24 mm)	K182 (24mm)	K248 (28mm)	K247 (28mm)
POS. NO's INCLUDED IN KIT	36	6, 7, 8, 9, 10, (11)	13, 20	13, 14, 15, 18, 20	13, 20	13, 14, 15, 18, 20	13, 20	13, 14, 15, 18, 20	13, 20	13, 14, 15, 18, 20	13, 20	13, 14, 15, 18, 20
NUMBER OF ASSEMBLIES IN KIT	3	6	3	1	3	1	3	1	3	1	3	1
NUMBER OF CYLINDERS KIT WILL SERVICE	3	6	3	1	3	1	3	1	3	1	3	1

### DIMENSIONAL DRAWING

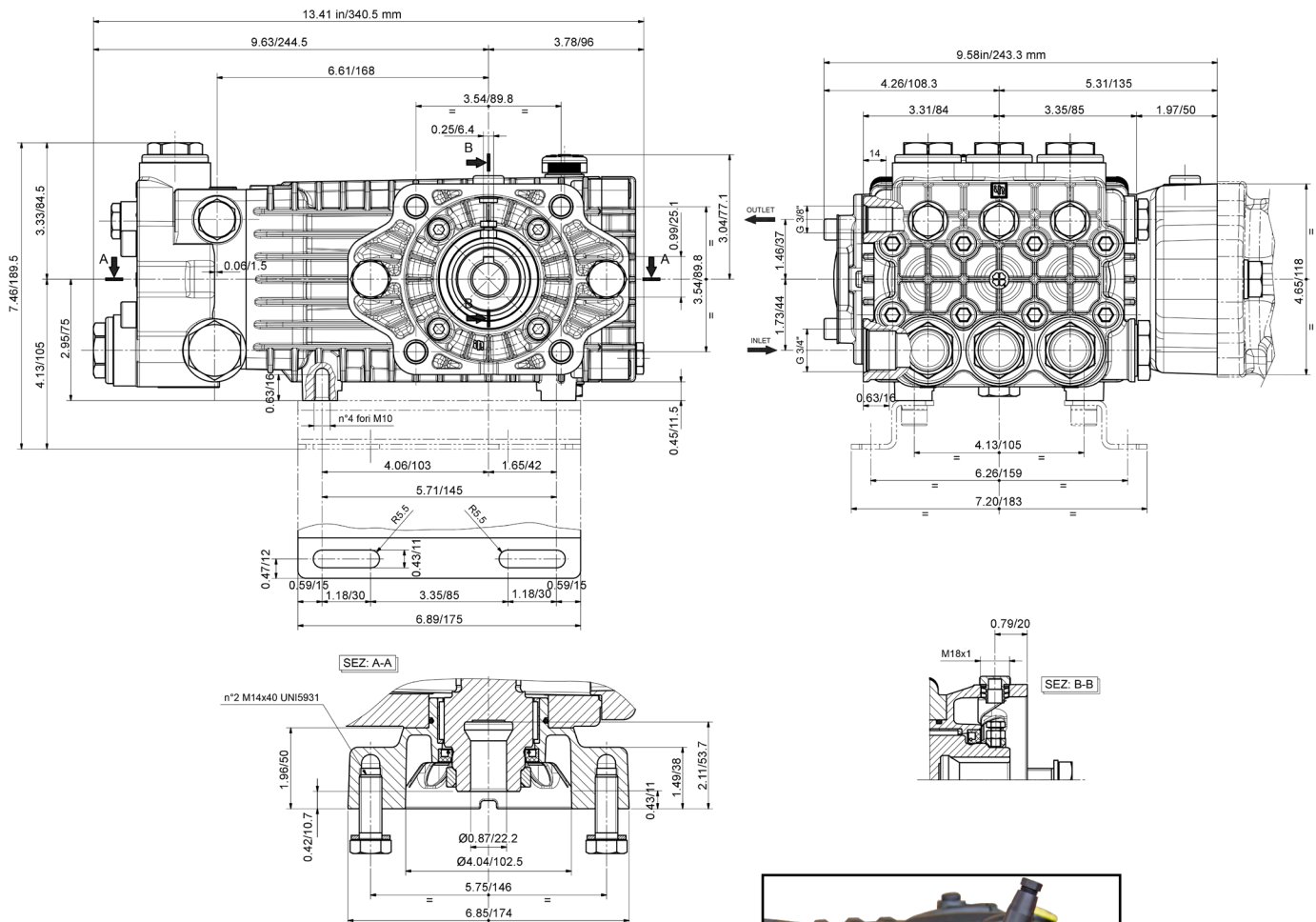

**Optional: ZRPM1 RPM Counter**  
 Inductive proximity sensor, c/w female connector M12 4 pin, IP67, field attachable, ring nut reduction M18 x 1.  
 Power Supply: 12/24 VDC

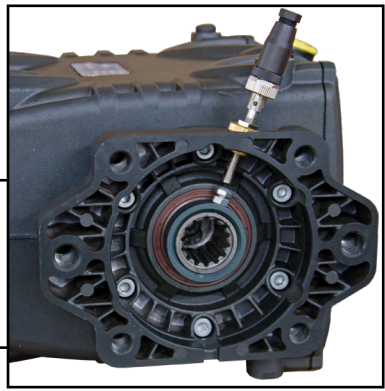

### TORQUE SPECS\*

POS.	Nm	Ft/lb
1	40	29.5
5	130	95.88
17	70	51.63
22	20	14.75
23	45	33.19
24	40	29.5
29	20	14.75
33	20	14.75
45	20	14.75
48	10	7.38
58	10	7.38
59	20	14.75
65	20	14.75

\* Decrease torque by 20% if threads are lubricated

### OIL CHANGING

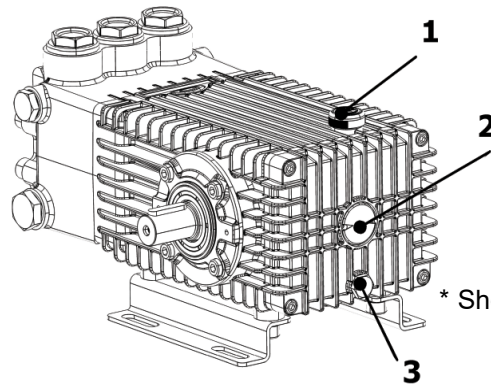

\* Shown with solid shaft

1. Oil changing must be done with the pump at operating temperature.
- 1.2 Put a container under the oil drain plug (3).
- 1.3 Remove the oil dipstick (1) and then the drain plug (3).
- 1.4 Wait until all the oil has drained out, then screw the drain plug (3) and tighten at the torque shown in the exploded diagram and above table.
- 1.5 Fill with new oil (General Pump Series 100) until the middle of the oil sight glass is reached, screw by hand the oil dipstick (1).

### WARNINGS



A suitably-calibrated over pressure valve must be installed, as well as the pressure regulating valve, must be installed on the high-pressure line.

The high-pressure pipes must be correctly sized for the system's maximum working pressure and used exclusively within the working pressure range indicated by the pipe manufacture and marked on the pipe itself.



The ends of the high-pressure pipes must be sheathed and secured to a solid structure, so as it avoid the risk of whiplash if the connections burst or break.

The pump transmission systems (joints, pulleys, belts, rotary shafts), must be suitably covered by a protective case.

If in doubt, do not hesitate to call the Interpump Group / General Pump Customer Service.



WARNING: This product can expose you to chemicals including lead, which is know to the state of California to cause cancer and birth defects or other reproductive harm. For more information, go to [www.P65Warnings.ca.gov](http://www.P65Warnings.ca.gov)