

## FEATURES

- 316 Stainless Steel manifold for maximum corrosion resistance
- The preferred pump frame in the pressure cleaning industry
- Solid ceramic plungers with continuously lubricated packings
- Over-sized connecting rods for maximum life
- Features patent-pending "high tech" packings:
  - dynamic low-pressure seal retainer
  - superior low-pressure seal
  - innovative intermediate ring
  - superior high-pressure seal

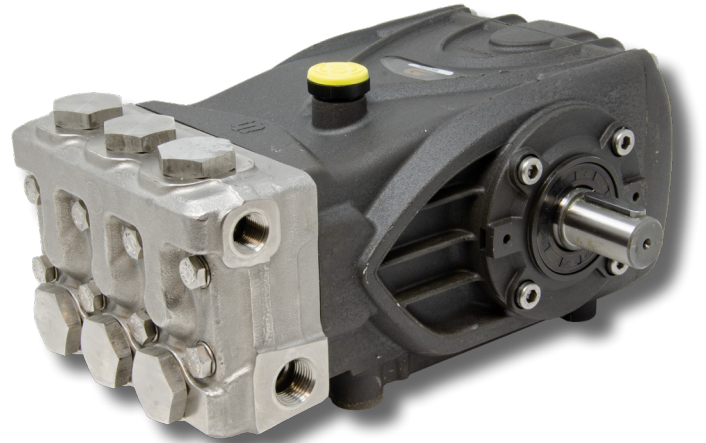

## SPECIFICATIONS

Pump Model	TS2010SS	TS2012SS	TS2012SS Alt. Spec	TS2016SS	TS2212SS	TS2212SS Alt. Spec
Max Volume	3.4 GPM	4.0 GPM	4.75 GPM	5.55 GPM	4.75 GPM	5.55 GPM
Max Discharge Pressure	2200 PSI	3000 PSI	2200 PSI	3000 PSI	2200 PSI	
Horsepower	5.12 EBHP	8.2 EBHP	7.2 EBHP	11.4 EBHP	7.2 EBHP	8.4 EBHP
Max Pump Speed	1450 RPM	1450 RPM	1750 RPM	1450 RPM	1750 RPM	
Max Inlet Pressure	125 PSI					
Max Inlet Vacuum	9 ft. Water / 7.9 in. Hg					
Plunger Bore	.787 in. / 20 mm				.866 in. / 22 mm	
Plunger Stroke	.394 in / 10 mm	.472 in. / 12 mm		.630 in. / 16 mm	.472 in. / 12 mm	
Oil Capacity	40.6 oz					
Max Fluid Temp	185° F					
Inlet Port Thread	1/2-14 BSP-F					
Discharge Port Thread	3/8-19 BSP-F					
Shaft Diameter	.945 in. / 24 mm					
Weight	31 lbs.					
Dimensions	12.42 in. x 9.29 in. x 7.09 in.					

TRIPLEX

TRIPLEX

# 47 Series SS - Stainless Steel

**GENERAL PUMP** *A member of the Interpump Group*

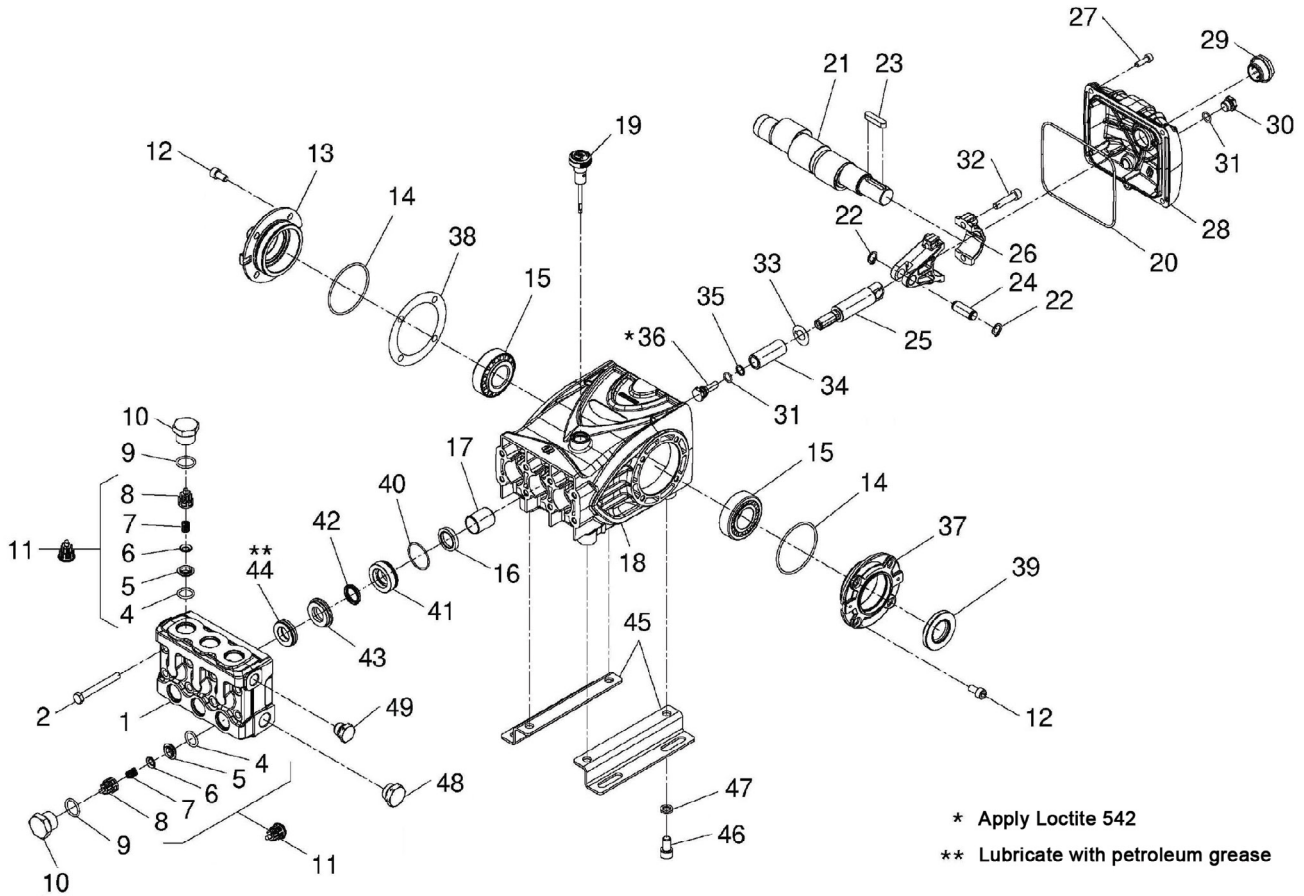

## PART LIST

No.	Part No.	Description	Qty.	No.	Part No.	Description	Qty.	No.	Part No.	Description	Qty.
1.	47121936	Manifold, SS	1					36.	47219766	Screw, Plunger	3
2.	99320700	Screw, M8 x 70	8					37.	47151022	Cover, Crankcase	3
4.	90384100	O-ring, Ø17.13 x 2.62	8	21.	47021835	Crankshaft, (TS2012SS, TS2212SS)	1	38.	97567800	Shim	2
5.	36200366	Seat, Valve	6		47021935	Crankshaft, (TS2012SS)	1	39.	90164800	Seal, Oil	1
6.	36200176	Plate, Valve	6	22.	90055700	Ring, Snap	6	40.	90361600	O-ring, Ø34.65 x 1.78	3
7.	94737300	Spring, Ø9.4 x 14.8	6	23.	91489000	Key	1	41.	47081566	Retainer, Packing	3
8.	36202251	Guide, Valve	6	24.	97738000	Pin, Wrist	3	41.	47081666	Retainer, Packing (TS2212SS)	
9.	90384700	O-ring, Ø20.29 x 2.62	6	25.	47050766	Guide, Plunger	3	42.	90272500	Packing	3
10.	98223000	Cap, SS	6	26.	47030001	Connecting Rod	3	42.	90230000	Packing (TS2212SS)	3
11.	36713001	Valve Assembly	6	27.	99188300	Screw, M6 x 20	5	43.	47217666	Ring, Head, Ø20	
12.	99303800	Screw, M8 x 16	8	28.	47160622	Cover, Crankcase	1	43.	47217766	Ring, Head, Ø22 (TS2212SS)	
13.	47151122	Cover, Crankcase	1	29.	97596800	Oil Indicator	1	44.	90226200	Intermed. Ring	3
14.	90391300	O-ring, Ø67.95 x 2.62	2	30.	98204000	Plug	1	44.	90231000	Intermed. Ring (TS2212SS)	
15.	640047	Bearing, Roller	2	31.	90358500	O-ring, 10.82 x 1.78	4	45.	47200074	Pump Feet	2
16.	90162500	Seal, Oil, Ø22 x 32 x 2.5	3	32.	99309900	Screw, M8 x 35	6	46.	99364400	Screw, M10 x 18	4
17.	90912600	Bushing, Ø22 x 25 x 30	3	33.	96728700	Washer,	3	47.	96710600	Washer, Ø10	4
18.	47010822	Crankcase	1	34.	47040409	Plunger, 20 mm	3	48.	98218000	Plug, G 1/2 x 10	1
19.	98210600	Oil Dip Stick	1	34.	47040509	Plunger, 22 mm (TS2212SS)			49.	96751400	Plug, G 3/8 x 13
20.	90392200	O-ring, Cover	1	35.	90506700	Ring, Back-up	3				

## DIMENSIONS (Inches/mm)

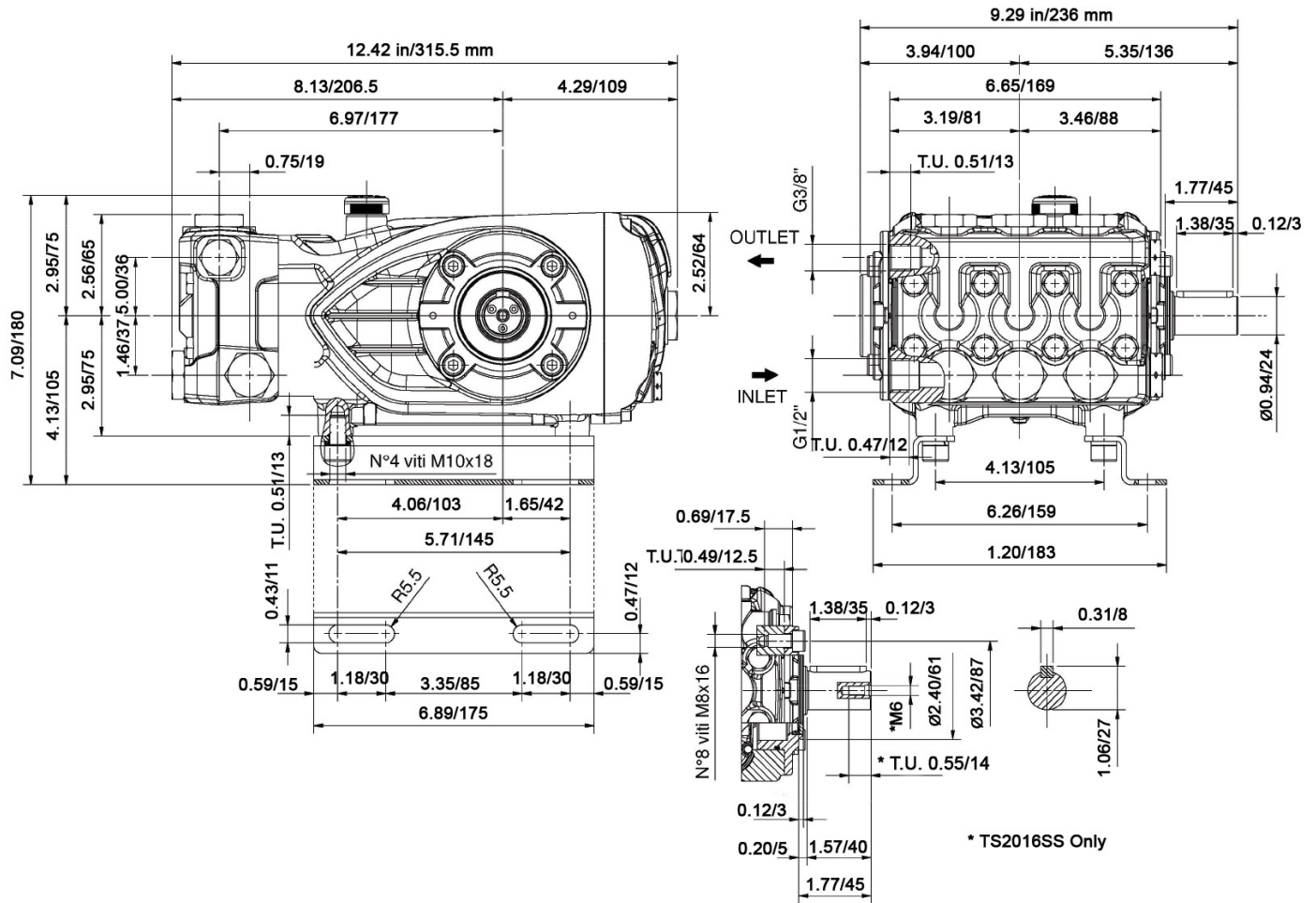

## REPAIR KITS

KIT NO.	2	3	192	238 Ø20	239 Ø20	202 Ø22	240 Ø22
ITEM NO's INCLUDED IN KIT	16	39	4, 5, 6 7, 8 (11)	42, 44	40, 41, 42, 43, 44	42, 44	40, 41, 42, 43, 44
NUMBER OF ASSEMBLIES IN KIT	3	2	6	6	1	6	1
NUMBER OF CYLINDERS KIT WILL SERVICE	3	--	6	3	1	3	1

## TORQUE SPECS\*

Pos.	Ft/lb	N-M
2	18.4	25
10	95.9	130
12	14.8	20
27	7.4	10
29	8.9	12
30	14.8	20
32	14.8	20
36	14.8	20
46	29.5	40
48	29.5	40
49	29.5	40

\* Decrease torque by 20% if threads are lubricated

**WARNING: High Pressure Systems require a primary pressure regulating device (i.e. regulator, unloader) and a secondary pressure relief device (i.e. pop-off valve, relief valve). Failure to install such relief devices properly could result in personal injury or damage to pump or property. GP does not assume any liability or responsibility for the operation of the user's high pressure system.**



WARNING: This product can expose you to chemicals including lead, which is known to the state of California to cause cancer and birth defects or other reproductive harm. For more information, go to [www.P65Warnings.ca.gov](http://www.P65Warnings.ca.gov)