

## 20 mm bore - Triplex Plunger Pumps

### FEATURES

- The preferred pump frame in the pressure cleaning cleaning industry
- Forged brass manifold
- Large-capacity, die-cast anodized aluminum, oil-bath crankcase
- Over-sized connecting rods for maximum life
- Heavy-duty tapered roller bearing
- Solid ceramic plungers with continuously lubricated packings
- Unitized stainless steel inlet and discharge valves



### SPECIFICATIONS

Pump Model	TS1041	TS1531
Maximum Volume	8.0 GPM	7.92 GPM
Maximum Discharge Pressure	1600 PSI	2175 PSI
Maximum Pump Speed	1450 RPM	
Maximum Inlet Pressure	125 PSI	
Maximum Inlet Vacuum	9 ft. water (7.9 Hg)	
Plunger Bore (in / mm)	.787 in. / 20 mm	
Plunger Stroke (in / mm)	.866 in. / 22 mm	
Oil Capacity	50.7 oz.	
Maximum Fluid Temperature	165°F	
Inlet Port Thread	3/4-14 BSP-F	
Discharge Port Thread	3/8-19 BSP-F	
Shaft Diameter	1.378 in. / 35 mm	
Weight	46 lbs.	
Dimensions	12.9" x 11.9" x 7.3"	

### DIMENSIONAL DRAWING

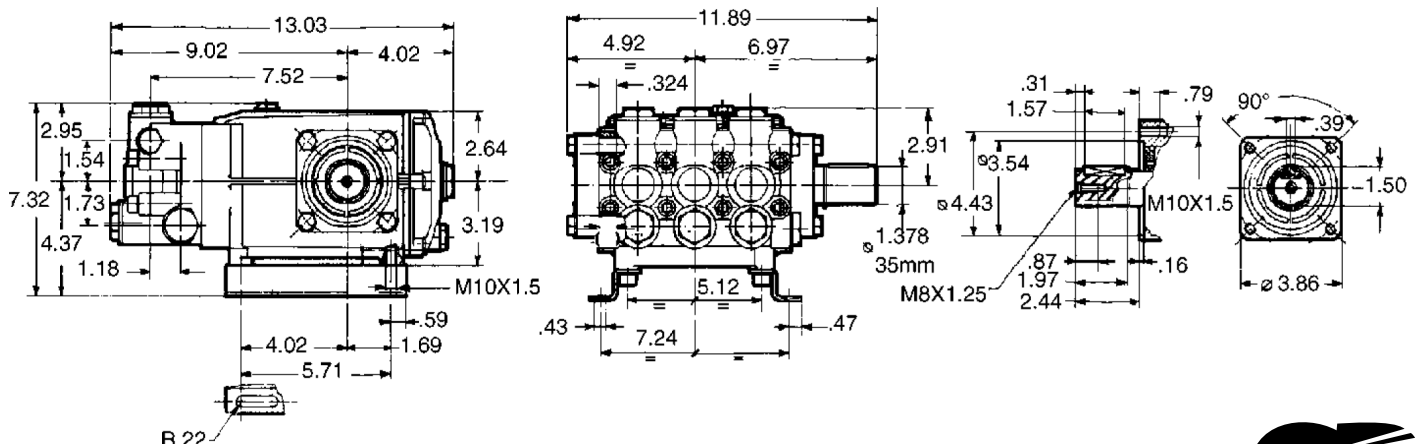

TRIPLEX

TRIPLEX



General Pump is a member of the Interpump Group



# T Series 69 - 20 mm Bore

# GENERAL PUMP A member of the Interpump Group

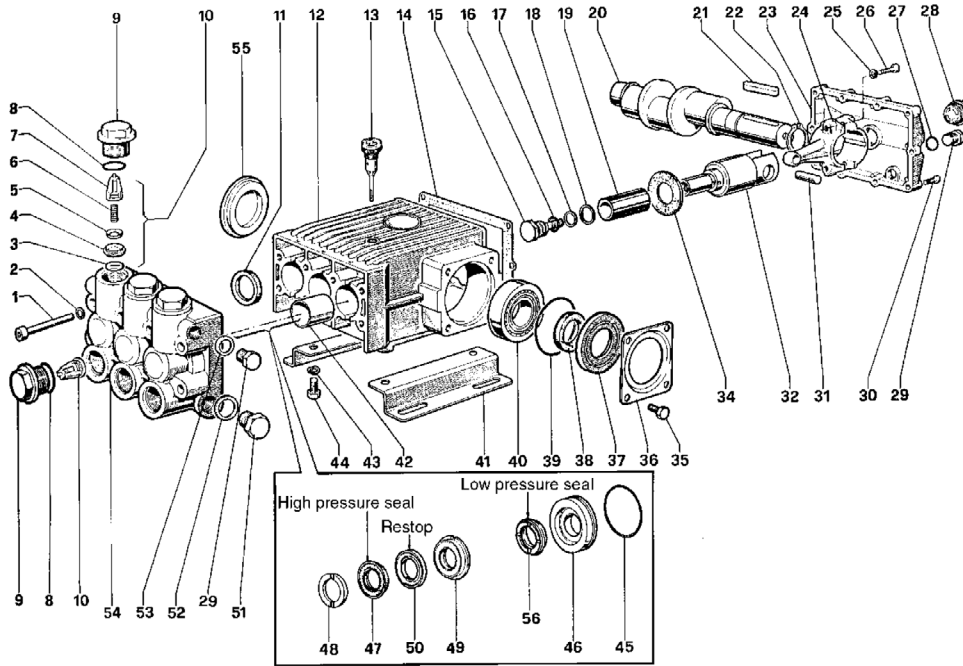

## PARTS LIST

ITEM	PART NO.	DESCRIPTION	QTY.	ITEM	PART NO.	DESCRIPTION	QTY.	ITEM	PART NO.	DESCRIPTION	QTY.
1.	99378700	Screw	8	20.	69021035	Crankshaft	1	39.	90413100	O-ring	2
2.	96710400	Washer	16	21.	91496900	Key	1	40.	91848000	Bearing	2
3.	90385900	O-ring	6	22.	90069500	Cir-clip	1	41.	47200074	Foot	2
4.	36201766	Valve Seat	6	23.	69160022	Crankcase Cover	1	42.	90916200	Bushing	3
5.	36201876	Valve Plate	6	24.	69030001	Connecting Rod	3	43.	96710600	Washer	4
6.	94739400	Spring	6	25.	69030301	Connecting Rod (TS1531)	3	44.	99364400	Screw	4
7.	36200851	Valve Guide	6	26.	96701400	Washer	6	45.	90388500	O-ring	3
8.	90405100	O-ring	6	27.	99309900	Screw	6	46.	69080470	Packing Retainer	3
9.	98231200	Cap	6	28.	90383300	O-ring	1	47.	90270500	Packing	3
10.	36706001	Valve Unit	6	29.	97596800	Indicator	1	48.	47100051	Head Ring	3
11.	90165600	Seal	3	30.	98210000	Cap	2	49.	47216970	Intermediate Ring	3
12.	69010022	Cover	1	31.	99186700	Screw	9	50.	90270400	Ring	3
13.	98210600	Oil Dipstick	1	32.	97739800	Plunger Pin	3	51.	98226500	Cap	1
14.	69211984	Cover Gasket	1	33.	69050254	Plunger Guide	3	52.	96770000	Washer	1
15.	47219566	Plunger Bolt	3	34.	69211747	Flinger	3	53.	96738000	Washer	1
16.	90358500	O-ring	3	35.	99363600	Screw	8	54.	69121041	Manifold	1
17.	90506700	Anti-ext. Ring	3	36.	68150074	Crankcase Cover	2	55.	69211651	Spacer	1
18.	96728000	Washer	3	37.	69211551	Spacer	1	56.	90271000	Seal, L.P., 20 mm	69, 82 3
19.	47040409	Plunger (20 mm)	3	38.	90167200	Ring	1				

## REPAIR KITS

KIT NO.	7	32	37	54	57	62	69	71	82
ITEM NO's INCLUDED IN KIT	48	38	11	15, 16, 17	45, 46	3, 4, 5	47, 50	49, 50	45, 46, 47
NUMBER OF ASSEMBLIES IN KIT	6	2	3	3	3	6	3	3	1
NUMBER OF CYLINDERS KIT WILL SERVICE	3	2	3	3	3	3	3	3	1

## TORQUE SPECS\*

Position	Ft.-Lbs	Nm
1	29.4	40
9	110.6	150
15	14.7	19.9
26	14.7	19.9
28	13.2	17.9
29	29.4	39.8
30	7.3	9.9
35	29.4	39.8
44	29.4	39.8
51	51.5	69.8

\* Decrease torque by 20% if threads are lubricated

**WARNING: High Pressure Systems require a primary pressure regulating device (i.e. regulator, unloader) and a secondary pressure relief device (i.e. pop-off valve, relief valve). Failure to install such relief devices properly could result in personal injury or damage to pump or property. GP does not assume any liability or responsibility for the operation of the user's high pressure system.**



WARNING: This product can expose you to chemicals including lead, which is known to the state of California to cause cancer and birth defects or other reproductive harm. For more information, go to [www.P65Warnings.ca.gov](http://www.P65Warnings.ca.gov)

