

TC Series "60"

Triples Plunger Pump, 3/4" Hollow Shaft Flanged for Direct Couple To Gas Engine

FEATURES

- Compact design
- 3/4" hollow shaft, flanged for direct couple to gasoline engines (SAE J609A)
- Oversized bearings for long life
- New generation seal system for longer life
- Forged brass manifold



SPECIFICATIONS

Pump Model	TC1506G	TC1507G	TC1508G	TC1509G
Maximum Volume	2.60 GPM	3.00 GPM	3.30 GPM	4.00 GPM
Maximum Discharge Pressure	2700 PSI		2500 PSI	
Horsepower	7.21 GHP	8.32 GHP	8.48 GHP	10.27 GHP
Maximum Pump Speed	3400 RPM			
Maximum Inlet Pressure	125 PSI			
Minimum Inlet Pressure	Flooded			
Plunger Bore (in / mm)	.591 in / 15 mm			
Plunger Stroke (in / mm)	.256 in / 6.5 mm	.283 in / 7.2 mm	.315 in / 8.0 mm	.370 in / 9.4 mm
Oil Capacity	11.8 oz			
Maximum Fluid Temperature	165°F			
Inlet Port Thread	1/2" - 14 BSP-F			
Discharge Port Thread	3/8" - 19 BSP-F			
Shaft Diameter	.748 in / 19 mm			
Weight	14.6 lbs			
Dimensions	7.6 x 7.6 x 5.0 in			

DIMENSIONAL DRAWING

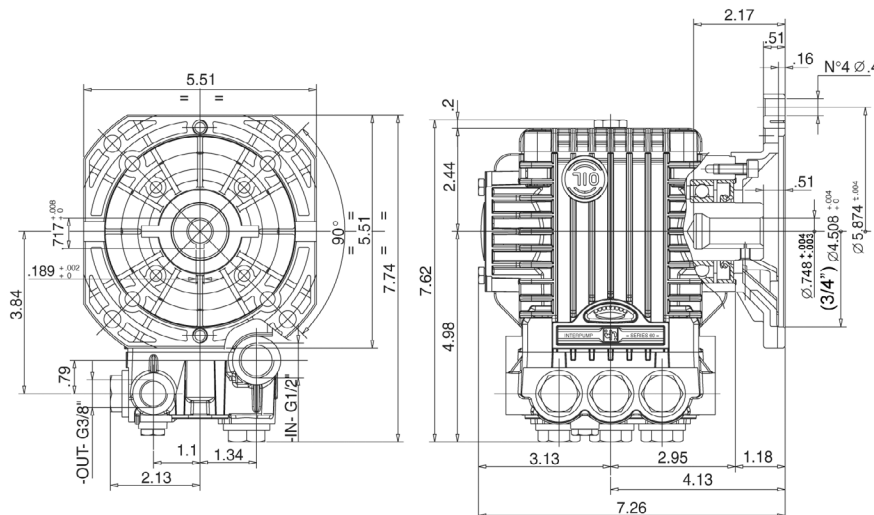

TRIPLEX

TRIPLEX

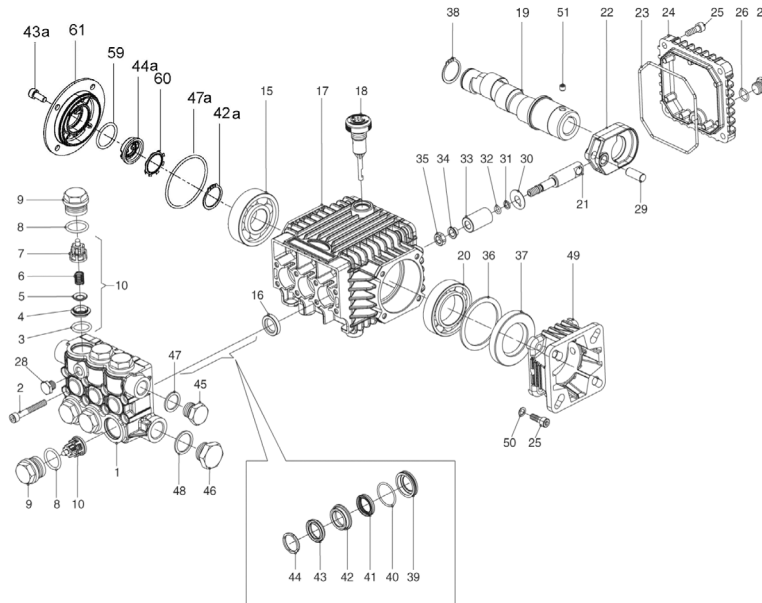

PARTS LIST

ITEM	PART NO.	DESCRIPTION	QTY.	ITEM	PART NO.	DESCRIPTION	QTY.	ITEM	PART NO.	DESCRIPTION	QTY.
1.	60120041	Manifold, 15 mm	1	21.	60050066	Plunger Guide	3	40.	90360400	O-ring,	3
2.	99195000	Screw, M6 x 45	8	22.	60030022	Connecting Rod	3	41.	90260800	Seal, LP, 15 mm	3
3.	701115	O-ring	6	23.	90391800	O-ring, Cover	1	42.	60216070	Intermediate Ring, 15	3
4.	36200366	Valve Seat	6	24.	60160022	Rear Crankcase Cover	1	42a.	90063500	Stop Ring Ø 25	1
5.	36711501	Valve	6	25.	99186700	Screw, M6 x 18	8	43.	90262000	Seal, HP, 15mm	3
6.	94737600	Spring	6	26.	701013	O-ring	1	43a.	99183700	Screw M6x14	4
7.	36202551	Valve Cage	6	27.	98204100	Plug, 1/4" G	1	44.	51100051	Head Ring, 15mm	3
8.	701002	O-ring	6	28.	98196600	Plug, 1/8" G	1	44a.	53210851	Oil Level Indicator	1
9.	98221400	Valve Cap	6	29.	97733300	Wrist Pin	3	45.	98210000	Plug, 3/8" G	1
10.	36711501	Valve Assembly	6	30.	96707000	Washer	3	46.	98217600	Plug, 1/2" G	1
15.	91832800	Ball Bearing	1	31.	660024	Anti-ext. Ring	3	47.	96738000	Gasket, Alum., 3/8"	1
16.	710002	Oil Seal	3	32.	90357300	O-ring	3	47a.	90389800	O-ring Ø 56.82x2.62	1
17.	60010022	Crankcase	1	33.	60040009	Ceramic Plunger, 15mm	3	48.	96751400	Gasket, Alum., 1/2"	1
18.	98210300	Oil Dip Stick	1	34.	44211570	Bushing	3	49.	10065222	Flange	1
19.	60027165	Crankshaft, TC1506G	1	35.	92221600	Nut, M8	3	50.	203510	Washer	4
	60027365	Crankshaft, TC1507G	1	36.	60210189	Spacer	1	51.	99179000	Screw, M6	1
19.	60027565	Crankshaft, TC1508G	1	37.	90167500	Oil Seal	1	59.	90385900	O-ring Ø 25.07x2.62	1
	60027865	Crankshaft, TC1509G	1	38	90063500	Circlip	1	60.	90067100	Stop Ring	1
20.	91846400	Bearing	1	39.	60080070	Packing Retainer	3	61.	58150122	Side Cover	1

* 53150001 Oil Level Indicator Assembled W/O Screws and O-ring

REPAIR KITS

KIT NO.	K83	K123	K196 (15mm)	K198 (15mm)	K200 (15mm)	K226 (15mm)
ITEM NO's INCLUDED IN KIT	16	3, 4, 5, 6, 7 (10)	41, 43, 44	42	39, 40	39, 40, 41, 42, 43, 44
NUMBER OF ASSEMBLIES IN KIT	3	6	3	3	3	1
NUMBER OF CYLINDERS KIT WILL SERVICE	3	3	3	3	3	1

TORQUE SPECS*

Pos.	Ft/lb	Nm
2	8.8	12
9	59.0	80
11	7.4	10
25	7.4	10
27	14.7	20
28	9.6	13
35	11.1	15
44	29.5	40
46	29.5	40

* Decrease torque by 20% if threads are lubricated

WARNING: High Pressure Systems require a primary pressure regulating device (i.e. regulator, unloader) and a secondary pressure relief device (i.e. pop-off valve, relief valve). Failure to install such relief devices properly could result in personal injury or damage to pump or property. GP does not assume any liability or responsibility for the operation of the user's high pressure system.

WARNING: This product can expose you to chemicals including lead, which is known to the state of California to cause cancer and birth defects or other reproductive harm. For more information, go to www.P65Warnings.ca.gov

