

FEATURES

- Forged brass manifold
- Die-cast, anodized aluminum, oil-bath crankcase
- Solid ceramic plungers with continuously lubricated packings
- The original Interpump unitized stainless steel K01 inlet and outlet valves
- Standard 24 mm solid shaft for pulley mounting
- Flex coupling and bell housing available for direct drive
- Ideal for all general cleaning/washing applications
- Also available in "L" left-handed and aluminum manifold versions



SPECIFICATIONS

Pump Model	T991	T911	T9951	T9971	TT9351	TT9441
Maximum Volume	4.0(3.5) GPM	3.5 GPM	3.5 GPM	4.0 GPM	3.5 GPM	4.4 GPM
Maximum Discharge Pressure	1100(1500) PSI	1400 PSI	1500 PSI	2000 PSI	2500 PSI	
Maximum Pump Speed	1750/(1450) RPM	1450 RPM	1750 RPM		3400 RPM	
Maximum Inlet Pressure	125 PSI					
Maximum Inlet Vacuum	9 ft. water (7.9 in. Hg)					
Plunger Bore	.787 in. / 20 mm				.591/15 mm	
Plunger Stroke (in./mm)	.394 / 10		.335/8.5	.394/10	.335/8.5	.394/10
Crankcase Oil Capacity	15.2 oz.					
Maximum Fluid Temperature	165° F					
Inlet Port Thread	1/2-14 BSP-F					
Discharge Port Thread	3/8-19 BSP-F					
Shaft Diameter	.945 in. / 24 mm					
Weight	19 lbs.					
Dimensions	9.3 x 8.3 x 5.4					

DIMENSIONAL DRAWING

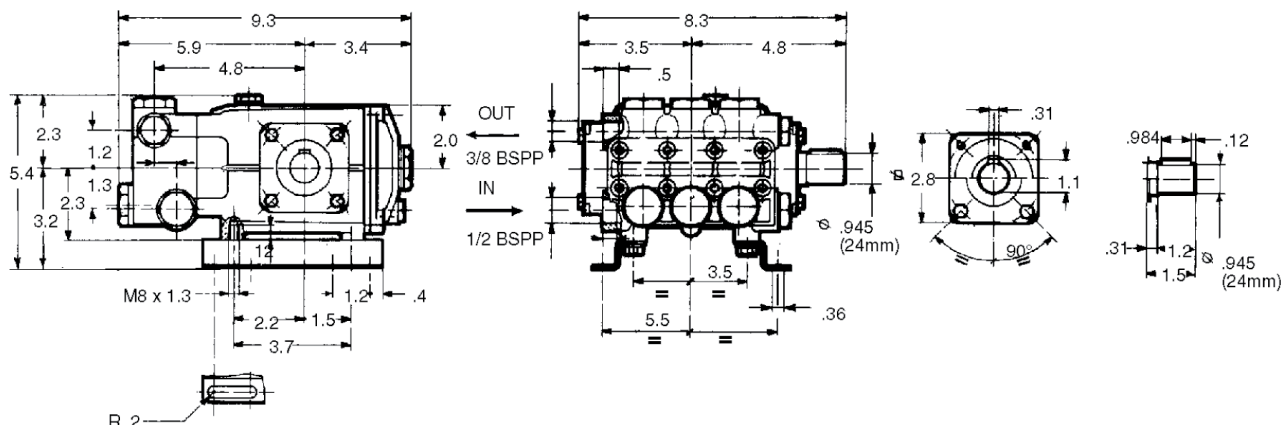

TRIPLEX

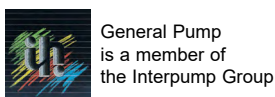

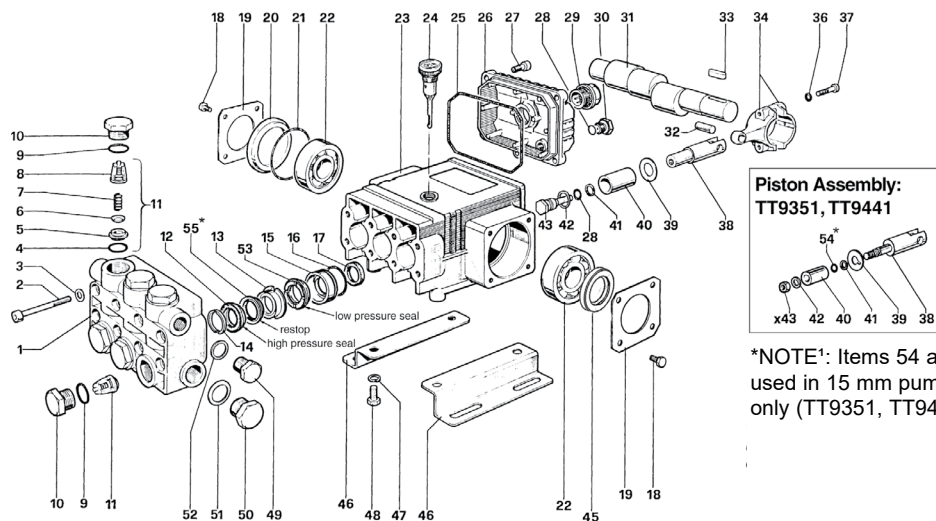

NOTE: Items 54 and 55 used in 15 mm pumps only (TT9351, TT9441)

PARTS LIST

ITEM	PART NO.	DESCRIPTION	KIT NO.	QTY.	ITEM	PART NO.	DESCRIPTION	KIT NO.	QTY.	ITEM	PART NO.	DESCRIPTION	KIT NO.	QTY.
1.	50120741	Manifold, Brass		1	19.	50150074	Cover, Crankcase	2		39.	96728600	Washer, M14x28x5	6	3
	50120541	Manifold, Brass (TT9352, TT9441)			20.	50211651	Spacer	1			96707000	Washer (TT9351, TT9441)	3	
	50120022	Manifold, Aluminum (T911)			22.	91832900	Bearing, Ball	2		40.	50040409	Plunger (20 mm)	3	
2.	99317500	Screw, M8 x 60		8	23.	50010422	Crankcase	1			52040009	Plunger (15mm-TT9351, TT9441)		
3.	96701400	Washer, M8.4 x 13 x.8		8	24.	98210300	Oil Dip Stick	1		41.	90506700	Ring, Back-up	6	3
4.	90384100	O-ring, .674x103		1	25.	90392000	O-ring, 3.987x.103	1			90502200	Ring, Back-up (TT9351, TT9441)		
5.	36200366	Seat, Valve		1	26.	50160022	Cover	1		42.	96728000	Washer, M14x18.5x.055	6	3
6.	36200176	Plate, Valve		1	27.	99183700	Screw, M6x14	5			96700800	Washer (TT9351, TT9441)		
7.	94737600	Spring		1	28.	90358500	O-ring, .426x.070	6	4	43.	47219566	Screw, Plunger	6	3
8.	36200251	Guide, Valve		1	29.	97596800	Indicator, Oil	1		x43	92221600	Nut, M8, SS		3
9.	90384700	O-ring, .797x.103		4	30.	98204100	Cap, 1/4-BSP	1		45.	90164100	Seal, Oil		1
10.	98222000	Cap, M24x2x16		4	31.	50021835	Crankshaft (T991, T911)	1		46.	50200074	Feet, Pump		2
11.	36703201	Valve Assembly		1		50021935	Crankshaft (9951)	1		47.	96701600	Washer		4
12.	90270300	Packing	19,27	3		50020135	Crankshaft (T9971, TT9441)	1		48.	99303700	Screw		4
	90262000	(TT9351, TT9441)	88,92	3		50020535	Crankshaft (TT9351)	1		49.	98210000	Cap, 3/8-BSP		1
13.	50216670	Ring, Int.	20,27	3	32.	97733000	Pin, Wrist	3		50.	98217600	Cap, 1/2-BSP		1
	52216670	(TT9351, TT9441)	89,92	3	33.	640048	Key	1		51.	96751400	Washer, M21.5x27x1.5		1
14.	50100051	Ring, Head	21,27	3	34.	50030001	Rod, Connecting, Alum.	3		52.	96738000	Washer, M17.5x23x1.5		1
	51100051	(TT9351, TT9441)	90,92	3		50030301	Rod, Connecting, Brass	3		53.	90269800	Seal, LP, 20mm	19,27	3
15.	50080570	Retainer, Packing	22,27	3	36.	96693900	Washer, M6.4x10x.7	6			90261700	(TT9351, TT9441)	88,92	3
	52080570	(TT9351, TT9441)	91,92	3	37.	99192700	Screw, M6x35	6		54.	90357200	O-ring, .208" x .070"		3
16.	90361200	O-ring, 1.239x.070	22,27	3	38.	50050156	Guide, Plunger	3		55.	90262200	Restop Ring	88, 92	3
17.	90161400	Seal, Oil	23	3		52050056	Guide, Plunger (TT9351, TT9441)							
18.	99180700	Screw, M6x10		8										

REPAIR KITS

KIT NO.	1	4	6	19 or 88	20 or 89	21 or 90	22 or 91	23	27 or 92
ITEM NO's INCLUDED IN KIT	4, 5, 6 7, 8 (11)	9, 10	28, 39, 41, 42, 43	12, 53, 55* *15 mm only	13	14	15, 16	17	12, 13, 14, 15, 16, 53, 55* *15 mm only
NUMBER OF ASSEMBLIES IN KIT	6	6	3	3	3	6	3	3	1
NUMBER OF CYLINDERS KIT WILL SERVICE	3	3	3	3	3	3	3	3	1

TORQUE SPECS*

Pos.	Ft/lb	N-M
2	14.7	19.2
10	95.9	130
18	7.3	10
27	7.3	10
29	8.8	12
30	14.7	19.2
37	8.8	12
43	14.7	19.2
48	14.7	19.2
49	29.4	40
50	29.4	40

* Decrease torque by 20% if threads are lubricated

WARNING: High Pressure Systems require a primary pressure regulating device (i.e. regulator, unloader) and a secondary pressure relief device (i.e. pop-off valve, relief valve). Failure to install such relief devices properly could result in personal injury or damage to pump or property. GP does not assume any liability or responsibility for the operation of the user's high pressure system.



WARNING: This product can expose you to chemicals including lead, which is known to the state of California to cause cancer and birth defects or other reproductive harm. For more information, go to www.P65Warnings.ca.gov