



Pneumatically-Operated Pressure Regulator

FEATURES

- Available in 2 versions according to pressure and volume required.
- Allows remote control of the water pressure.
- Allows off-load start up.
- When there is no air pressure water flows through the by-pass without pressure.
- No discharge leakage in bypass.
- Suitable for controlling several units at the same time,



SPECIFICATIONS

Part Number	PN4-200	PN4-300
Max Volume	132 GPM	103 GPM
Max pressure	2,900 PSI	4,300 PSI
Max Fluid Temperature	140° F	
Inlet Port Thread	1-1/2" BSP-F	
Discharge Port Thread	1-1/2" BSP-F	
Bypass Port	1-1/2" BSP-F	
Air Inlet Port	1/4" BSP-F	
Max Air Pressure	101 PSI	
Air Consumption	28 n/liter/min	
Oil Capacity - oz / (liters)	8.5 / (.25) Hydraulic	
Weight	35.3 LBS	
Materials	Upper Body:	Aluminum Alloy
	Lower Body:	SPF600 Cast Iron
Valve & Seat Valve:	Stellite® Coated AISI 420 SS	

Specifications are subject to change without notice.

INSTALLATION DIAGRAMS

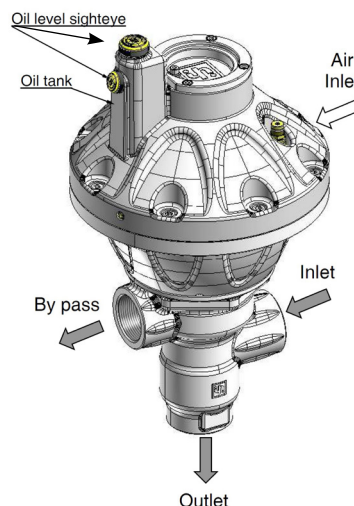

INDUSTRIAL

INDUSTRIAL



General Pump
is a member of
the Interpump Group



DIMENSIONS & INFORMATION

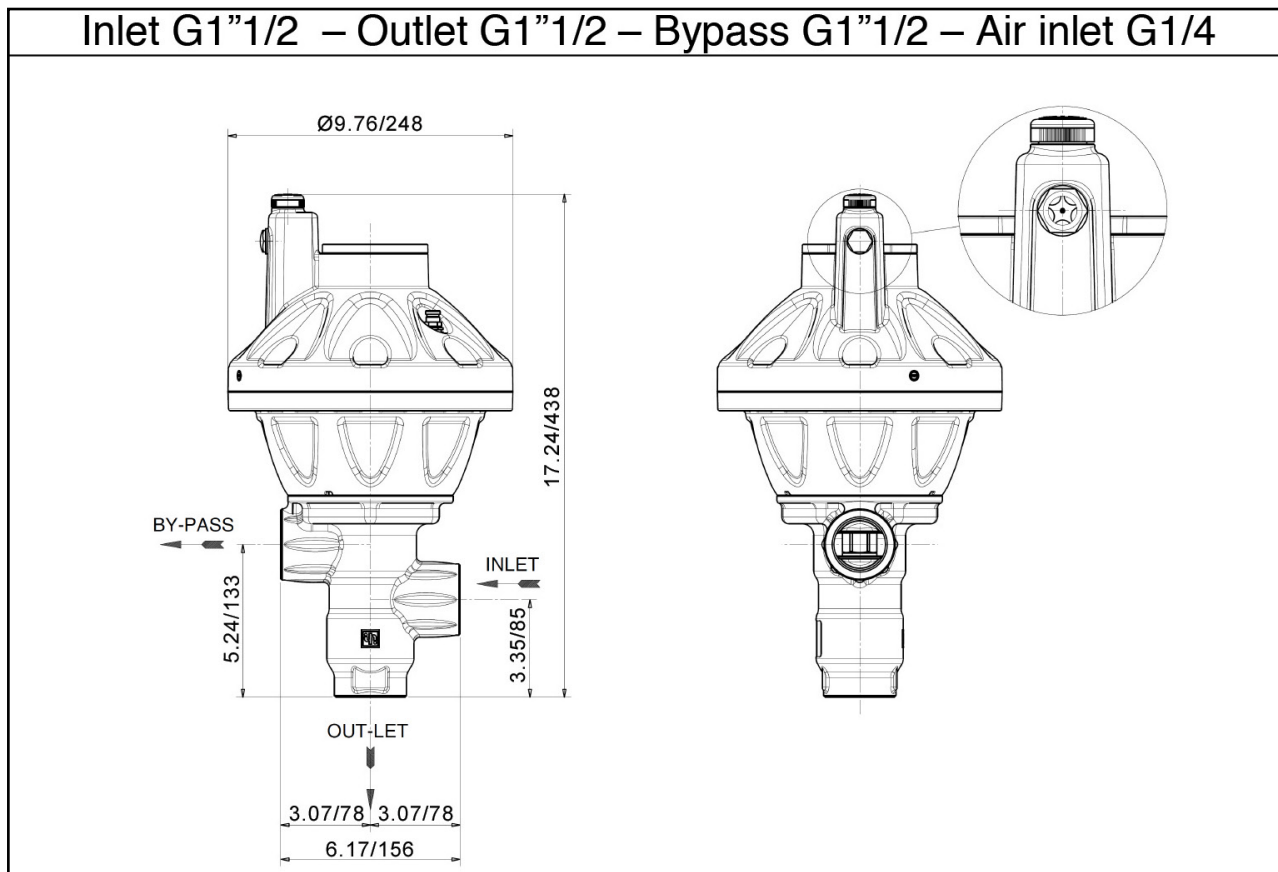

Horizontal Installation

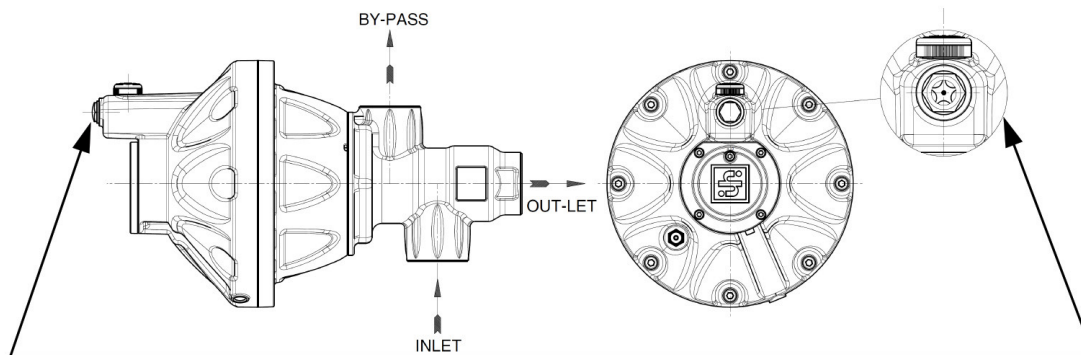

WARNING: In horizontal installation, the parts pos. 15 - G3/8 RELIEF PLUG and pos. 17 - G 3/8 OIL PEEPHOLE shall be inverted. **Important:** the tank must always be oriented upwards. Make sure that the oil level is half the peephole.

WARNING: For other installation methods please contact GP's Customer Service.

PARTS LIST

No.	Part No.	Description	Qty.
1	F99153700	Screw, TCEI M5 x 12	10
2*	F96687500	Washer, Ø5 x 9 x 1.5	4
3	F36015122	Cover	4
4	F99367100	Screw, TECi M10 x 25	1
5*	F90446000	O-ring Ø56.52 x 5.34	1
6	F36015062	Piston	1
7*	F36014655	Valve Seat Piston	1
8*	F36014555	Valve Plate	1
9*	F94730750	Spring, Ø0.4 x 11	1
10	F36016555	Spring Guide	1
11	F96692000	Washer, Ø5.5 x 20 x 1.5	4
12*	F90386100	O-ring, Ø26.65 x 2.62	2
13*	F90403500	O-ring, Ø15.47 x 3.53	2
14	F36016460	Guide Bushing	1
15	F98210400	Sight Glass	1
16	F36016600	Nozzle Oil Tank	1
17	F97593000	Sight Glass	1
18	F36015222	Upper Body	1
19	F99308400	Screw, TCEI Ø8 x 30	8
20	F98642000	Jet, Ø0.40	1
21	F36349371	Closing Plug	1
22*	F90407700	O-ring, Ø44.45 x 3.53	1
23	F94746000	Spring, Ø0.69 x 80	1
24	F99372000	Screw, TCEI M10 x 25	6
25	F36015322	Lower Body	1
26	F92222300	Nut, M8-8	8
27*	F90445000	O-ring, Ø43.82 x 5.34	1
28	F36015756	Jacket	1
29*	F90398000	O-ring, Ø59 x 3	1
30	F36015805	Intermediate Ring	1
	F36015956	Valve Seat, PN4-200	1
31	F36016056	Valve Seat, PN4-300	1
32*	F90523000	Spiralback Ring, 40.8 x 46 x 1.5	1
33*	F90397300	O-ring, Ø40 x 3	1
34	F97675000	Spiral Pin	1
35	F36015405	Valve Body, LP	1
	F98274150	Plate, PN4-200	1
36	F98274250	Plate, PN4-300	1
37	F92237400	Nut, M10	1
38	F96712100	Washer, Ø10.5 x 21 x 2	2
39	F96729500	Washer, Ø14 x 38 x 4, INOX	2
40*	F36014882	Closing Plate	1
41	F36016256	Primary Control Rod	1
42	F36014907	Valve Tab	1
43*	F90382500	O-ring, Ø10.78 x 2.62	1
44*	F90520400	Spiralback Ring, 38 x 11.26 x 1.3	2
45*	F90406500	O-ring, Ø37.69 x 3.53	1
46	F36016370	Piston	1
47	F92202100	Nut, M6	6
48	F96735800	Washer, Ø16.2 x 80 x 4	1
49	F36014022	Membrane Support	1
50	F36014148	Membrane	1
51	F36013976	Membrane Plate	1
52	F99185200	Screw, M6 x 16	6
53*	F90384700	O-ring, Ø20.24 x 2.62	1
54	F36015656	Control Rod	1
55	F98872000	Safety Valve	1
56	F98643000	Jet, Ø0.70	1
57*	F90412500	O-ring, Ø71.44 x 3.53	1
58	F97666200	Spiral Pin	2
*	F0303	Repair Kit	

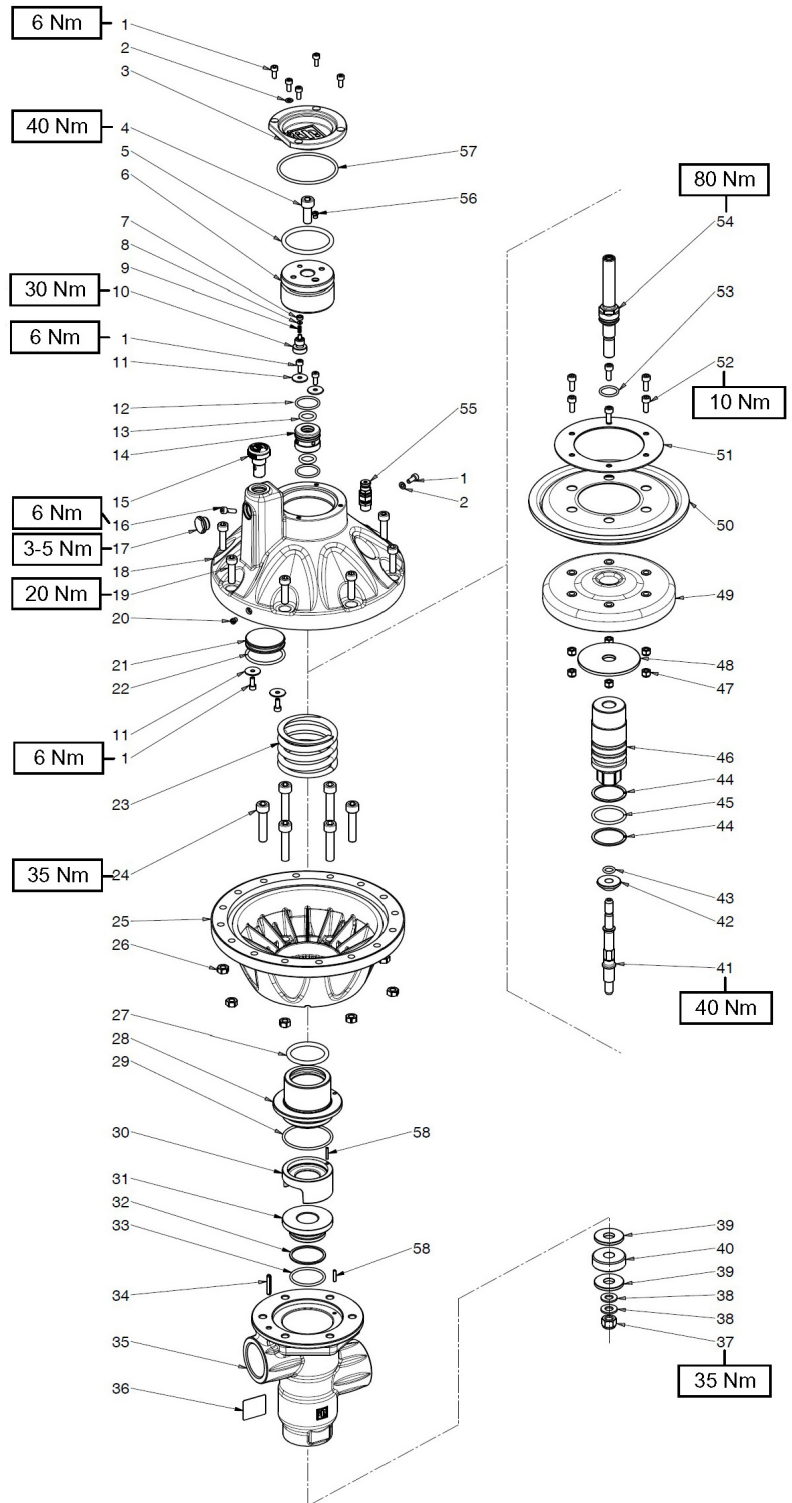

INFORMATION

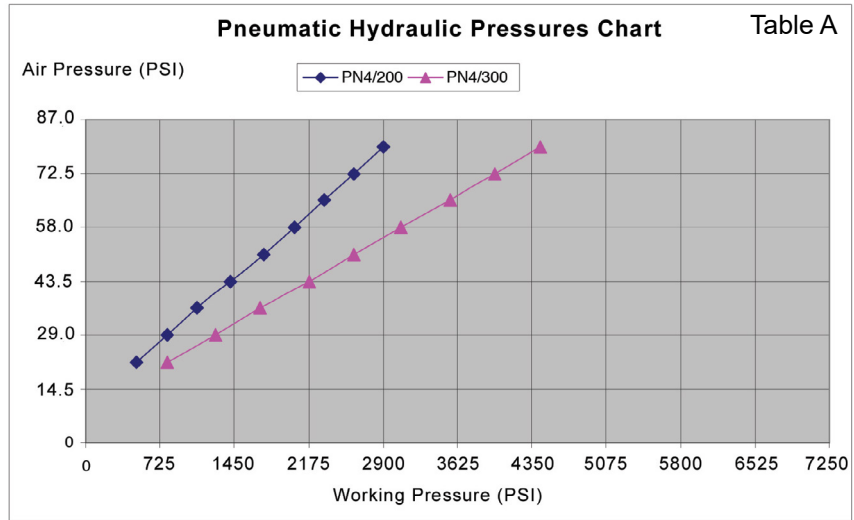

At the pneumatic pressure of 0.58 MPa the air consumption is 28 NI/min.

Air Valve Diagram

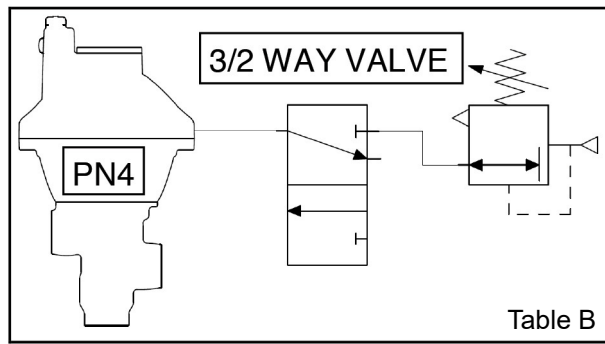

Valve Use Field Graph

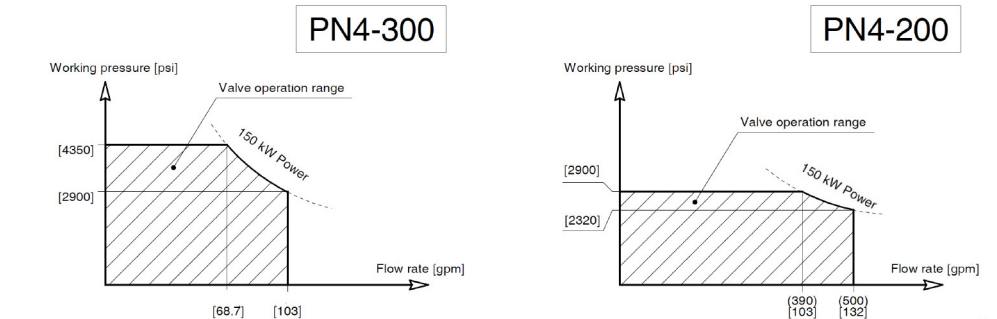

INSTALLATION AND INSTRUCTIONS FOR USE

THIS DOCUMENT PROVIDES THE INSTRUCTIONS FOR THE INSTALLATION, USE AND MAINTENANCE OF THE VALVE, THEREFORE IT IS AN INTEGRAL PART OF THE VALVE ITSELF AND MUST BE READ CAREFULLY BEFORE ANY USE AND KEPT WITH CARE.

STRICTLY COMPLY WITH THE INSTRUCTIONS CONTAINED IN THIS DOCUMENT IN VIEW OF A SAFE AND EFFECTIVE USE OF THE VALVE.

FAILURE TO COMPLY WITH THESE INSTRUCTIONS MIGHT CAUSE EARLY FAULTS AND RESULT IN SITUATIONS OF DANGER, IN ADDITION TO VOIDING ANY WARRANTY.

1. GENERAL INFORMATION

1.1 The **PN4** pressure regulator is a manually adjustable, pressure-operated pneumatic-control device, which, according to its setting, limits the pumps/system pressure by conveying the excess of water to the by-pass. Moreover, when the outlet flow is blocked, this device totally releases the flow, thus keeping the pump/system at the adjusted pressure.

1.2- The pneumatic control of the valve allows to change the hydraulic working pressure by changing the air pressure. The two pressures are proportional, i.e. when increasing the pneumatic pressure the hydraulic pressure increases and when reducing the pneumatic pressure the hydraulic pressure decreases (see table A).

1.3- The pneumatic control of the valve allows it to cut in or to cut out the adjusted hydraulic pressure. This function is particularly suited for automatic working cycles and remote controls. When the pneumatic pressure is cut out, the pump starts at zero pressure, i.e. without the motor being under stress.

1.4- In order to operate the pneumatic control of the valve it is necessary to use compressed air with a value depending on the desired hydraulic pressure. In order to correctly operate the pneumatic control we suggest you use a 3/2-way valve and a pressure regulator as shown in the diagram (table B).

1.5- Since the valve is used in connection with a high pressure water pump/system, which shall be called hereafter only "system", installation and use must be suited to the type of system used and comply with the safety Regulations in the Country where the valve is used.

1.6 Before installing and using the valve for the first time, we suggest you check that it is undamaged and make sure that the rated features correspond to the required ones. If this is not the case, do not use the valve and contact the GP's Customer Service Department.

1.7 Before using the valve, make sure that the system the valve is used with is certified to comply with the relevant Directives and/or Regulations.

1.8- In order to install the valve correctly, follow the instructions for the water inlet, outlet and by-pass connections, as stated in this instruction manual and/or on the valve itself.

2- PACKAGE AND HANDLING

2.1- Packages must be handled in compliance with the instructions stated on the packages themselves and/or provided by the manufacturer.

2.2- In case the valve is not used immediately, it must be stored in its original packaging and placed in areas which are not exposed to the weather and are protected from excessive humidity and direct sunlight. It is advisable to place wooden pallets or other types of pallets between the package and the floor, in order to prevent the direct contact with the ground.

2.3- The package components must be disposed of in compliance with the relevant laws in force.

2.4- Take great care when lifting and handling the valve during installation and avoid any sudden accelerations or changes of direction. Also avoid any excessive oscillations and keep the valve upright in order to prevent any loss of stability and the possibility of overturns.

2.5- To lift the valve, use tools such as snap-hooks, straps, ropes, hooks etc., which must be certified and suited for the mass to be lifted. The valve mass is stated in the table of technical features.

3- INSTRUCTIONS FOR PRESSURE SETTING:

3.1- In order to obtain a correct adjustment and a proper functioning of the valve, always make sure that, when working at the maximum pressure, the valve by-pass keeps releasing a quantity of water equal to 5% of the total flow-rate. In case the flow-rate at the by-pass is close to zero or exceeds 15% of the maximum flow-rate, this could cause faults, early wear and result in situations of danger.

The positions mentioned in the following instructions refer to those shown in the Parts List and Exploded View

3.2- Connect the valve to the water system and to the pneumatic circuit and set it upright or horizontal (for other positions please contact the GP's Customer Service Department), then follow these steps:

3.2.1- Open the pneumatic pressure regulator completely in order to control the valve.

3.2.2- Start the hydraulic system on which the valve is fitted and make sure that the air contained in it is fully ejected.

3.2.3- Open the gun or the water control device. Start the pneumatic circuit and begin adjusting the air pressure within the valve by using the pneumatic pressure regulator. Alternate the adjusting operations with a few openings and closings of the gun or of the control device. When the desired hydraulic pressure has been reached, open and close the gun/control device a few times again in order to stabilize the various components (seals, springs etc.). Check the pressure value again and correct if necessary.

3.2.4- In case you decide to change the adjusted hydraulic pressure later, follow the procedure stated in paragraph 3.2.3 again.

3.2.5- The upper body pos. 18 is equipped with a safety valve pos. 55 in order to limit the pneumatic pressure within the valve and with a permanently open breather nozzle pos. 20 in order to regulate the functioning (air consumption). The installer must adjust the safety valve so that it opens when the pneumatic pressure is approx. 10% higher than the pneumatic pressure necessary to obtain the maximum desired hydraulic pressure.

INSTALLATION AND INSTRUCTIONS FOR USE

3.2.6- The maximum pneumatic pressure allowed within the valve must not exceed 101.5 PSI (0.7 MPa).



In case of doubts, do not hesitate to contact GP's Customer Service Department. IMPORTANT: During use, never exceed the maximum values of pressure (of water and air), flow-rate and temperature as stated in this document and/or indicated on the valve.

4- WARNINGS

4.1- The installation and the setting of the maximum pressure must be made by qualified staff only, who must have the required skills to handle high pressure systems and be informed of the operating and safety instructions contained in this document.

4.2- The installer must provide the consumer with the proper instructions for the correct use of the system the valve is used in connection with.

4.3- Use soft and filtered water only. In case of salt water and/or of water containing solid particles of a size exceeding 360µm, the internal components of the valve will be subject to quick wear; furthermore, this might compromise the correct functioning of the valve. Addition agents can be used in the water, provided that they are delicate, biodegradable and always complying with the Regulations in force in the Country where the valve is used.



4.4- In the systems for hot water production, the temperature of the liquid that comes into contact with the valve must always be lower than the value stated in this instruction manual and/or indicated on the valve itself. **Avoid the formation of steam or overheated water.**



IMPORTANT: When the temperature of the liquid is close to the maximum value, the outside temperature of the valve body is only slightly inferior. Therefore, take care not to contact the hot surfaces.

4.5- After use and/or before performing any operation on the system or on the valve, release the pressure by using the adjustment knob/screw and opening the gun or the control device for a few seconds. The jet created by the residual pressure must be directed downwards in order to avoid damages or dangers.

4.7- To connect the valve to the system it is preferable to use flexible hoses fitted in a way that they do not form 90° elbows, throttlings or siphons which could include harmful air bubbles. **The inside diameters of the hoses and fittings must be equal to the correspondent inside diameters of the inlet, by-pass and outlet threads of the valve.** Moreover, it is necessary to correctly choose the type of hose depending on the rated pressure and flow-rate; the hoses must always be used within their operation limits as stated by the manufacturer and indicated on the hoses themselves.

4.8- Tighten the G1"1/2 inlet, outlet and by-pass fittings of the valve torque wrench setting 398.3 ±5%(540 Nm).

In order to ensure the seal, fit a metal washer with a rubber ring between the fittings, or use a proper sealant on the thread.

WARNING: Use parallel threads only (not tapered threads). The threads must comply with the working pressures and the rated torque wrench settings with reference to their material and shape.

4.9- Always connect the valve by-pass fitting to a hose, in order to avoid the excessive noise caused by the water outflow through the by-pass without hose.

4.10- Before operating the system, it is advisable to start it for a preliminary test run in order to check that the system is properly installed.

4.11- **Warning:** If the valve is used at a low temperature involving the risk of frost, make sure that there is no ice formation inside and/or that the valve is not blocked before using it.

4.12- In order to optimize the pump-valve coupling, it is necessary to keep the valve operation range, as a function of the pump pressure and flow rate, within a maximum power of 204 (150 kW).

- **PN4-200** this means using pumps producing a flow rate of approx. 103 GPM (390 l/min) for maximum working pressures of 2900 PSI (20 MPa - 200 bar), and generating a pressure of approx. 2320 PSI (16 MPa - 160 bar) for maximum flow rates of 132 GPM (500 l/min).

- **PN4-300** this means using pumps producing a flow rate of approx. 68.7 GPM (260 l/min) for maximum working pressures of 4350 PSI (30 MPa - 300 bar), and generating a pressure of approx. 2900 PSI (20 MPa - 200 bar) for maximum flow rates of 103 GPM (390 l/min).

5- MAINTENANCE

5.1- Maintenance and repair must be carried out by qualified and authorized staff only. Before any operation, make sure that the valve and the system are shut down and made unusable.

5.2- A correct maintenance helps extend the working life and grants a better performance of the valve.

5.3- From time to time, check the oil window pos. 4 to verify the oil level. If necessary, add the oil by the cap pos. 1 up to the middle of the oil window.

5.4- From time to time, it is necessary to check that the valve is clean outside, and that there is no sign of oil or water leakage and/or malfunctioning. If necessary, replace the involved parts. In case of doubts, contact GP's Customer Service Department.

5.5- Replace the valve parts with original spare parts only. Use only oil types as stated below.



IMPORTANT: After maintenance, make sure that the valve is re-assembled correctly and that the initial conditions are restored. Comply with the torque wrench setting values and set the pressure again as described above.

5.6- The valve contains approx. 0.25 liters of high-viscosity hydraulic oil (cSt 40°C=44.2) containing addition agents used to grant higher performances, with an excellent level of protection against wear and high oxidation and corrosion strength. It is possible to use other oils having similar features provided that they are VG 46 DIN 51519 ISO quality (or with 15W-20 SAE degree).

INSTALLATION AND INSTRUCTIONS FOR USE

5.7- The exhausted oil must be gathered in containers and disposed of at an authorized center as established by the laws in your area. The oil must not be dispersed in the environment for any reason.

5.8- In case of disposal, we suggest you take the valve to an authorized disposal center or contact GP's Customer Service Department.



IMPORTANT: The valve shall not be tampered with for any reason and/or used for any purpose other than the use it has been designed for. In case of tampering, the manufacturer disclaims all responsibility as to the valve functioning and safety.

6- WARRANTY CONDITIONS

6.1- The period and conditions of warranty are specified in the purchase contract.

6.2- Warranty is voided in case the valve is used for improper purposes, used at higher performances than the rating, repaired with non-original spare parts or if it turns out to be damaged due to the non-compliance with the operating instructions or to unauthorized tampering.