

GENERAL PUMP *A member of the Interpump Group*

PLSR4LVNCV / PLSR4HVNCV

Unloader Valve with No Check Valve



Trapped pressure type unloader - ideal for use in systems which incorporate a gasoline engine; eliminates back pressure in system when pulling a manual start engine. Features brass and stainless steel construction, and a plastic adjustable pressure control knob.

General Pump recommends using a safety relief device in conjunction with this unloader valve when installed on a positive displacement pump. General Pump is not liable and assumes no responsibility for this valve when used in a customer's high pressure system.

SPECIFICATIONS

Part Number:	PLSR4LVNCV (White Spring)	PLSR4HVNCV (Blue Spring)
Max. Volume:	10.5 GPM	
Max. Pressure:	<i>PLSR4LVNCV</i>	2,600 PSI
	<i>PLSR4HVNCV</i>	4,050 PSI
Max Temperature	194° F	
Port Sizes: Inlet	(2) 3/8" NPT-F	
Outlet	3/8" NPT-F	
Bypass	3/8" NPT-F	
Overall Dimensions	7.12" x 3.2" x 2.3"	
Weight	1.60 lbs.	
Materials	Brass, Stainless Steel, Viton	

PARTS LIST

No.	Part No.	Description	Qty
1	Y60014551	Piston, SS	1
2	Y60013635	Housing, 3/8" NPT-F, Brass	1
3	Y10305810	O-ring, 1.78 x 10.82 mm	1
4	Y60025451	Seat, SS & O-ring	1
5	Y14746100	Ball, 13/32" SS	1
6	Y60041051	Spring, 1.6 x 11.5 x 20 mm, SS	1
7	Y10306410	O-ring, 1.78 x 14	1
8	Y60013731	Suction Coupler, 3/8F NPT	1
9	Y10400601	Back-up Ring, 6.2 x 9 x 1.2 mm	1
10	Y10305100	O-ring, 1.78 x 6.07	1
11	Y14405800	Back-up Ring	1
12	Y10305910	O-ring, 1.78 x 11.1 mm	1
13	Y10306610	O-ring, 1.78 x 15.6 mm	1
14	Y60181731	Nipple, 3/8" NPT-F	1
15	Y60014384	Cap, Knob	1
16	Y11458910	Hex Locknut, M8	1
17	Y60000131	Seat, Knob	1
18	Y60014484	Knob	1
19	Y14372040	Washer, 9.2 x 24 x 0.5 mm	1
20	Y60001261	Spring, 5 x 25 x 50 mm White	1
	Y60003361	Spring, 5.7 x 26 x 53 mm Blue	1
21	Y11457331	Hex Nut, M8, Brass	2
22	Y60014631	Piston Holder, Brass	1
23	Y10306410	O-ring, 1.78 x 14	1
*	Y60012824	Repair Kit	

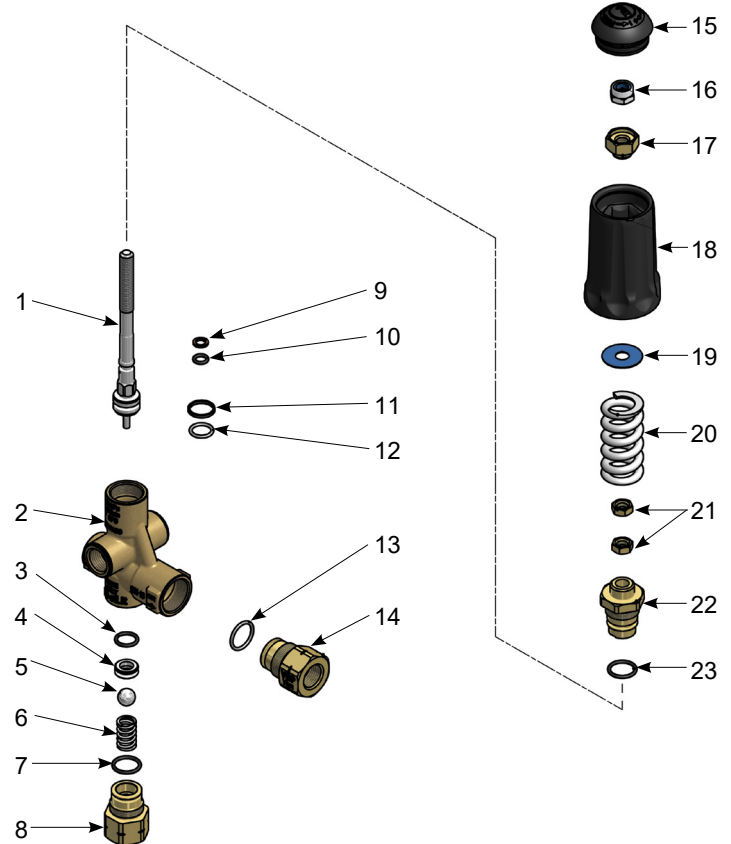

DIMENSIONS

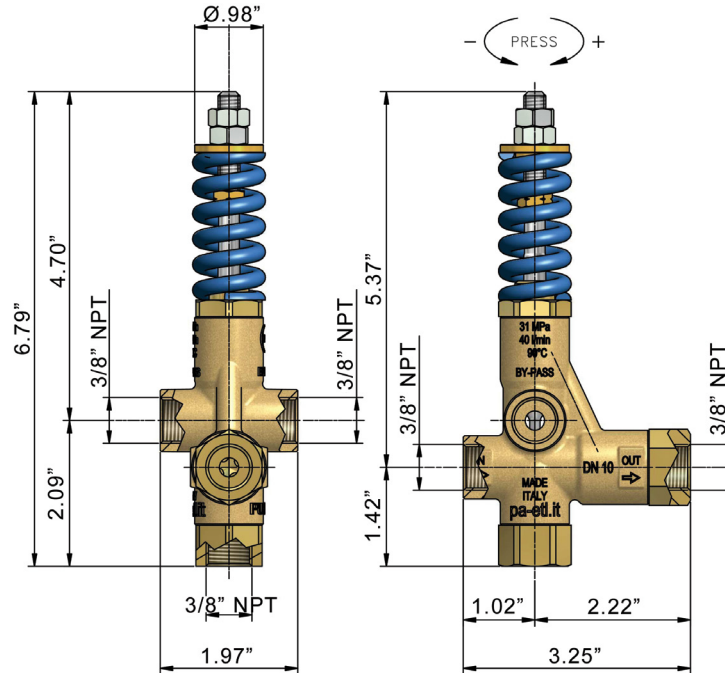

SELECTION AND OPERATION

SELECTION

This product is intended to be incorporated on a finished machine. This product is to be used with clean fresh water, for use involving different or corrosive liquids, contact the GP Customer Service Department. Appropriate filtration should be installed when using impure liquids. Choose the valve appropriate to the working data of the pump (permissible pressure, flow and rated temperature of the system). The pressure of the pump must not exceed the maximum pressure of the valve.

OPERATION

The valve regulates the maximum pressure of the system by varying the flow discharged by the bypass. The adjustment is made by altering, by means of a piston, the position of a sphere which partially closes the bypass opening. The valve is sensitive to water flow. At gun opening, the water flows through the valve which maintains the system in pressure until the gun closes, the interruption of the flow provokes the complete aperture of the bypass which allows to discharge the flow at low pressure. At gun closure, the special mechanism of zero setting, which does not include a check valve, keeps in connection the delivery line and the bypass line, in that way permitting to lower the pressure all around the system and not only in the source line of the valve.

INSTALLATION

This valve, on a system that produces hot water, must be fitted upstream from the source of heat. On a system that generates hot water, it is advisable to use accessories that limit the accidental increase of fluid temperature. **Always install a safety valve.** We recommend the use of a nozzle with flow rate which allows a regular discharge from the valve bypass of at least 5% of the flow supplied by the pump. In order to achieve a constant pressure and easy adjustment. If the nozzle wears out, the pressure decreases. To reset pressure back to working level, it is necessary to replace the worn nozzle. When a new nozzle is fitted, resetting of the system to its original working pressure is required.

DISCHARGE SYSTEM AND WATER ADDUCTION

The bypass discharge can be sent back to the pump intake or returned into a tank; in such cases it is advisable that the tank be fitted with baffles to reduce eventual turbulence and air bubbles which could be harmful to the pump.

PRESSURE ADJUSTMENT/CALIBRATION

The desired working pressure must be adjusted with the system running and the gun opened. Adjust the pressure by screwing or unscrewing the adjustment screw. The operation is easier if the correct nozzle has been chosen (see above). When screwing the adjustment screw a consequent pressure increase must be matched. If, before reaching the desired pressure, there is no pressure increase, DO NOT FORCE. Rather, check the correct ratio of nozzle/flow rate - pressure and, if necessary, replace with a smaller size nozzle.

ATTENTION: the nut in position 23 is a mechanical security device that limits the maximum pressure; it must absolutely NOT be removed.

MAINTENANCE

STANDARD: every 400 working hours, check and lubricate the seals with water resistant grease.

SPECIAL: every 800 working hours, check the wear of the seals and internal parts and, if necessary, replace with original GP parts taking care, during installation, to lubricate with water resistant grease.

The manufacturer is not to be considered responsible for damage as a result from incorrect fitting and maintenance.

TROUBLESHOOTING

PROBLEMS	PROBABLE CAUSES	SOLUTIONS
Frequent valve recycles	Damaged check valve O-ring Leaking connections Restricted bypass or too small diameter of the bypass hose	Replace Check or renew Clean or adapt passage diameter
Valve does not reach pressure	Piston O-rings worn out Debris between seat and shutter Seat worn out Nozzle worn out Incorrect choice of nozzle	Replace Clean the seat Replace Replace Fit with smaller nozzle
High pressure peaks at gun closure	There is not a minimum of 5% of total flow discharged in bypass Excessive flow in bypass Adjustment with spring totally compressed	Reset Correctly Change type of valve or adjust passages Loosen adjustment screw and eventually fit with smaller nozzle
Valve does not discharge at low pressure at gun closure	Jammed check valve Debris on check valve	Clean or replace Clean