

FEATURES

- Symmetrical power end design featuring top and bottom mounting holes allowing for easy left to right conversions
- Solid Ceramic plungers
- High volumetric efficiency suction/delivery valve
- SAE-B hydraulic drive available
- Nickel-plated forged brass manifold
- Heavy-duty tapered roller bearings
- Low/High pressure packing design with integrated cooling system
- Ideal for use in car wash and other high pressure cleaning applications
- Also available with high temp seals

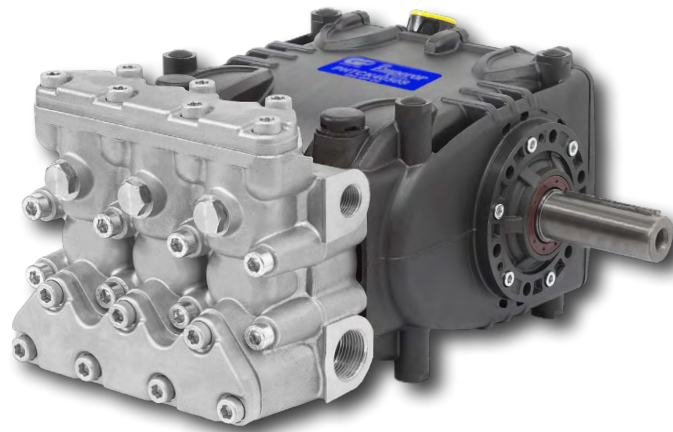

SPECIFICATIONS

Pump Model	PHTCK3623S		
Maximum Volume	18.0 GPM	21.0 GPM	25.0 GPM
Maximum Pressure	1500 PSI		1300 PSI
Maximum RPM	1000 RPM	1150 RPM	1350 RPM
Horsepower	18.5 HP	22.0 HP	22.3 HP
Maximum Inlet Pressure	40 PSI		
Maximum Fluid Temperature	140°F		
Bore (in / mm)	1.4 in./36mm		
Stroke (in / mm)	.9 in./ 23 mm		
Oil Capacity	64.2 oz. - Use GP 220 Series Oil		
Inlet Port Thread	1" NPT-F		
Discharge Port Thread	1/2" NPT-F		
Shaft Diameter	1.181 in./30 mm		
Weight	79.6 lbs.		
Dimensions - Nominal	15.3" x 13.4" x 7.7"		

TRIPLEX

TRIPLEX



General Pump is a
Member of
The Interpump Group



Instructions and Recommendations for the Installation

Maximum temperature of the water through the pump is 140°F (60°C).

In order to obtain maximum performance in terms of duration of seals and valves, it is necessary to respect a few simple rules, as follows:

1) **In order to avoid damage caused by cavitation, the pump must be pressure fed.**

2) **The plumbing which feeds the pump must be of a diameter at least equal to the inlet port.**

Also, follow the suggestions below:

a) Make the plumbing as short and straight as possible, preferably in an upward direction to facilitate the expulsion of eventual air bubbles naturally if compatible with the requirements of the system.

b) It is always useful to put a filter at the inlet with capacity of 4 to 5 times flow of the pump, for example for a 4 GPM (15 l/min) pump, put a filter from 160 to 20 GPM (60-75 l/min) The mesh size suitable for this application is 0.016" (.4 mm).

c) It is extremely important to put a pressure switch on the inlet port of the pump, and in any case downstream from the filter, so that it can stop the pump should the feed pressure drop by 20% due to the filter clogging or failure of the feed pump, etc.

3) Change of oil

We recommend the **first oil change after the first 50 hours**, with the **pump stopped** and the **oil still warm**.

This change is not recommended because the oil has lost its properties, but rather to eliminate the impurities that have gotten into the oil during the running-in phase. If these impurities are not removed, but are allowed to remain in the oil, they *may cause premature wear* to the moving parts and the oil seals. **After this initial change, the oil can then be changed every three months or 300 hours of operation thereafter.**

Please note: If the pump works in conditions with high humidity and with sharp temperature changes, it is possible that condensation will appear inside the crankcase, which mixing with the oil can change its properties. This is easy to see because the oil changes to a white, milky color.

If the pump does not have excessive water leaking from the packings, and the oil becomes milky, the oil has to be changed more frequently. The percentage of water in the oil must not exceed 20%.

Use oil per the following chart:

BRAND	TYPE
GENERAL PUMP	SERIES 220
BP	ENERGOL HLP 220
CASTROL	Hyspin VG220, Magna 220
MOBIL	DTE OIL BB
SHELL	TELLUS C 220
TOTAL	CORTIS 220

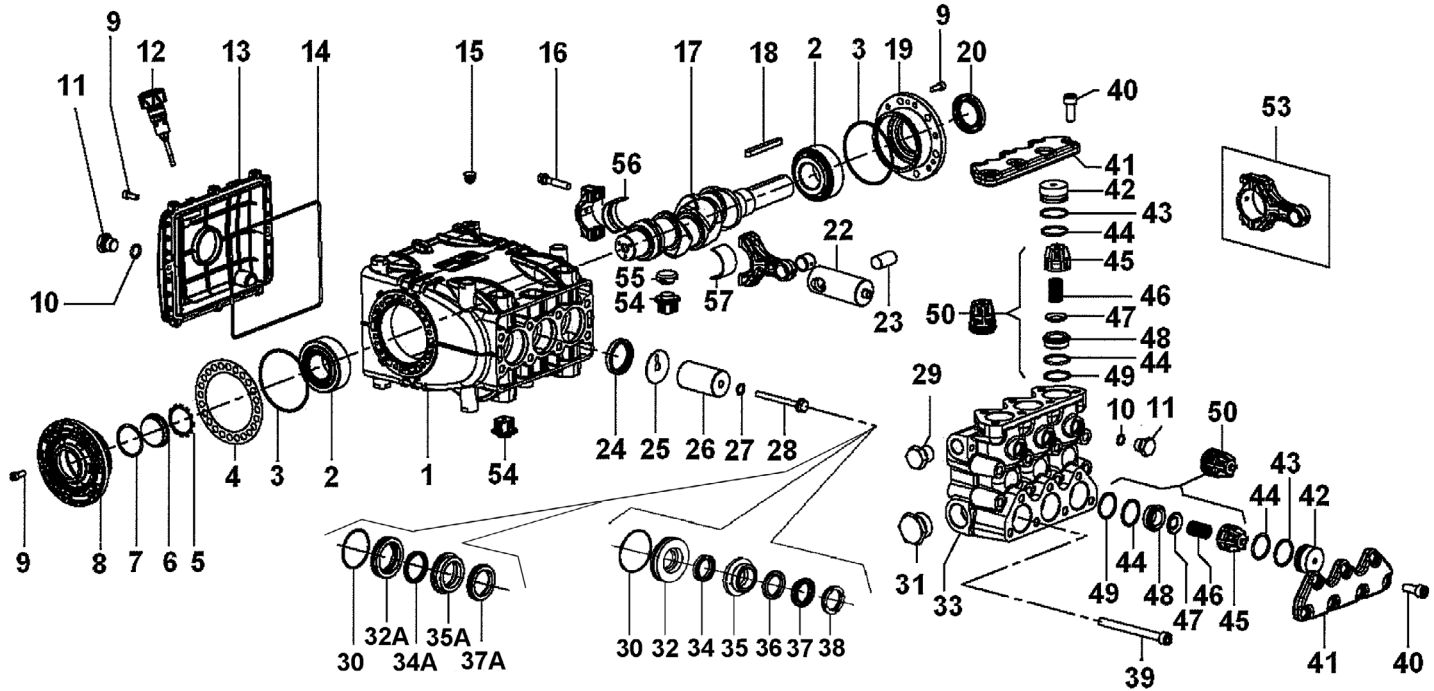

PARTS LIST

No.	Part No.	Description	Qty	No.	Part No.	Description	Qty	No.	Part No.	Description	Qty
1	70010022	Crankcase	1	20	90166800	Crankshaft Oil Seal	1	39	99381600	Screw, M10 x 110	8
2	91847700	Bearing, Tapered Roller	2	22	70050015	Plunger Guide	6	40	99367100	Screw, M10 x 25	14
3	F90391500	O-ring	2	23	97742000	Wrist Pin	3	41	70222341	Valve Colver	2
4	70220081	Shim, 0.1 mm	1	24	90167700	Plunger Rod Oil Seal	3	42	70211670	Plug	6
	70220381	Shim, 0.25 mm	1	25	96709900	Fliinger Washer	3	43	90518000	Anti-extrusion Ring	6
5	90075600	Retainer	1	26	70040509	Plunger, 36 mm	3	44	90386500	O-ring	12
6	70211801	Oil Level Indicator	1	27	90358400	O-ring	3	45	36204751	Valve Guide	6
7	90387700	O-ring	1	28	70224111	Plunger Bolt	3	46	94745000	Valve Spring	6
8	70150122	Side Cover, Sight Glass	1	29	638294	Plug, 1/2" NPT, SS Opt.	1	47	36201076	Valve Poppet	6
9	99185400	Screw M6 x 16	20	30	F90362600	O-ring, Ø50.52 x 1.78	3	48	36204866	Valve Seat	6
10	90383300	O-ring	4	31	638297	Plug, 1" NPT, SS Opt.	1	49	90517800	Anti-extrusion Ring	6
11	98209900	Plug, 3/8" G Nickel-plated	4	32	F70081270	Packing Retainer, Ø36	3	50	36714301	Valve Assy	6
12	98211550	Oil Dipstick	1	32A	F70080570	Packing Retainer, Ø36, High Temp	3	53	70030501	Connecting Rod Assy.	3
13	70160022	Crankcase Cover, Rear	1	33	70122441	Manifold, Nickel-plated, 36mm, NPT	1	54	70222551	Plug, Crankcase	6
14	90394200	O-ring	1	34	F90279800	L.P. Packing, Ø36	3	55	71225951	Plug Cover, Crankcase	3
15	98200500	Rubber Plug	7	34A	F90240000	L.P. Packing, Ø36, High Temp	3	56	90922300	Babbit, Back	3
16	99312300	Screw	6	35	F70222470	Middle Ring, Ø36	3		90922400	Babbit, Back +0.25	3
17	70020035	Crankcase	1	35A	F70216570	Middle Ring, Ø36, Hight Temp	3	90922500	Babbit, Back +0.50	3	
18	91490000	Key	1	36	F90281800	Restop Ring, Ø36	3	90922000	Babbit, Front	3	
19	70150022	Crankcase Cover, Open	1	37	90282000	H.P. Packings, Ø36	3	90922100	Babbit, Front +0.25	3	
				37A	90241000	H.P. Packings, Ø36, High Temp	3	90922200	Babbit, Front +0.50	3	
				38	F71100251	Front Ring, Ø36	3	HT125RCK	Rail Kit		

REPAIR KITS

KIT NO.	K2030 Valve Kit	High Temp Op.		F2133 Seal Kit	K2036 Complete Packing Kit	F2156 Babbit Kit	F2157 Babbit Kit +0.25	F2158 Babbit Kit +0.50
		K212 Seal Kit	K2032 Packing Kit					
ITEM NO'S INCLUDED IN KIT	44, 45, 46, 47, 48, 49 (50)	36, 38	34A, 35A, 36A, 37A, 38	30, 34, 36, 37	30, 32, 35, 36, 37, 38	56, 57	56, 57	56, 57
NUMBER OF ASSY'S IN KIT	6	3	1	3	3 kits needed for pump	3	3	3
NO. OF CYLINDERS KIT SERVICES	3	3	1	3		3	3	3

TORQUE SPECS*

Position	Ft.-Lbs.	Nm.
9	7.4	10
11	29.5	40
16	22.0	30
28**	14.7	20
29	88.5	120
31	73.7	100
39	29.5	40
40	59.0	80

*Decrease torque by 20% if threads are lubricated.

**Use Loctite 542.

DIMENSIONS

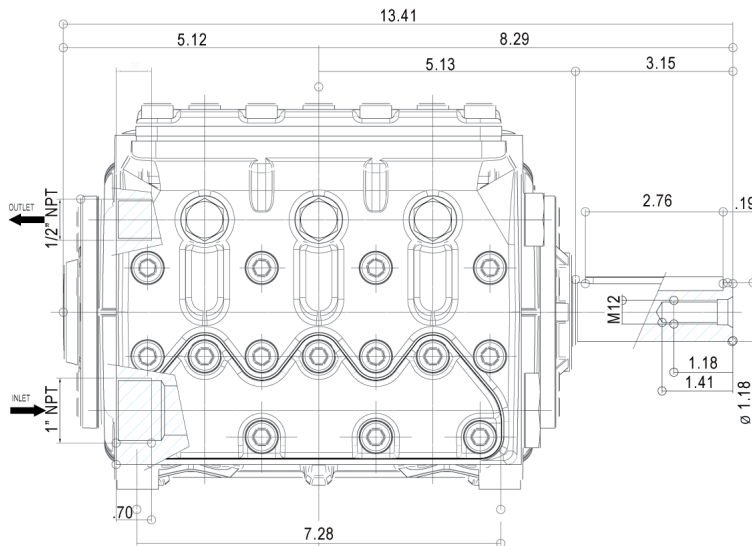
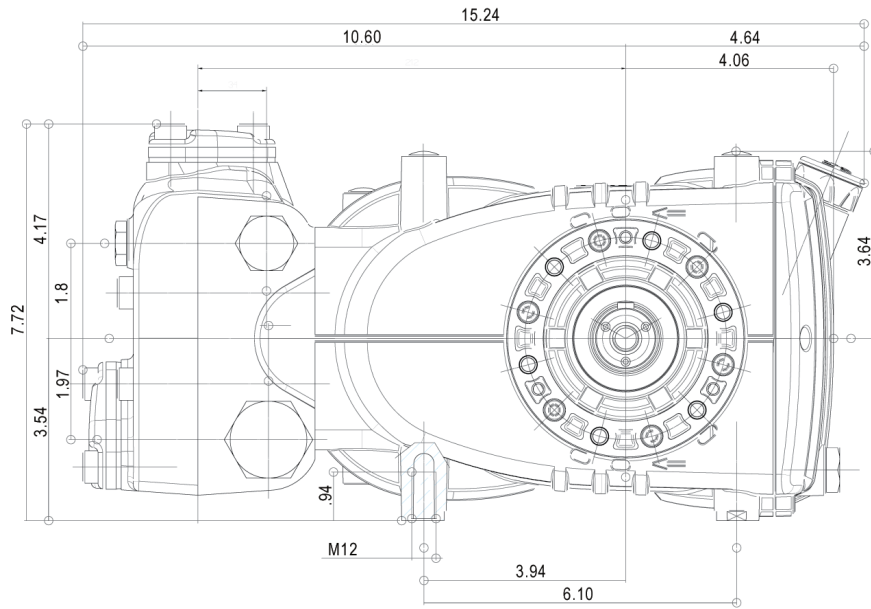

WARNING: High Pressure Systems require a primary pressure regulating device (i.e. regulator, unloader) and a secondary pressure relief device (i.e. pop-off valve, relief valve). Failure to install such relief devices properly could result in personal injury or damage to pump or property. GP does not assume any liability or responsibility for the operation of the user's high pressure system.



WARNING: This product can expose you to chemicals including lead, which is known to the state of California to cause cancer and birth defects or other reproductive harm. For more information, go to www.P65Warnings.ca.gov

