

GENERAL PUMP *A member of the Interpump Group*

ME Series 81

Maintenance Easy, Gas Engine Flange

FEATURES

- Each cylinder's packing stacks are housed in a removable seal cartridge.
- Manifold stays on pump while servicing seal cartridges, minimizes down time.
- "HR" anti-corrosion surface treatment on manifold is at least 30 times more corrosion resistant with salt water mist.
- "KC" Kevlar® compound high pressure seals for longevity under rigorous conditions.
- Oversized crankcase reduces oil temps.
- Oversized connecting rod and premium roller bearings.
- Solid ceramic plungers with innovative fastening system.
- Seal cartridge extractor tool included with pump.
- SAE J609-B flange for gasoline engine.



SPECIFICATIONS

Pump Model	ME11585G8	ME11595G8	ME11511G8
Max Volume	3.48 GPM	3.96 GPM	4.60 GPM
Max Discharge Pressure	3,045 PSI		
Max Pump Speed	3,400 RPM		
Max Inlet Pressure	125 PSI		
Max Inlet Vacuum	3 ft. Water (2.6 in. Hg)		
Bore	.591 in. / 15 mm		
Stroke	.335 in./8.5mm	.374 in./9.5 mm	.433 in./11 mm
Crankcase Oil Capacity	16.9 oz.		
Max Fluid Temperature	165° F		
Inlet Port Thread	3/8"-19 BSPP-F		
Discharge Port Thread	1/4"-19 BSPP-F		
Shaft Diameter	1" Hollow		
Weight	23.5 lbs.		
Dimensions	10.3" x 10" x 6.5"		

ME Series 81

GENERAL PUMP *A member of the Interpump Group*

DIMENSIONAL DRAWING

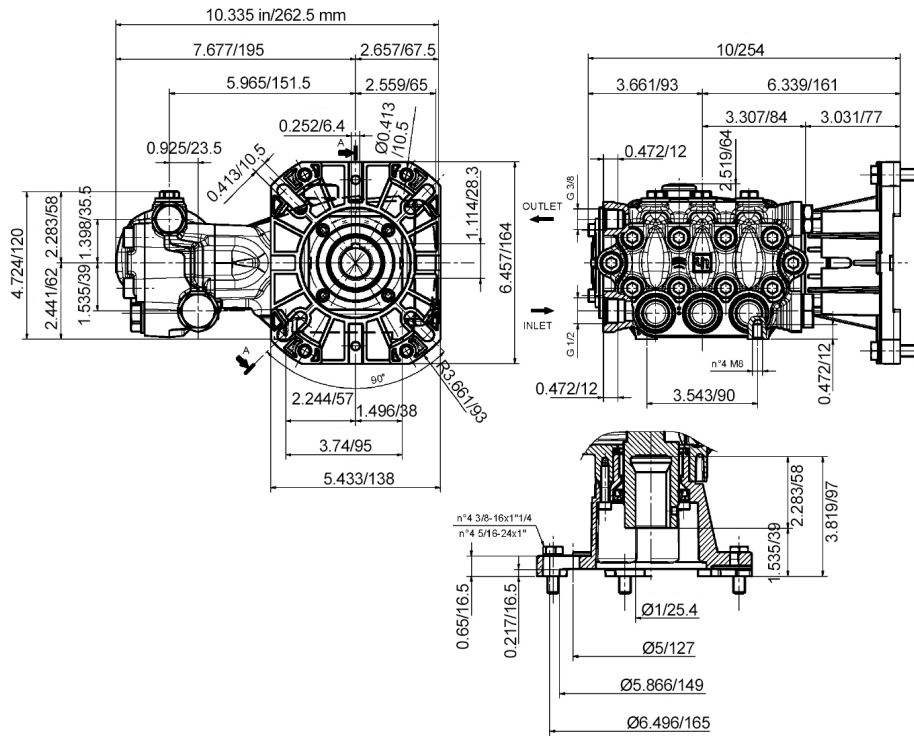

EXPLODED VIEW

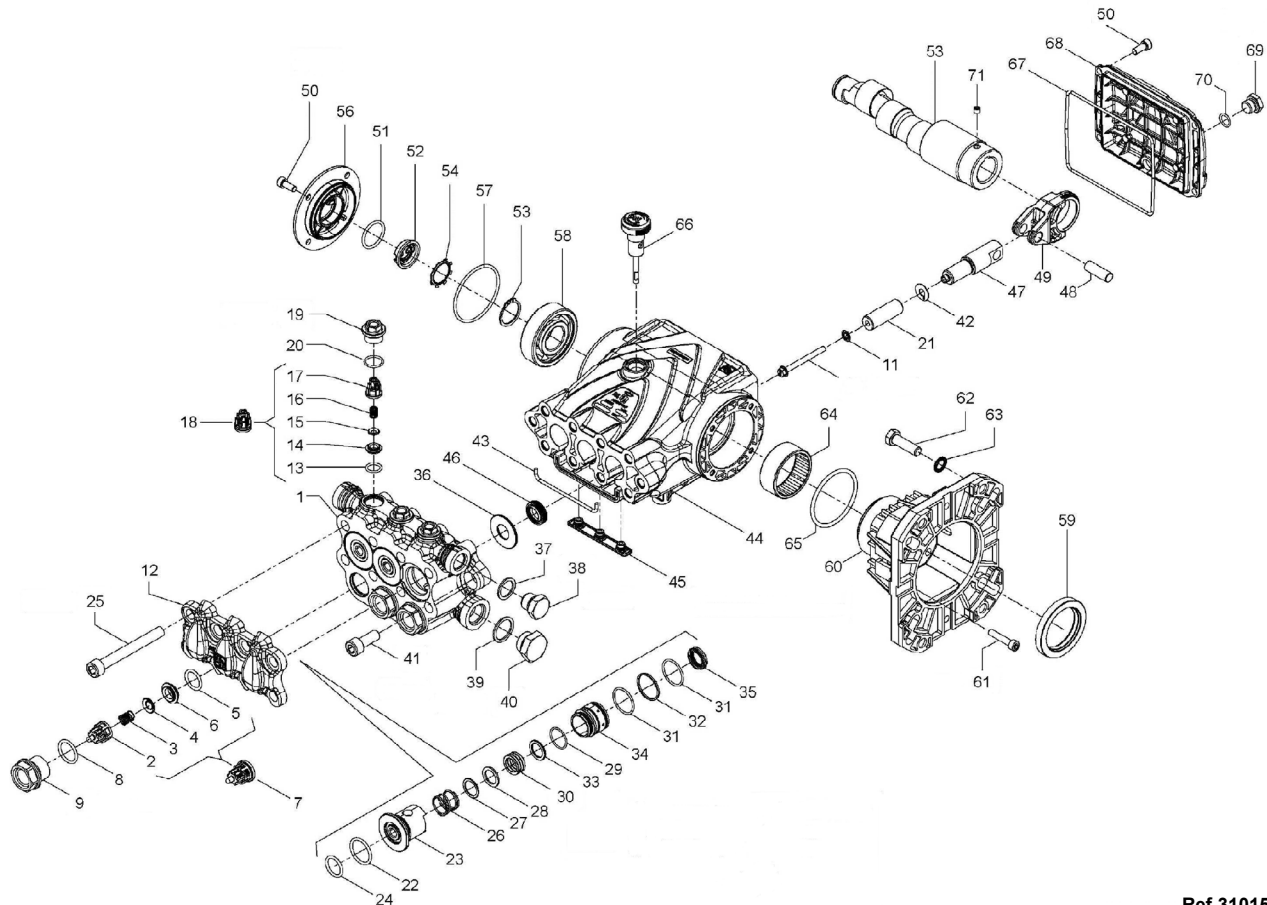

ME Series 81

GENERAL PUMP *A member of the Interpump Group*

PARTS LIST

No.	Part No.	Description	Qty.
1	81120015	Manifold Ø 15	1
2	36202551	Inlet Valve Guide	3
3	94737600	Inlet Spring, Ø9.4x14.8	3
4	36200176	Spherical Inlet Valve	3
5	90384100	O-ring, Ø17.13x2.62	3
6	36200366	Valve Seat	3
7	36711501	Inlet Valve Assy.	3
8	90384700	O-ring, Ø20.29x2.62	3
9	98222500	Plug, M24x1.5x16.7	3
10	99169000	Plunger Bolt	3
11	96690500	Washer Ø5.0x11.5x0.4	3
12	81210015	Front Cover	1
13	90367400	O-ring, Ø12x2	3
14	36211366	Vavle Seat Outlet	3
15	36211276	Poppet Outlet Valve	3
16	94733300	Outlet Spring	3
17	36211151	Valve Guide	3
18	36719301	Outlet Valve Assy.	3
19	98213750	Valve Cap	3
20	90359300	O-ring Ø15.6x1.78	3
21	58040109	Plunger Ø15x42	3
22	90385800	O-ring, Ø23.81x2.62, Ø15	3
23	81210870	Cartridge Bushing, KC, Ø15	3
24	90384300	O-ring, Ø17.86x2.62 Ø15	3
25	99378950	Bolt M10x85 Zinc	8
26	94749000	Spring, Ø19x17, Ø15	3
27	81211256	Spring Ring, Ø15	3
28	81211451	Scraper Ring, KC, Ø15	3
29	90351800	O-ring, Ø20x1.5 Ø15	3
30	90552500	Sealing Ring, KC, Ø15x21x9	3
31	90360400	O-ring Ø25.12x1.78 Ø15	6
32	90516900	Anti-extrusion Ring Ø26x29x1 Ø15	3
33	90508930	Anti-extrusion Ring Ø15x21x1.5	3
34	81211070	Intermediate Ring, KC, Ø15	3
35	90260800	Sealing Ring, LP, Ø15x22x5	3

No.	Part No.	Description	Qty.
36	81210670	Bottom Ring, Ø15	3
37	96738000	Washer Ø17.5x23x1.5	1
38	98210050	Plug, G3/8"x13	1
39	96751400	Washer, Ø21.5x27x1.5	1
40	98218700	Plug, G1/2"x10	2
41	99366800	Bolt M10x25	2
42	96698000	Washer, Ø7.5x18x0.5	3
43	82210782	Gasket Ø3x99	1
44	81010022	Crankcase	1
45	58210451	Drip Cover	1
46	90156550	Seal Ø15x24x5.0/7.0	3
47	81050066	Plunger Guide	3
48	97734000	Pin Ø10x29.5	3
49	44030022	Plunger Rod	3
50	99183700	Bolt M6x14	8
51	90385900	O-ring, Ø25.07x2.62	1
52	53210851	Oil Sight Glass	1
	44022065	Crank Shaft (ME11585G8)	1
53	44020965	Crank Shaft (ME11595G8)	1
	44021265	Crank Shaft (ME11511G8)	1
54	90067100	Stop Ring	1
55	90063500	Stop Ring	1
56	53150100	Side Cover	1
57	90389800	O-ring, Ø56.82x2.62	1
58	91833100	Bearing	2
59	90169000	Oil Seal	1
60	10051822	Flange, Gas Engine	1
61	99191200	Bolt, M06x30	4
62	99275500	Bolt, 5/16"-24x1	4
63	96710400	Washer, Ø10.5x16x1	4
64	91856800	Needle Bearing	1
65	90409700	O-ring, Ø55.56x3.53	1
66	98210500	Dipstick	1
67	90392600	O-ring, Ø120.32x2.62	1
68	81160022	Rear Cover	1
69	98204250	Plug, G1/4"x9	1
70	90358500	O-ring, Ø10.82x1.78	1
71	99179000	Bolt, M6x06	1

REPAIR KITS

TORQUE SPECS*

Kit No	269	271	292	358	359
ITEM NO's INCLUDED IN KIT	2,3,4,5,6,13,14,15,16,(7),(18)	46	8,9,19,20	22,24,28,29,30,31,32,33,35	22,23,24,26,27,28,32,33,34,35
NUMBER OF CYLINDERS KIT WILL SERVICE	3	3	3	3	1

Position	Ft. Lbs.
9	95.88
10	4.43
19	44.25
25	18.44
38	29.5
40	29.5
41	33.19
50	14.75
61	7.38
69	14.75

* Decrease torque by 20% if threads are lubricated

