

Owner's Manual

- *Installation*
- *Use*
- *Maintenance*

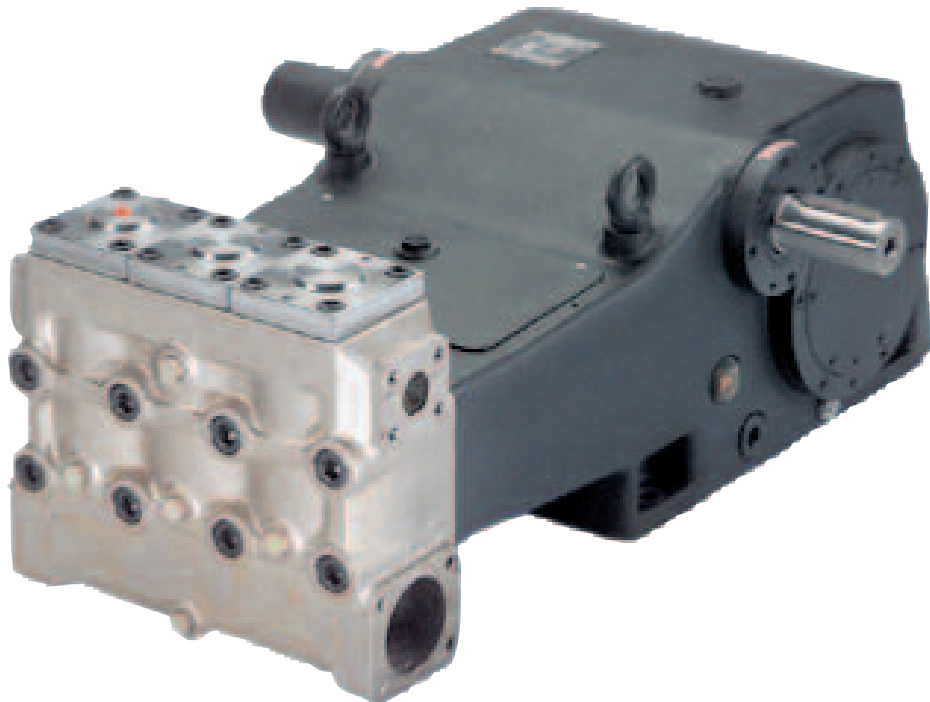

INDEX

1.	INTRODUCTION	Page 3
2.	SYMBOL DESCRIPTIONS	Page 3
3.	SAFETY	Page 3
	3.1 General warnings for safe operation	Page 3
	3.2 High pressure unit safety requirements	Page 3
	3.3 Safety of operation	Page 4
	3.4 General procedures for high pressure lance/gun operation	Page 4
	3.5 Safety of maintenance	Page 4
4.	PUMP IDENTIFICATION	Page 5
5.	TECHNICAL FEATURES	Page 5
6.	DIMENSIONS AND WEIGHT	Page 5
7.	GENERAL INFORMATION ABOUT SPECIFIC PUMP USE	Page 6
	7.1 Water temperature	Page 6
	7.2 Maximum flow and pressure ratings	Page 6
	7.3 Lowest operating RPM	Page 6
8.	CONNECTION AND PLUGS	Page 6
9.	PUMP INSTALLATION	Page 7
	9.1 Positioning	Page 7
	9.2 Direction of rotation	Page 7
	9.3 Water connections	Page 7
	9.4 Suction line	Page 7
	9.5 Filtration	Page 8
	9.6 Delivery time	Page 8
10.	START UP AND RUNNING PROCEDURES	Page 9
	10.1 Before start up	Page 9
	10.2 Starting up	Page 9
	10.3 Water leakage	Page 9
11.	MAINTENANCE INSTRUCTIONS	Page 10
	11.1 Crank mechanism maintenance	Page 10
	11.2 Fluid end maintenance	Page 10
	11.3 Pumping unit maintenance	Page 12
12.	SCREW CALIBRATION	Page 15
13.	MAINTENANCE TOOLS	Page 15
14.	PUMP STOPPED FOR LONG TIME	Page 15
15.	PRECAUTIONS AGAINST FREEZING	Page 15
16.	EXPLODED VIEWS AND PARTS	Page 16
17.	TROUBLE SHOOTING	Page 20

1. INTRODUCTION

LH high pressure water plunger pumps have been designed for long life industrial duties and provided they are correctly installed and maintained will give long trouble-free operation. Read and understand this manual before using your pump; it contains the necessary information for the correct installation, use and maintenance as well as some practical suggestion for trouble shooting.

Upon receipt of your pump, inspect for overall good condition and that no items are missing. Any missing item or damage should be reported before installing and starting the pump.

2. SYMBOL DESCRIPTIONS

**Warning**

Potential Danger

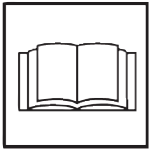

Read carefully and understand the manual before operating the pump

**Danger**

High Voltage

**Danger**

Wear protective mask

**Danger**

Wear goggles

**Danger**

Wear protective gloves

**Danger**

Wear protective boots

3. SAFETY

3.1 General warnings for safe operation

The misuse of a high pressure water unit and the non-observance of the pump installation and maintenance instructions may cause serious damages and/or injuries to people or properties or both.

Any Manufacturer/Operator requested to assemble/use a high pressure water unit should be competent to do so, should have the necessary knowledge on every high pressure component installed in the unit and on the precautions to be taken in order to guarantee the largest safety margins during operation. No precaution, so far as is reasonably practical, should be left out in the interest of safety, both from the Manufacturer and the Operator.

3.2 High pressure unit safety requirements

1. A safety valve should be installed in any delivery line and should be sized to discharge or by-pass the entire pump flow rate
2. High pressure unit components, with particular regard for those units working outside, should be adequately protected against rain, frost and heat.
3. Electric components and wiring should be provided with an adequate degree of protection, able to protect them against spray coming from any direction. They should also be suitable for working in a wet environment.
4. High pressure hoses and any other accessory under pressure should be sized in accordance with the maximum unit working pressure and must always work within the safety margins indicated by the nose/ accessory Manufacturer.
5. High pressure hose ends should be fastened to a steady object in order to prevent them from dangerous sweeping around, should they burst or come off their end fittings.
6. Proper safety guards should be provided to adequately cover transmission joints, pulleys, belts or auxiliary drives.



3.3 Safety of operation

The access into the area when a high pressure unit is working should be strictly prohibited to unauthorized personnel. The area should be suitably enclosed and its perimeter, so far as is reasonably practical, cordoned off and proper warning notices displayed in prominent positions.

Personnel authorized to enter that area should have been previously trained to do so and informed of the risks arising from failures, misuse and any foreseeable circumstance which may occur during operation. Before starting the pump unit and bringing it up to pressure the Operator is requested to carry out the following checks:

1. Make sure that a correct water supply to the pump is provided.
2. Make sure that water inlet filters are properly clean.
3. Electrical components and wiring, with special emphasis on connections, junction boxes, switches and supply cables should be free from external damage (i.e. exposed and broken wires) and adequately protected against water.
4. High pressure hose should not show apparent external wear and the fittings at both ends should be free from signs of erosion or corrosion.
5. Make sure that all fluids (lubricating oil for pump and engine, cooling water, hydraulic fluids) are at proper levels and in good condition.
6. Make sure the safety guards are in good condition.

The work should stop immediately and the pressure must be released in the event that leakage becomes apparent or if any person becomes aware of a change in condition or any hazard existing or being introduced. Any failure must be promptly reported and then checked personnel.



3.4 General procedures for high pressure gun/lance operation

1. The Operator should take reasonable care for the safety of himself and of other persons who may be affected by his acts or omission at work. His actions should always be governed by his good sense and responsibility.
2. The Operator should wear suitable waterproof protective clothing, having regard to the type of work being undertaken. The clothing set should include adequate hand protection, suitable boots able to ensure proper grip on wet floors, helmet provided with full face shield, waterproof garment providing full cover to the Operator, including his arms.
As most water jets produce noise levels in excess of

90 dB(A) suitable ear protection is advised.

NOTE: *it must be emphasized that whereas protective clothing provides adequate protection against spray and flying particles, it does not constitute complete protection against the direct impact of the water jet. Additional protections in the form of suitable metal shields or barriers may be necessary for certain jetting operation.*

3. In most jetting operations it is an accepted practice to employ a team of Operators consisting of two members at least, in order to provide mutual assistance in case of need and to rotate their duties in case of long and heavy work. While the first Operator holds the gun, the second Operator attends the pump unit, keeping close watch on the first Operator for signs of difficulty or fatigue, and watching the surrounding area for intrusion by other persons or unsafe situations. If required, he will shut off the pressure unit until it is safe to continue.
4. The area in which the work is to proceed should be clear of loose items and debris to prevent tripping and slipping hazards.
5. The water jet should be directed only and always against the workpiece even during preliminary operating tests prior to starting work.
6. Where applicable, proper side shields should be suitable placed to safeguard personnel and equipment against contact with grit or particles removed by the water jet.
7. On no account must the Operator be distracted during operation until the jet has been stopped. Personnel having reason to enter the water jetting area should wait until the jet is stopped and his presence known.
8. Each team member must always be aware of the actions and intentions of other team members in order to prevent any dangerous misunderstanding occurring during jetting operation.
9. The pump unit should not be started and brought up to pressure unless each team member is in his designated position, the nozzle directed to the workpiece and the lance or gun securely held.

3.5 Safety of maintenance

Apart from the working pressure regulation no attempt should be made to adjust any nut, hose, fitting, etc., while that part of the system is under pressure. The pump should be stopped and any pressure in the line released prior to making any adjustments.

1. The high pressure water unit should be maintained in accordance with the Manufacturer's instructions.
2. The unit should be maintained only by competent personnel
3. Service and maintenance should be carried out with proper tools in order to prevent any damage on high pressure connections and fittings.
4. Use of other than original spare parts is strictly forbidden.

4. PUMP IDENTIFICATION

Each pump is fitted with a rating plate (see Fig. 1) containing the following information:

2. pump model and version
3. serial number
4. max RPM
5. max operating pressure (bar)
6. oil capacity (ltr) and oil specification
7. gear box ratio
8. max flow rate (l/min)

Pump model, pump version and serial number should be specified when ordering spare parts. Should the pump be modified (i.e by changing the original version) than any change should be mentioned on the rating plate for future reference.

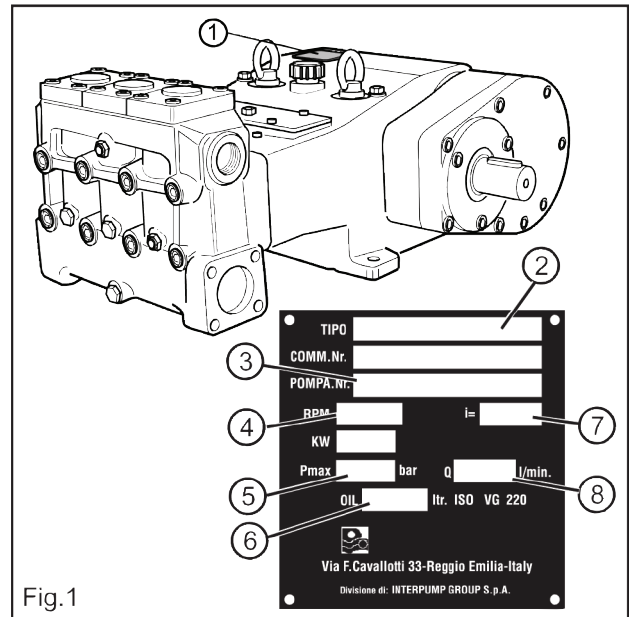

Fig.1

5. TECHNICAL FEATURES

Model	Flow Rate	Gear Box			Pressure		Power			
		A 1900 RPM R=1:3.389	B 1750 RPM R=1:3.158	C 1500 RPM R=1:2.95			A 1900 RPM	B 1750 RPM	C 1500 RPM	
LH40	GPM	50	49.7	45.4	PSI	4350	HP	148	147	135
	l/m	190	188	172	Bar	300	kW	109	108	95
LH45	GPM	63	62.9	57.6	PSI	3500	HP	150	149	137
	l/m	240	238	218	Bar	240	kW	110	109	101
LH50	GPM	78	77.4	71.1	PSI	2900	HP	154	153	141
	l/m	296	293	269	Bar	200	kW	113	112	104
LH55	GPM	94	93.8	86.1	PSI	2300	HP	148	148	136
	l/m	358	355	326	Bar	160	kW	109	109	100
LH60	GPM	113	112	102	PSI	2050	HP	155	154	142
	l/m	428	423	388	Bar	140	kW	114	113	105

6. DIMENSIONS AND WEIGHT

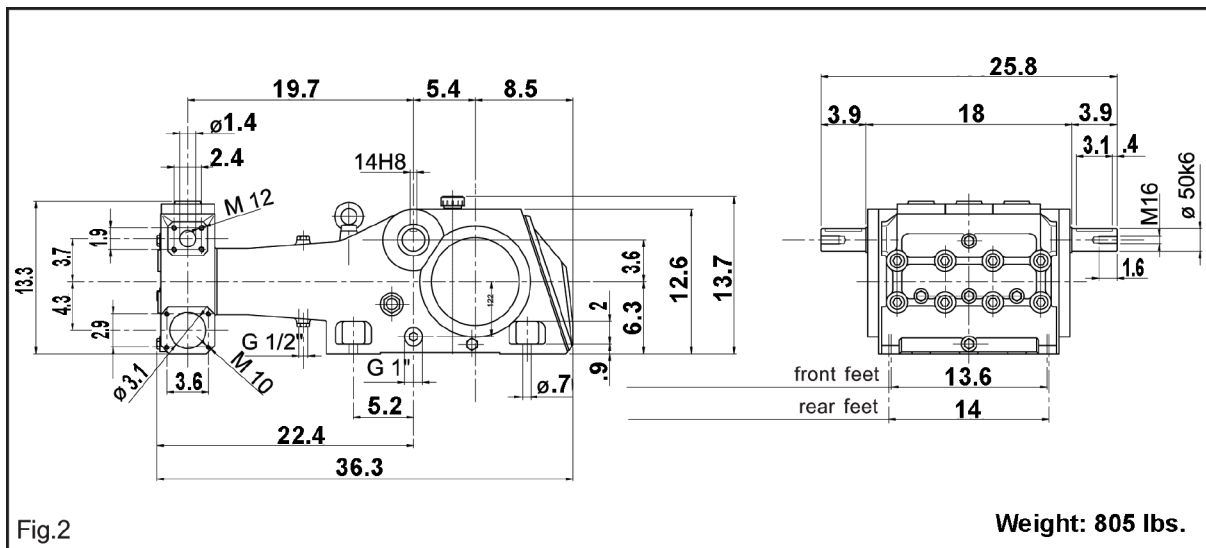

Fig.2

Weight: 805 lbs.

7. GENERAL INFORMATION ABOUT PUMP USE



The LH pump has been designed to pump fresh filtered water at room temperature. LHZ and LHN special stainless steel versions are also available for critical fluids.

7.1 Water temperature

Water temperature is critical for the pump life, the higher it is, the more likely it is to create cavitation, resulting in premature seal and valve failures.

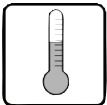

Below is the temperature chart and relevant limitations:

<104°F	Water is considered to be at room temperature.
from 104°F to 140°F	<p>feed the plunger pump with a centrifugal pump supplying at least twice the plunger pump volume at 30 to 45 PSI</p> <p>reduce pump rated RPM by 30% to 50%</p> <p>Make sure the crankshaft turns as indicated by the arrows located neat the drive shaft projection</p>
>140°F	standard pump not suitable, contact our Customer service Department

7.2 Max flow and pressure ratings

The performance data indicated in the catalog and on the rating plate refer to the maximum performance of the pump. The use of the pump below the rated performances does not allow the drop in power absorbed to be balanced by altering the pressure or volume of the pump above its maximum value.

7.3 Lowest operating RPM

The lowest operating speed of the crankshaft for all LH's (all versions) is 350 RPM

8. CONNECTIONS AND PLUGS

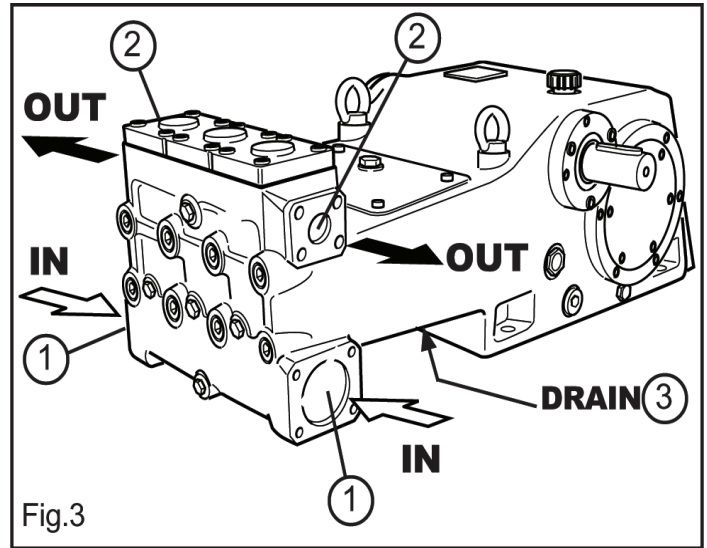

LH pumps are provided with (Fig. 3):

- 1 - 2 inlet ports IN Ø 3".
Suction line connection to any of the two inlet ports is acceptable, the port not being used should be sealed with the correct plug.
- 2 - 2 outlet ports OUT Ø 1.4".
- 3 - 1 hole DRAIN provided underneath the crankcase and designed to drain out the water leakage of the pressure packings. **This hole must always be left open (see paragraph 10.3, Fig 7, page 9).**

9. PUMP INSTALLATION

9.1 Positioning

The pump should be installed flat on a rigid base by means of the four 3/4" feet. The base should be rigid enough to avoid any misalignment or flexing of the pump/transmission coupling axis due to the torque involved during operation.

On no account should the pump be installed in such a way its fluid end rests on the base where the pump is mounted. The fluid end should be left free and not subjected to any force. (Fig 4).

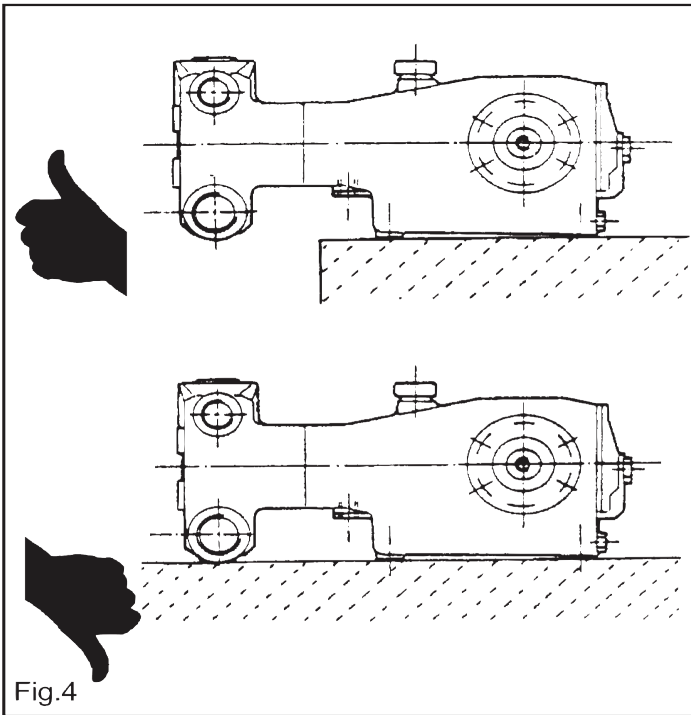

9.2 Direction of rotation

Fig. 5 shows the correct direction of rotation looking at the pump from the fluid end side. Two arrows stamped on the crankcase nearby the crankshaft provide the information as well.

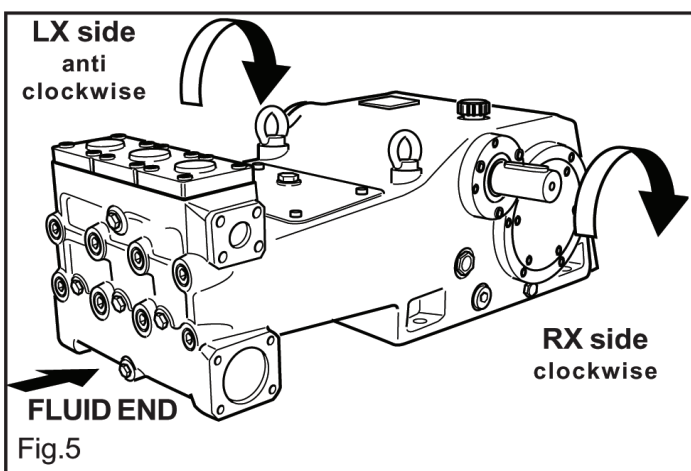

9.3 Water connections

In order to isolate the high pressure equipment from the pump vibrations it is suggested, where applicable, to use flexible hoses for both suction and delivery lines at least for the first length. The flexible suction hose must be rigid enough to prevent it from collapsing during the suction stroke, when a partial vacuum may occur.

9.4 Suction line

Plunger pumps are not self priming therefore a positive suction head should always be provided. Information for the correct suction line:

1. Internal diameter should be at least 3", in any point, possibly larger depending on the drop in pressure due to the length and shape of the line.
2. Should be as straight as possible minimizing changes in size and direction and positioned in such a way to allow air pockets and bubbles to escape.
3. Should be perfectly airtight.
4. Should be completely free from 90° elbows, diameter reductions, counter slopes, "T" connections and should not be connected to other pipelines.
5. Should be positioned in such a way to prevent the pipe emptying after the pump stops.
6. Do not use high pressure flexible hoses for the suction line.
7. Do not use high pressure hydraulic fittings like 90° elbows, high pressure adapters, high pressure 3 or 4 way nipples and so on.
8. Do not install any kind of detergent injector along the suction line.
9. Do not install standing valves, check valves or other kind of one-way valves.
10. Make sure that the feed tank capacity and the water minimum level do not give rise to turbulence at the tank outlet port, which, in turn, might create cavitation at the pump.
11. Do not connect the by-pass line from the valve directly to the pump suction line.
12. The water flow from the valve should be directed back in the tank. Make sure that the by-pass and tank feeding flows to not give rise to turbulence at the tank outlet port, which, in turn, might create cavitation at the pump. Proper baffle plates should be provided inside the tank.
13. Before connecting the suction line to the pump inlet port make sure the pipe is perfectly clean inside.

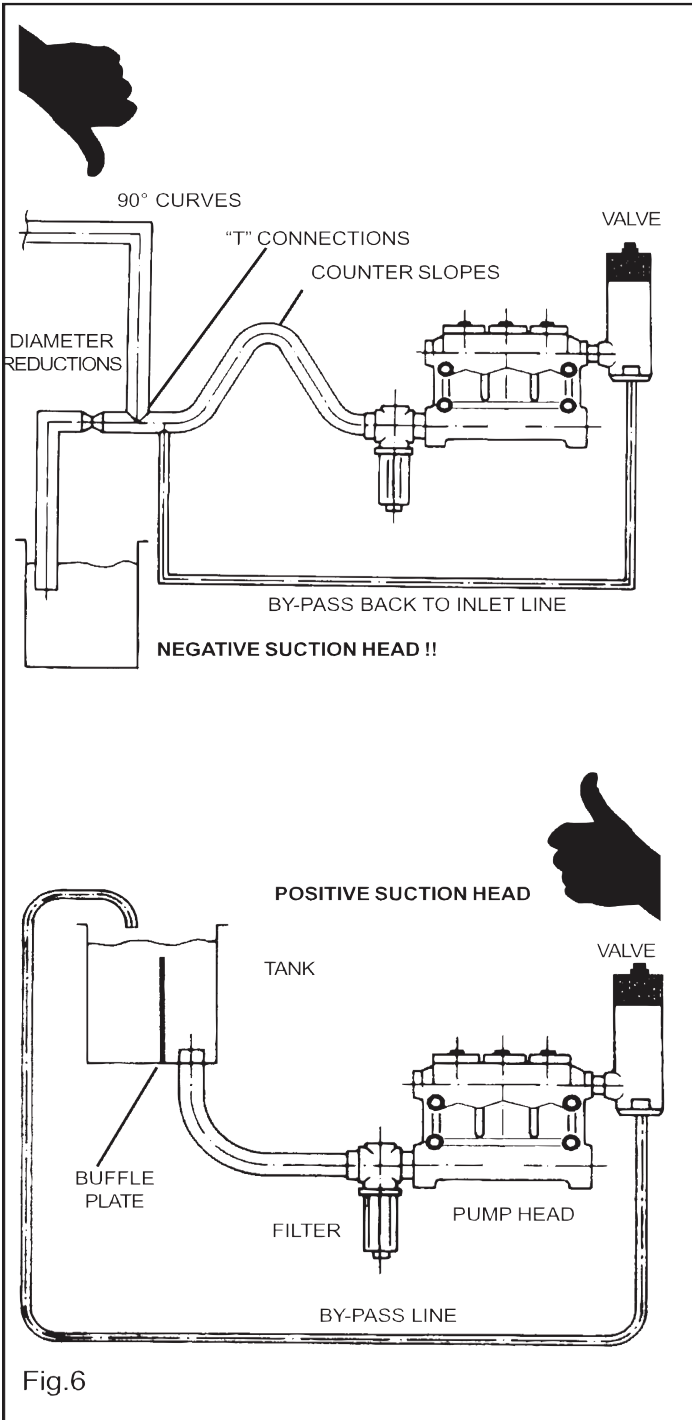

Fig.6

9.5 Filtration

All pumps require a suitable filter. The filter should be installed as close as possible to the pump, should allow easy inspection and have the following characteristics:

1. The filter capacity should be at least three times the rated pump volume.
2. Filter port diameters should not be smaller than the pump inlet ports.
3. Filtration degree in between 50 and 80 mesh (360 to 200 microns).

IMPORTANT NOTE: In order to properly safeguard the pump it is very important to plan cleaning of the filter with a frequency depending on the water quality, filtration degree and number of hours of each application.

9.6 Delivery line

For a correct delivery line comply with the following instructions:

1. The first length of delivery hose should be flexible in order to isolate the pump vibrations from the rest of the system.
2. Use only high pressure hoses and fittings able to guarantee the largest possible safety margins in any working conditions.
3. A suitable relief valve should be installed in the delivery line.
4. Use glycerine filled pressure gauges, as the most suitable for pulsating loads.
5. When designing the delivery line, take into proper account the unavoidable drop in pressure, due to its length and size.
6. If necessary, the effects of the pump pulsations can be reduced by installing a proper pulsation dampener in the pressure line.

10. START UP AND RUNNING PROCEDURES

10.1 Before start up

Before start up make sure that the following conditions have been complied with:

1. Suction line should be connected: **the pump must never run dry.**
2. Suction line must be perfectly air-tight.
3. Any ON-OFF valve in between the pump and water source should be open and make sure the water gets into the pump freely.
4. Set the pressure line in dump mode in order to let the air in the pump get out easily thus facilitating the pump priming.
5. Make sure all suction/delivery line connections are fully tightened.
6. Joint alignment, belt tightening and PTO shaft inclination tolerances should remain within the values indicated by the transmission Manufacturer.
7. Make sure the oil level is correct.

Note: in case the pump has not run for a long period of time check the suction and delivery valves for scaling (see paragraph 11.2).

10.2 Starting up

1. Pump and motor/engine should start offload, set the regulating valve to zero or set the pressure line in dump mode by means of proper dumping devices.
2. When starting the pump up for the first time or after every wiring re-connection check for the proper direction of rotation.
3. Check that the rotating speed does not exceed the rated value.
4. Before putting the pump under pressure let it run for some time until the oil flows freely.
5. Before stopping the pump release the pressure from the system by operating the dump device or by releasing the regulating valve and reduce RPM to a minimum (diesel applications).

Note: in case of feeding by a centrifugal pump, make sure that the plunger pump start only when the correct inlet pressure is provided.

10.3 Water leakage

During operation a small amount of water (a few drops a minute) is released from the pump fluid end; this leakage is designed to provide lubrication for the pressure packings. The leakage is drained out of the pump through a hole in the lower cover (Fig. 6). **This hole must always be kept open.**

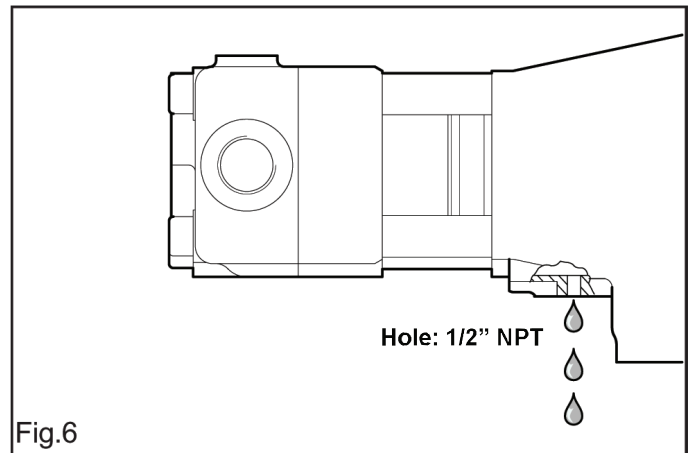

11. MAINTENANCE INSTRUCTIONS

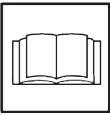

11.1 Crank mechanism maintenance.

Check oil level through the oil level indicator 1, Fig 8 at least on a weekly basis.

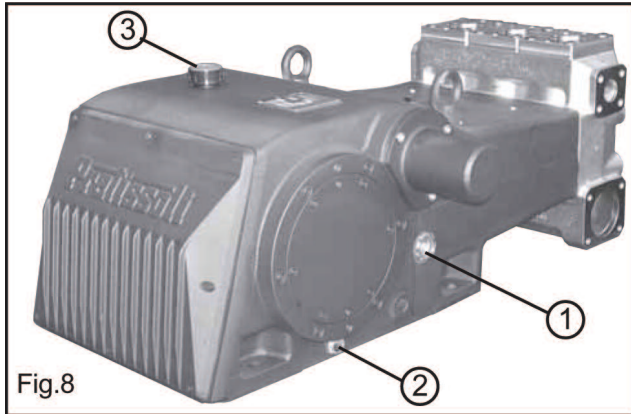

Fig.8

If necessary, top up from the oil plug 3, Fig. 8. Check the oil when cold and change the oil when still hot (pump still at working temperature.). In order to drain the oil from the pump remove the magnetic plug 2, Fig. 8. At every oil change clean the magnetic plug 2, Fig. 8 and check the lower cover of Fig. 7 for grease sediments or deposits.

OIL CHANGES	Hours	Qty.	Oil Type
First Change	50	3.1 quarts	ISO 220
Subsequent Changes	500		

Oil should be changed at least once a year.

Recommended oils:

BRAND	TYPE
AGIP	ACER 220
ARAL	MOTANOL HP 220
AVIA	AVILUB RSL 220
BP	ENERGOL HL 220
CASTROL	ALPHA ZN 220
ESSO	NUTO 220
FINA	SOLNA 220
IP	HYDRUS 220
MOBIL	DTE OIL BB
SHELL	TELLUS C 220
TEXACO	REGOL OIL 220
TOTAL	CORTIS 220

11.2 Fluid end maintenance

The fluid end does not require periodical maintenance. Service operations are limited to valve inspection and/or replacement, when necessary. In order to remove the valves:

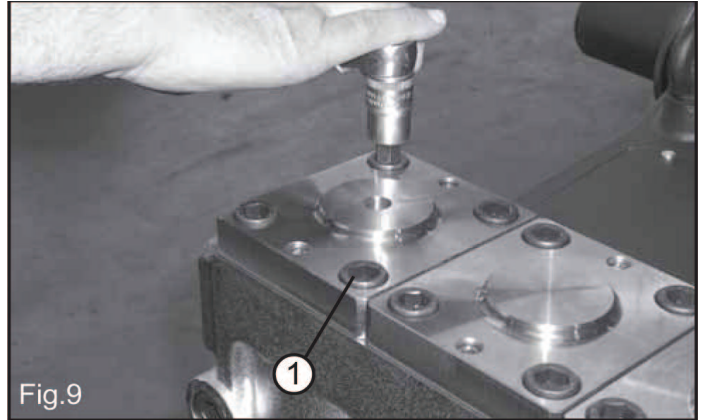

Fig.9

Loosen and remove the valve cover screws (1, Fig. 9).

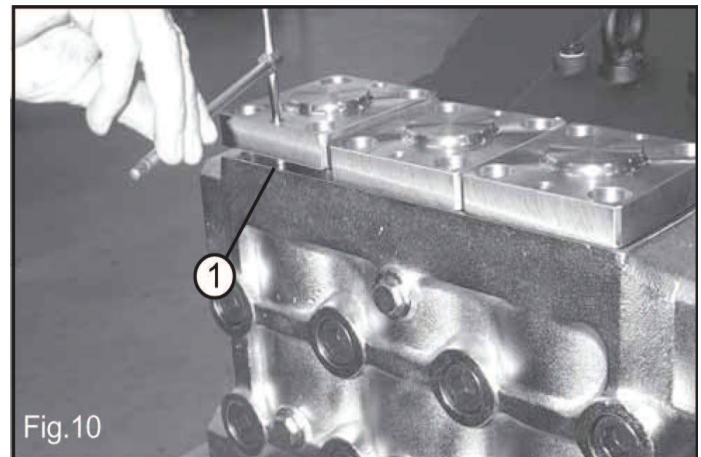
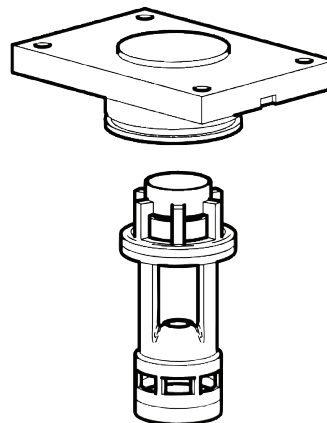

Fig.10

Tighten the two grub screws (1, Fig. 10) of each valve cover until the complete valve unit moves upward enough to allow easy extraction.



Valve components of each valve unit are pressed together in one single block and therefore they can be easily replaced and installed back in place. Separating the various components of the valve unit is carried out by means of simple tools as shown in Fig. 11, 12, 13 on page 11).

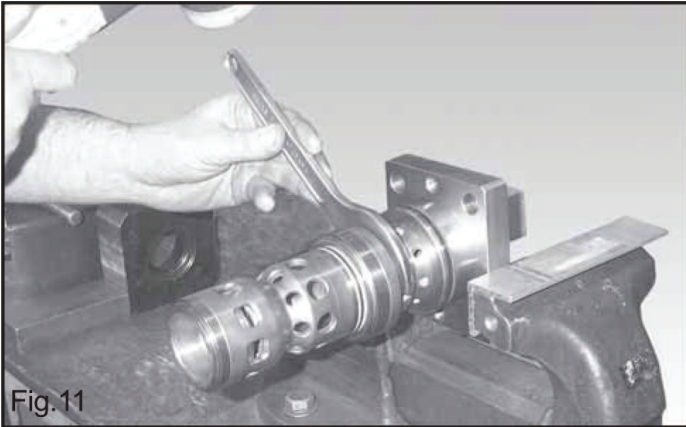

Fig.11

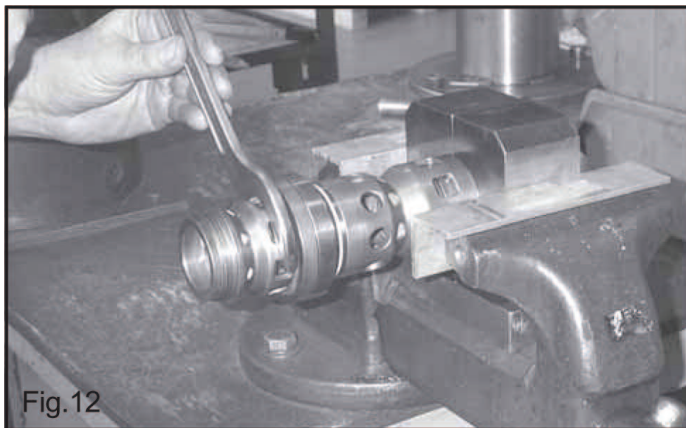

Fig.12

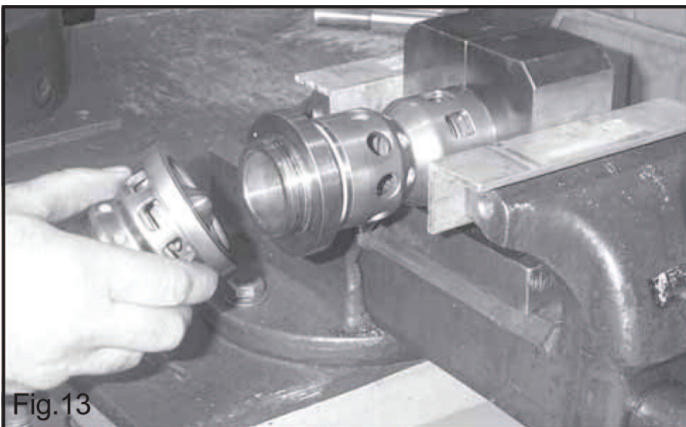

Fig.13

Check the valve components for wear and replace where necessary. **Every time valves are inspected, all o-rings and valve covers should be replaced.**



Reassemble the valve units and fit them back in the fluid end. Valve cover screws should be tightened with a torque wrench set for 86.7 ft. lbs.



IMPORTANT:
BEFORE REPOSITIONING THE VALVE UNITS CLEAN AND PERFECTLY DRY ALL VALVE HOUSINGS INSIDE THE FLUID END (SEE ARROWS).

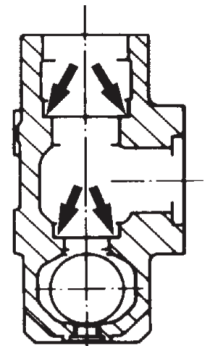

Fig.14

Should excessive scaling inside the fluid end hinder the valve extraction open one of the two lateral inlet ports, remove the three plugs, Fig. 15, insert our special tool p/n F200030090 (or a corresponding one) and push the valve unit out as shown in Fig. 15.

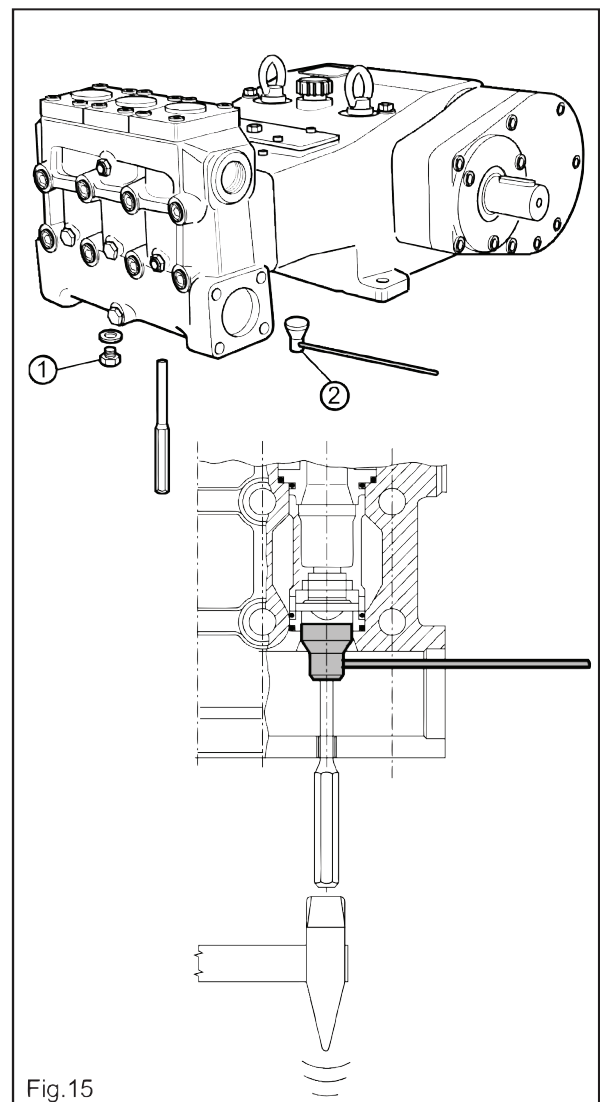

Fig.15

11.3 Pumping unit maintenance

The only maintenance operation required for the pumping unit is to periodically check the amount of water drained out by the pump through the hole provided in the lower cover (Fig 6, page 9). It clearly shows the pressure packing state of wear; replace them if water dripping becomes continuous and not intermittent.

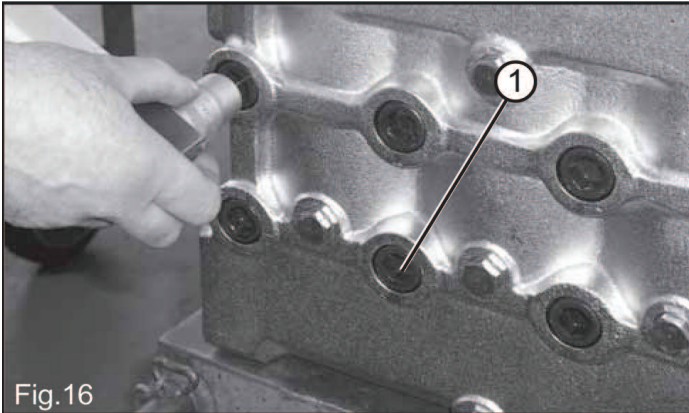

Fig.16

For inspecting the pumping unit, remove the head by loosening the eight head screws (1, Fig. 16).

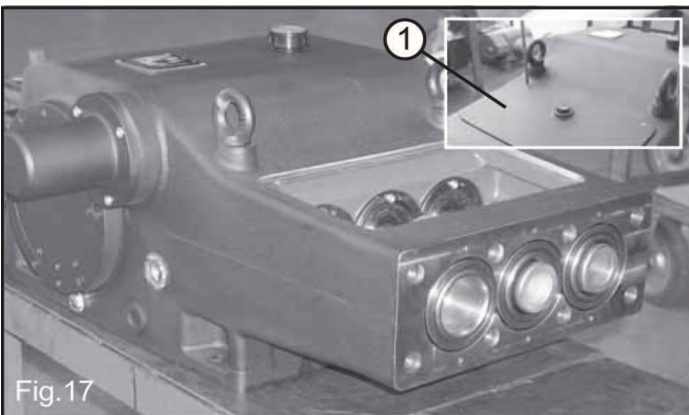

Fig.17

Remove the upper cover by loosening the four screws (1, Fig. 17).

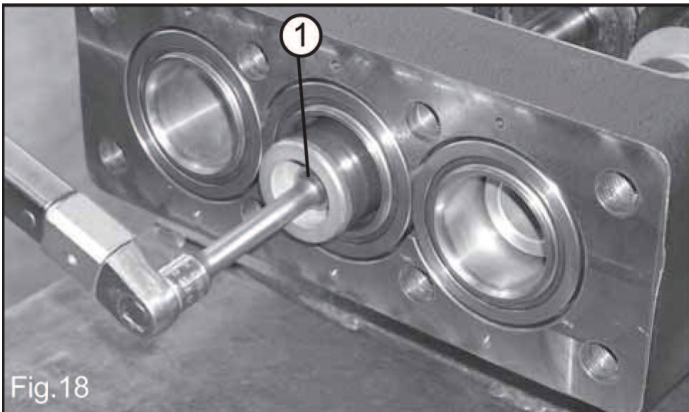

Fig.18

Loosen and remove the plunger screws (1, Fig. 18).

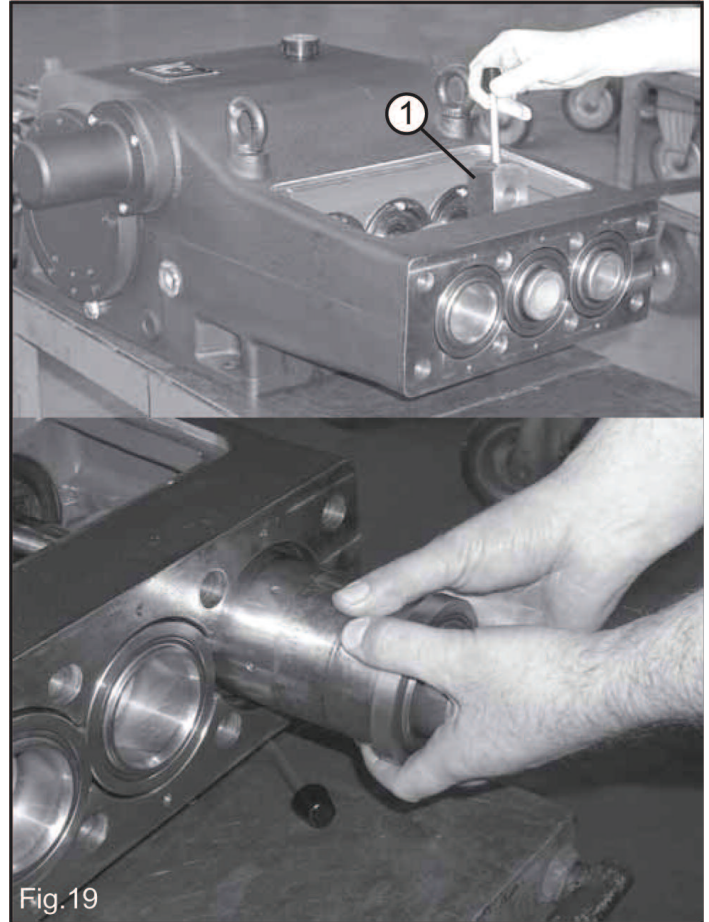

Fig.19

Push the plungers forward by rotating the crankshaft, then introduce our tool p/n F200030060 (or equivalent) (1, Fig. 19) in between the piston guide and the cylinder. With the tool in place, rotate the crankshaft until the cylinder is pushed out together with the plungers (Fig. 23). Repeat the operation for each pumping unit.

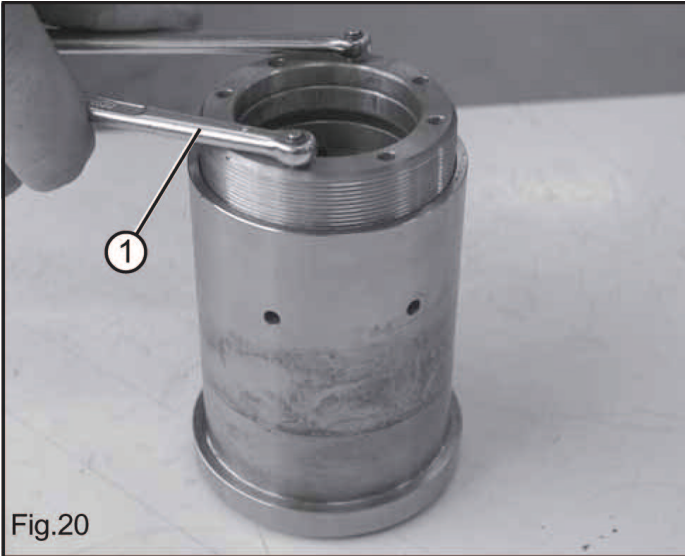

Fig.20

Disassemble the packing support from the cylinder by means of a pin key (1, Fig. 20).

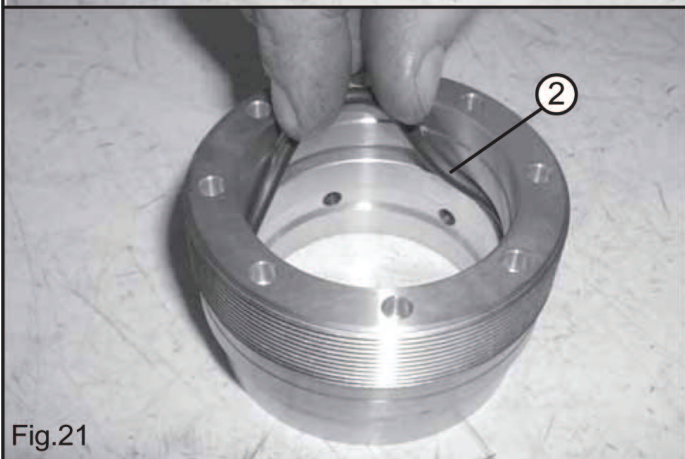
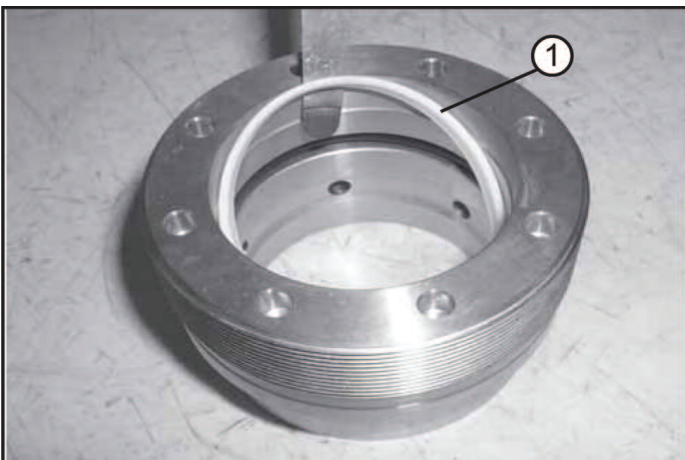

Fig.21

Remove the scraper (1, Fig. 21) and o-ring (2, Fig 22) from the packing support.

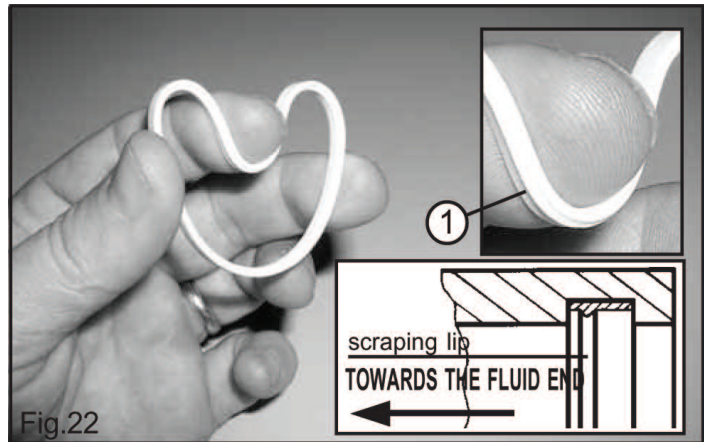

Fig.22

In order to fit the new scraper in place, shape it manually as shown in Fig. 22. **VERY IMPORTANT!** The scraper is provided with an internal lip which performs the correct scraping effect only if oriented toward the fluid end. See window inside Fig. 22.

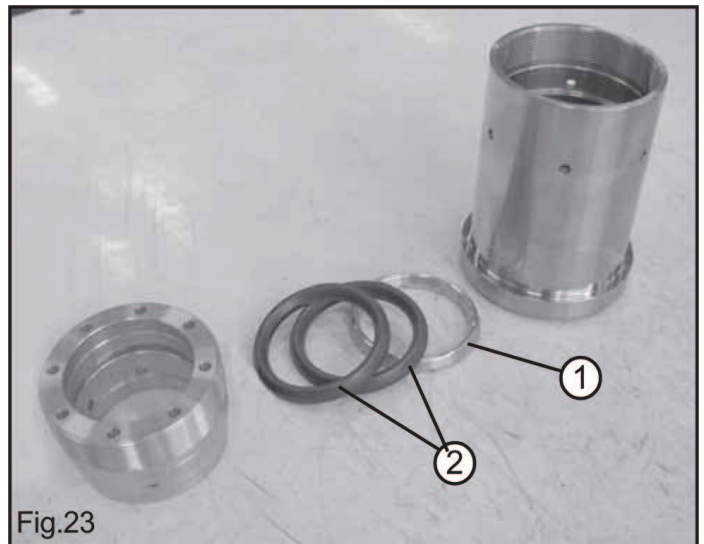

Fig.23

Before reassembling the pumping unit carefully clean the pressure packing seat in the cylinders, fit in place the packing ring (1, Fig. 23) and then the pressure packings (2, Fig. 19). A little bit of grease helps sliding the packings into the packing support. **Pressure packings and o-rings should always be replaced at every disassembling of the pumping unit.**

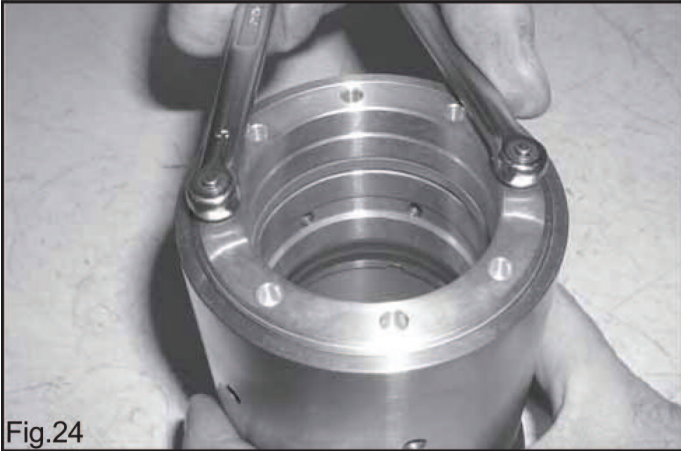

Fig.24

Set up the complete package without tightening the packing support (1, Fig. 24) but making sure that the pressure packings snap in place.

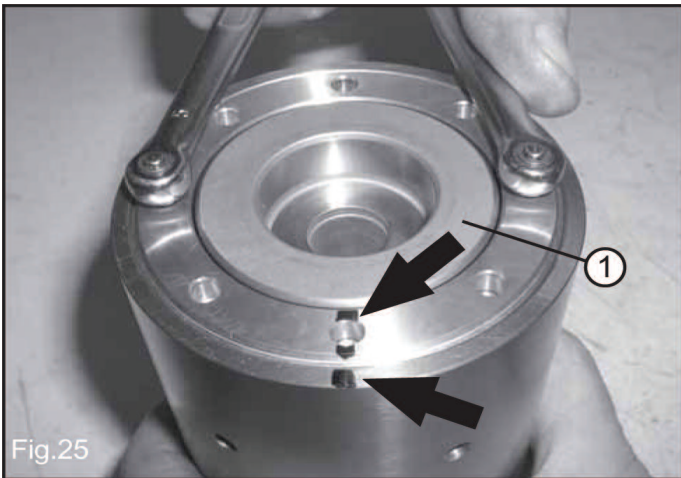

Fig.25



Fig.26

For the correct load of the pressure packings proceed as follows:

- Fit the plunger in the pumping unit (1, Fig. 25)
- Mark the position of any one of the 8 holes of the packing support referring at the cylinder (see arrows (Fig. 25).
- Tighten the packing support 1/8 of a complete turn (45 degrees) or of the distance of one hole (see arrows Fig. 26).

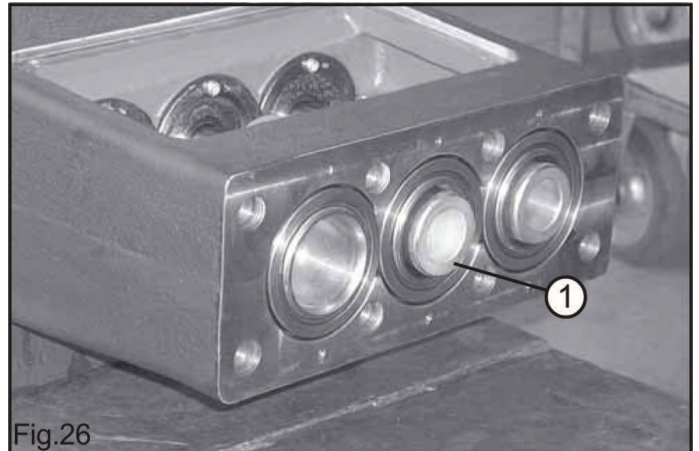

Fig.26

Fit the pumping units back in the pump crankcase (1, Fig. 26).



Tighten the plunger screws with a torque wrench set for 72 ft. lbs. Mount the head back in place and tighten the eight head screws with a torque wrench set for 260 ft. lbs.

12. SCREW CALIBRATION



Screw calibration is to be carried out by means of a torque wrench only:

DESCRIPTION	Ft. Lbs.	N-m	Kgm.
Valve cover screws	86.7	117.6	12
Head Bolts	260.3	353	36
Plunger bolts	72.3	98	10
Connecting Rod Screws	54.2	73.5	7.5

13. MAINTENANCE TOOLS



The following tools are designed to facilitate mounting and dismounting operations of some pump components:

- For disassembling:
- packing support extractor F200030060
 - valve extractor F200030090

14. PUMP STOPPED FOR LONG TIME



Before starting the pump for the very first time after a long period from the date of shipment check for the correct oil level, check the valves as indicated in chapter 11 and then comply with the starting procedures indicated in chapter 10. When a long inactivity is scheduled drain the entire suction and delivery line and then run the pump dry **only for a few seconds** in order to drain out the water collected inside the fluid end.

15. PRECAUTIONS AGAINST FREEZING



In the risk of freezing the following precautions should be taken:

- After use drain the entire suction and delivery lines (filter included) by means of discharging devices, provided and positioned specifically for this purpose along the lowest point of the lines.
 - Run the pump only for a few seconds in order to drain the water collected inside the fluid end.
- Or when applicable
- Add a recommended amount of anti-freeze into the water tank and run the pump until the anti-freeze works all through the system.



If a pump is frozen or appears frozen ON NO ACCOUNT SHOULD THE PUMP BE OPERATED until the entire system has been thawed out.

16. EXPLODED VIEW AND PARTS LIST

LH

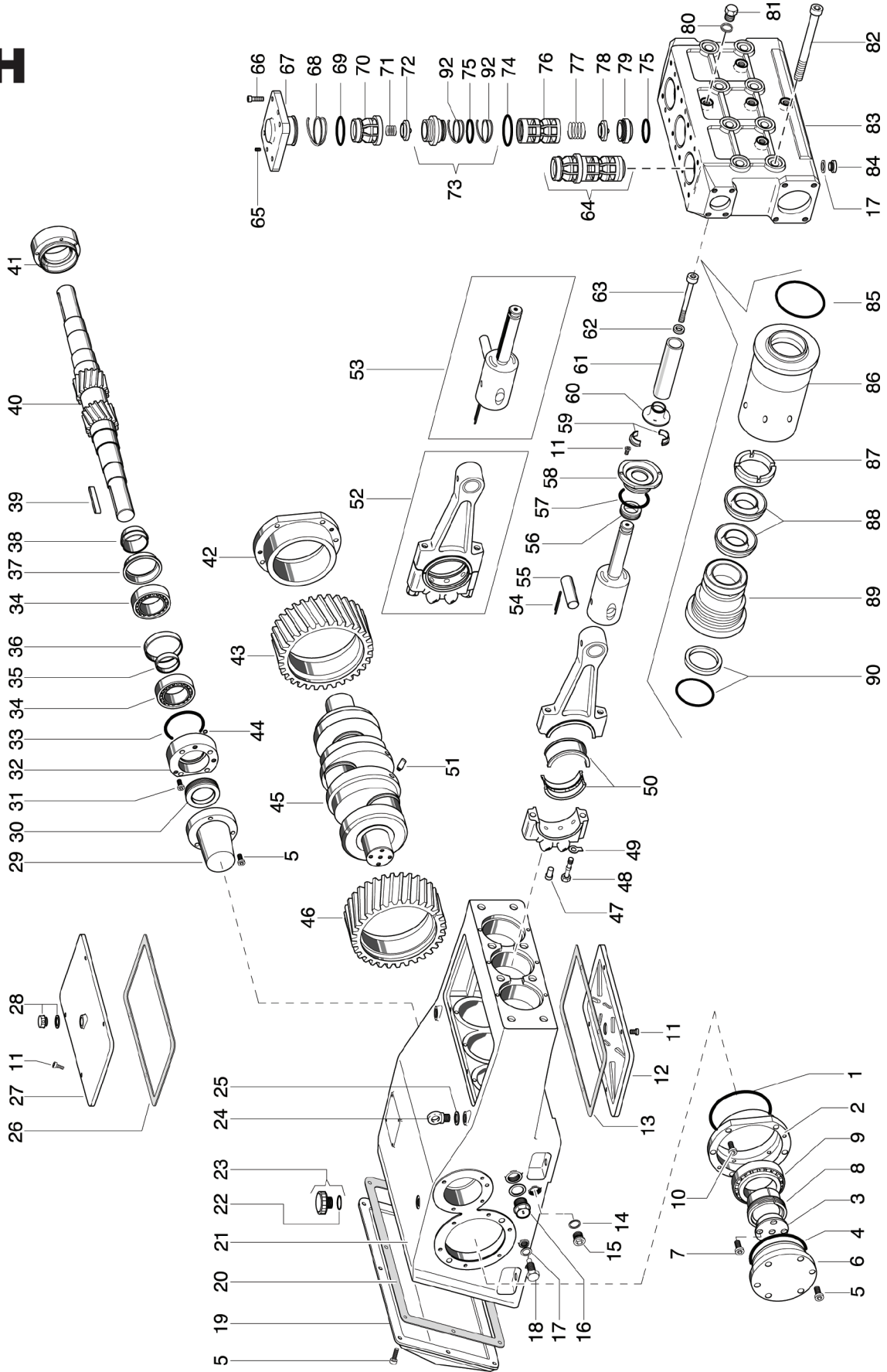

Item	Part #	Description	QTY.
1	F881010133	O-ring, Ø 183.82 x 2.62	2
2	F010100070	Left fearing support	1
3	F030000010	Bearing bushing retainer flange	2
4	F881010132	O-ring, Ø 152.07 x 2.62	2
5	F871121152	Screw, M8 x 20	23
6	F063400280	Bearing cover	2
7	F871131102	Screw, M12 x 25	8
8	F030000020	Bearing bushing	2
9	F811111017	Bearing	2
10	F871125154	Screw, M10 x 30	12
11	F871115152	Screw, M6 x 14	14
12	F040400050	Lower cover	1
13	F080600030	Lower cover gasket	1
14	F872043008	Aluminum washer Ø 1"	2
15	F821203006	Plug G1"	2
16	F801053012	Oil level indicator G 1"	2
17	F872043002	Aluminum washer, Ø 1/2"	5
18	F801057002	Magnetic plug, G 1/2"	2
19	F063400240	Back cover	1
20	F080600010	Back cover gasket	1
21	F060100160	Crankcase	1
22	F881010116	O-ring, Ø 29.82 x 2.62	1
23	F801054027	Oil filling plug G1"	1
24	F872026003	Eye bolt, M16	2
25	F030000030	Eye bolt spacer	2-4
26	F080600020	Upper cover gasket	1
27	F040400030	Upper cover	1
28	F801056002	Venting plug G 1/2"	1
29	F040400070	Crankshaft end cap	1
30	F881080026	Oil seal, Ø 55 x 75 x 10	2
31	F871121154	Screw, M8 x 30	8
32	F063400300	Left bearing cover	1
33	F881010130	O-ring, Ø 94.92 x 2.62	2
34	F811101019	Bearing	4
35	F031000020	Internal bearing spacer	2
36	F031000010	External bearing spacer	2
37	F061000000	Lubricating bushing	2
38	F031000000	Lubricating cone	2
39	F872097013	Pinion key	1
40	F052000020	Pinion, 1500 RPM (Z20)	1
	F052000050	Pinion, 1750 RPM (Z19)	1
	F052000160	Pinion, 1900 RPM (Z18)	1
41	F063400310	Right bearing cover	1
42	F010100080	Right bearing support	1
43	F052000000	Gear, 1500 RPM (Z59, left toothing)	1
	F052000030	Gear 1750 RPM (Z60, left toothing)	1
	F052000140	Gear, 1900 RPM (Z61, left toothing)	1
44	F881010003	O-ring, Ø 8.73 x 1.78	2
45	F050000060	Crankshaft	1
46	F052000010	Gear, 1500 RPM (Z59, right toothing)	1
	F052000040	Gear, 1750 RPM (Z60, right toothing)	1
	F052000150	Gear, 1900 RPM (Z61, right toothing)	1
47	F034000000	Connecting rod pin	3
48	F035000070	Connecting rod screw	6
49	F872067006	Lock washer, Ø 12	6
50	F023300000	Brass bearing	3
51	F002000000	Crankshaft pin	2
52	F250000030	Connecting rod assembly	3
53	F250001070	Piston assembly	3
54	F872142015	Retainer pin Ø 5 x 36	3
55	F071000050	Wrist pin Ø 35	3

Item	Part #	Description	QTY.
56	F881081001	Oil seal, Ø 35 x 47 x 8.5, Spec	3
57	F881010128	O-ring, Ø 72.69 x 2.62	3
58	F036400420	Piston oil seal cover	3
59	F030000070	Wiper bushing	3
60	F041200010	Wiper	3
61	F024200250	Plunger, LH40	3
	F024200260	Plunger, LH45	3
	F024200270	Plunger LH50	3
	F024200280	Plunger, LH55	3
	F024200290	Plunger, LH60	3
62	F872040004	Washer, Ø 14 Spec.	3
63	F871135520	Screw, M14 x 160, LH40-45	3
	F871135514	Screw, M14 x 100, LH50-55-60	3
64	F208005230	Valve assembly	3
65	F871245356	Screw, M10 x 20	6
66	F871135152	Screw, M14 x 40	12
67	F063200030	Valve cover	2
	F063200040	Valve cover, G 1/4"	1
68	F881112003	Antiextrusion ring	3
69	F881011252	O-ring, v 70 x 4 Spec.	3
70	F021200280	Delivery valve guide	3
71	F090200050	Delivery valve spring	3
72	F082200060	Delivery valve poppet	3
73	F205000110	Delivery valve seat	3
74	F881011168	O-ring, Ø 72 x 3 Spec.	3
75	F881011161	O-ring, Ø 56 x 3 Spec.	6
76	F021200260	Suction valve guide	3
77	F090200040	Suction valve spring	3
78	F082200050	Suction valve poppet	3
79	F081200060	Suction valve seat	3
80	F872041300	Copper washer, Ø 1/4"	5
81	680115	Plug, G 1/4"	5
82	F871151168	Screw, M20 x 160	8
83	F064100200	Manifold	1
84	F084000010	Plug, G 1/2", Nickel	3
85	F881011253	O-ring, Ø 72 x 4 Spec.	3
86	F062200090	Cylinder LH40	3
	F062200100	Cylinder, LH45	3
	F062200110	Cylinder, LH50	3
	F062200120	Cylinder, LH55	3
	F062200130	Cylinder, LH60	3
87	F031200100	Packing ring, LH40	3
	F031200110	Packing ring, LH45	3
	F031200210	Packing ring, LH50	3
	F031200220	Packing ring, LH55	3
	F031200230	Packing ring, LH60	3
88	F881020011	Pressure packing, LH40	6
	F881020012	Pressure packing, LH45	6
	F881020014	Pressure packing, LH50	6
	F881020015	Pressure packing, LH55	6
	F881020016	Pressure packing, LH60	6
89	F022300210	Packing support, LH40	3
	F022300220	Packing support, LH45	3
	F022300230	Packing support, LH50	3
	F022300240	Packing support, LH55	3
	F022300250	Packing support, LH60	3
90	F881061015	Scraper, LH40	3
	F881061017	Scraper LH45	3
	F881061018	Scraper, LH50	3
	F881061019	Scraper, LH55	3
	F881061021	Scraper, LH60	3
91	F881110127		3
92	F010500290	Antiextrusion ring	6

REPAIR KITS

Item	LH40	LH45	LH50	LH55	LH60
62-85-88-90	F1204	F1205	F1206	F1207	F1208
17-68-69-74-75-92	F1195				
1-4-13-17-20-22-26-30-33-44 49-54-56-57-62-68-69-74-75 80-85-88-90-92	F1209	F1210	F1211	F1212	F1213

LH

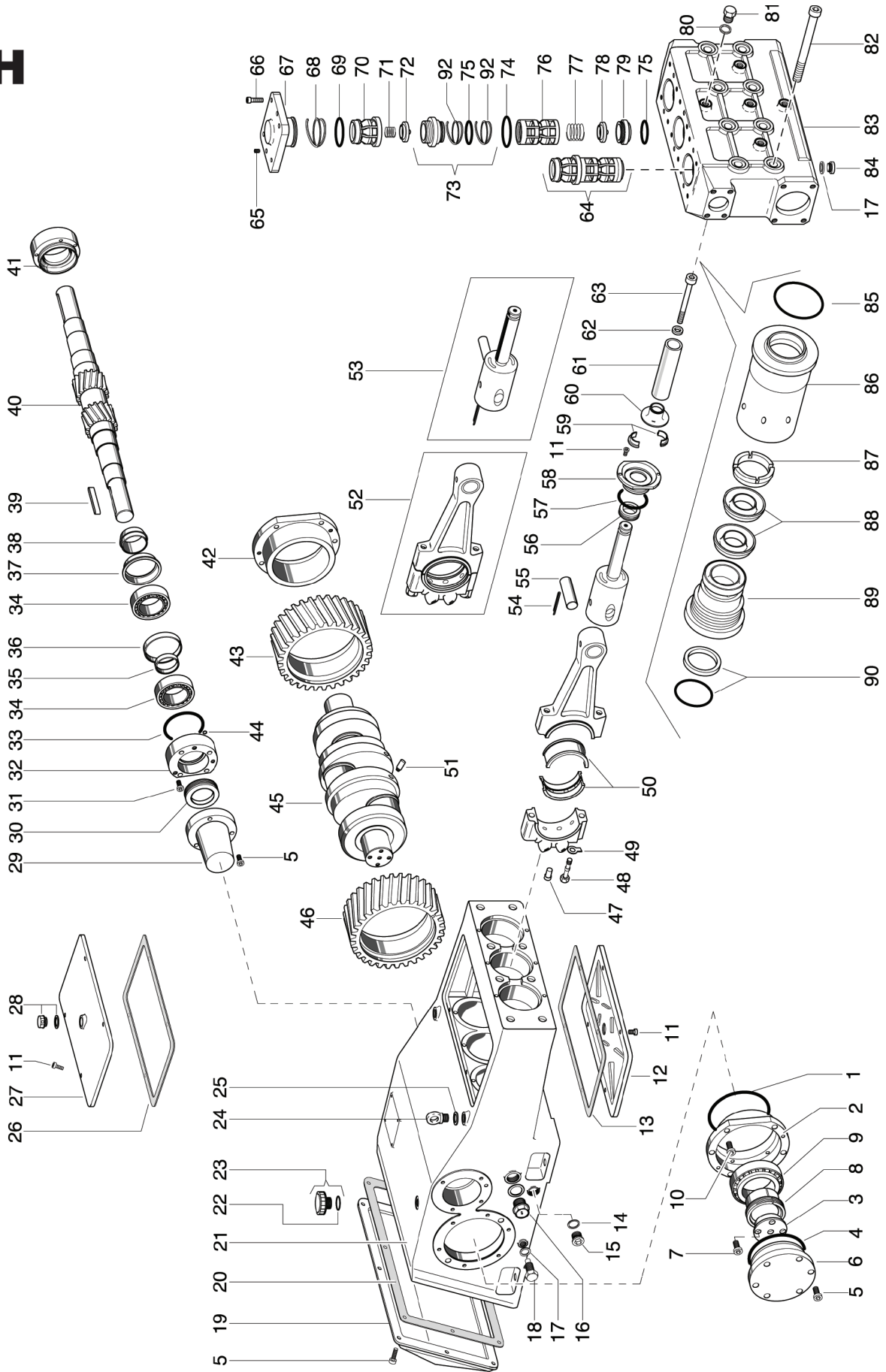

Item	Part #	Description	QTY.
1	F881010133	O-ring, Ø 183.82 x 2.62	2
2	F010100070	Left bearing support	1
3	F030000010	Bearing bushing retainer flange	2
4	F881010132	O-ring, Ø 152.07 x 2.62	2
5	F871121152	Screw, M8 x 20	23
6	F063400280	Bearing cover	2
7	F871131102	Screw, M12 x 25	8
8	F030000020	Bearing bushing	2
9	F811111017	Bearing	2
10	F871125154	Screw, M10 x 30	12
11	F871115152	Screw, M6 x 14	14
12	F040400050	Lower cover	1
13	F080600030	Lower cover gasket	1
14	F872043008	Aluminum washer, Ø 1"	2
15	F821203006	Plug, G 1"	2
16	F801053012	Oil level indicator, G 1"	2
17	F872043002	Aluminum washer, G 1/2"	5
18	F801057002	Magnetic plug, G 1/2"	2
19	F063400240	Back cover	1
20	F080600010	Back cover gasket	1
21	F060100160	Crankcase	1
22	F881010116	O-ring, Ø 29.82 x 2.62	1
23	F801054027	Oil filling plug, G1"	1
24	F872026003	Eye bolt, M16	2
25	F030000030	Eye bolt spacer	2-4
26	F080600020	Upper cover gasket	1
27	F040400030	Upper cover	1
28	F801056002	Venting plug, G1/2"	1
29	F040400070	Crankshaft end cap	1
30	F881080026	Oil seal, Ø 55 x 75 x 10	2
31	F871121154	Screw, M8 x 30	8
32	F036400300	Left bearing cover	1
33	F881010130	O-ring, Ø 94.92 x 2.62	2
34	F811101019	Bearing	4
35	F031000020	Internal bearing spacer	2
36	F031000010	External bearing spacer	2
37	F061000000	Lubricating bushing	2
38	F031000000	Lubricating cone	2
39	F872097013	Pinion key	1
40	F052000020	Pinion, 1500 RPM (Z20)	1
	F052000050	Pinion, 1750 RPM (Z19)	1
	F052000160	Pinion, 1900 RPM (Z18)	1
41	F063400310	Right bearing cover	1
42	F010100080	Right bearing support	1
43	F052000000	Gear, 1500 RPM (Z59, left toothing)	1
	F052000030	Gear, 1750 RPM (Z60, left toothing)	1
	F052000140	Gear, 1900 RPM (Z61, left toothing)	1
44	F881010003	O-ring, Ø 8.73 x 1.78	2
45	F050000060	Crankshaft	1
46	F052000010	Gear, 1500 RPM (Z59, right toothing)	1
	F052000040	Gear, 1750 RPM (Z60, right toothing)	1
	F052000150	Gear, 1900 RPM (Z61, right toothing)	1
47	F034000000	Connecting rod pin	3
48	F035000070	Connecting rod screw	6
49	F872067006	Lock washer, Ø 12	6
50	F023300000	Brass bearing	3
51	F002000000	Crankshaft pin	2
52	F250000030	Connecting rod assembly	3
53	F250001070	Piston assembly	3
54	F872142015	Retainer pin, Ø 5 x 36	3
55	F071000050	Wrist pin, Ø 35	3
56	F881081001	Oil seal, Ø 35 x 47 x 8.5 SP	2
57	F881010128	O-ring, Ø 72.69 x 69 x 2.62	3
58	F063400420	Oil seal cover	1

Item	Part #	Description	QTY.
59	F030000070	Bushing	3
60	F041200010	Flinger washer	3
61	F024201120	Plunger, LHZ/N40	3
	F024201130	Plunger, LHZ/N45	3
	F024201140	Plunger, LHZ/N50	3
	F024201150	Plunger, LHZ/N55	3
	F024201160	Plunger, LHZ/N60	3
62	F881010057	O-ring, Ø 19 x 2	3
63	F035200130	Plunger screw	3
64	F208006210	Valve assembly, LHZ	3
	F208005230	Valve assembly, LHN	3
65	F871125601	Screw, M10 x 16	6
66	F063200070	Screw, M14 x 40 Spec.	12
67	F063200070	Valve cover	3
68	F881112003	Antiextrusion ring	3
69	F881011252	O-ring, Ø 70 x 4 Spec.	3
70	F021200280	Delivery valve guide	3
71	F090200070	Delivery valve spring, LHZ	3
	F090200050	Delivery valve spring, LHN	3
72	F082200080	Delivery valve poppet, LHZ	3
	F082200060	Delivery valve poppet, LHN	3
73	F205000120	Delivery valve seat, LHZ	3
	F205000110	Delivery valve seat, LHN	3
74	F881011168	O-ring, Ø 72 x 3 Spec.	3
75	F881011161	O-ring, Ø 56 x 3 Spec.	6
76	F021200260	Suction valve guide	3
77	F090200060	Suction valve spring, LHZ	3
	F090200040	Suction valve spring, LHN	3
78	F082200070	Suction valve poppet, LHZ	3
	F082200050	Suction valve poppet, LHN	3
79	F081200080	Suction valve seat, LHZ	3
	F081200060	Suction valve seat, LHN	3
80	F881110126	Washer, Ø 3/8"	5
81	F084200470	Plug, G 3/8"	5
82	F035000090	Screw, M20 x 160 Spec.	8
83	F064200180	Manifold	1
84	F821203128	Plug, G 1/2"	3
85	F881011253	O-ring, Ø 72 x 4 Spec.	3
86	F062200140	Cylinder, LHZ/N40	3
	F062200150	Cylinder, LHZ/N45	3
	F062200160	Cylinder, LHZ/N50	3
	F062200260	Cylinder, LHZ/N55	3
	F062200270	Cylinder LHZ/N60	3
87	F031200150	Packing ring, LHZ/N40	3
	F031200160	Packing ring, LHZ/N45	3
	F031200240	Packing ring, LHZ/N50	3
	F031200300	Packing ring, LHZ/N55	3
	F031200310	Packing ring, LHZ/N60	3
88	F881020011	Pressure packing, LHZ/N40	6
	F881020012	Pressure packing, LHZ/N45	6
	F881020014	Pressure packing, LHZ/N50	6
	F881020015	Pressure packing, LHZ/N55	6
	F881020016	Pressure packing, LHZ/N60	6
89	F022300260	Packing support, LHZ/N40	3
	F022300270	Packing support, LHZ/N45	3
	F022300280	Packing support, LHZ/N50	3
	F022300470	Packing support, LHZ/N55	3
	F022300480	Packing support, LHZ/N60	3
90	F881061015	Scraper, LHZ/N40	3
	F881061017	Scraper, LHZ/N45	3
	F881061018	Scraper, LHZ/N50	3
	F881061019	Scraper, LHZ/N55	3
	F881061021	Scraper, LHZ/N60	3
91	F881110127	Washer, Ø 1/2"	3
92	F010500290	Antiextrusion ring	6

REPAIR KITS

Item	LHZ/N40	LHZ/N45	LHZ/n50	LHZ/N55	LHZ/N60
62-85-88-90	F1216	F1217	F1218	F1219	F1220
68-69-74-75-91-92	F1221				
1-4-13-14-17-20-22-26-30-33 44-49-54-56-57-62-68-69-74-75 80-85-88-90-91-92	F1222	F1223	F1224	F1225	F1226

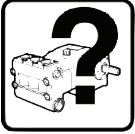

17. TROUBLE SHOOTING



THE PUMP DOES NOT PRODUCE ANY NOISE: the pump is not primed and is running dry!

- No water in the inlet line
- The valves are blocked
- The pressure line is closed and does not allow the air to get out the fluid end.

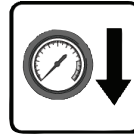

INSUFFICIENT PUMP PRESSURE:

- The nozzle is (or has become) too large.
- RPM are less than rated
- Excessive leakage from pressure packings
- Excessive amount of water by-passed by the pressure regulating valve or faulty valve operation.
- Worn out valves.



THE PUMP KNOCKS:

- Air suction.
- Insufficient feeding:
 - bends, elbows and fittings along the suction line throttle the amount of water which passed through.
 - too small inlet filter.
 - dirty inlet filter.
 - the feeding pump, where provided is not of the suitable type or provides insufficient pressure or volume.
- The pump is not primed due to insufficient feeding or the delivery line is closed during start up.
- The pump is not primed because some valves are stuck (i.e pump inactivity for long time).
- Jammed or worn out valves.
- Worn out pressure packings.
- The pressure regulating valve does not work properly.
- Clearance in the drive system.
- RPM are higher than rated.

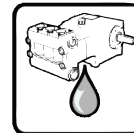

EXCESSIVE WATER LEAKAGE FROM THE PUMP:

- Pressure packing are excessively worn out (due to normal wear or excessive cavitation).
- Worn out plungers

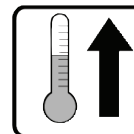

OVERHEATED PUMP:

- The direction of rotation is not correct.
- Pump is overloaded (pressure or RPM over the rated values).
- The oil level is too low or the oil is not of a suitable type or fully used
- Water in the oil
- Excessive belt tension or incorrect alignment of the joint (where provided).
- Excessive inclination of the pump during operation.



THE PUMP DOES NOT DELIVER THE RATED VOLUME:

- Insufficient feeding (due to the cause listed above).
- RPM are less than rated.
- Excessive amount of water by-passed by the pressure regulating valve.
- Worn out valves
- Excessive leakage from pressure packings

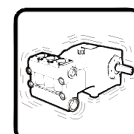

PIPE VIBRATIONS OR KNOCKING:

- Air suction.
- The pressure regulating valve does not work properly.
- The by-pass line is undersized.
- Jammed up valves.
- Drive transmission motion is irregular.

MAINTENANCE LOG

HOURS & DATE

OIL CHANGE							
GREASE							
PACKING REPLACEMENT							
PLUNGER REPLACEMENT							
VALVE REPLACEMENT							



GP Companies, Inc.
1174 Northland Drive
Mendota Heights, MN 55120
Phone: 651.686.2199 Fax: 800.535.1745
www.generalpump.com email: sales@gpcompanies.com

Ref 300018 Rev.C
08/07