

## Owner's Manual

- *Installation*
- *Use*
- *Maintenance*

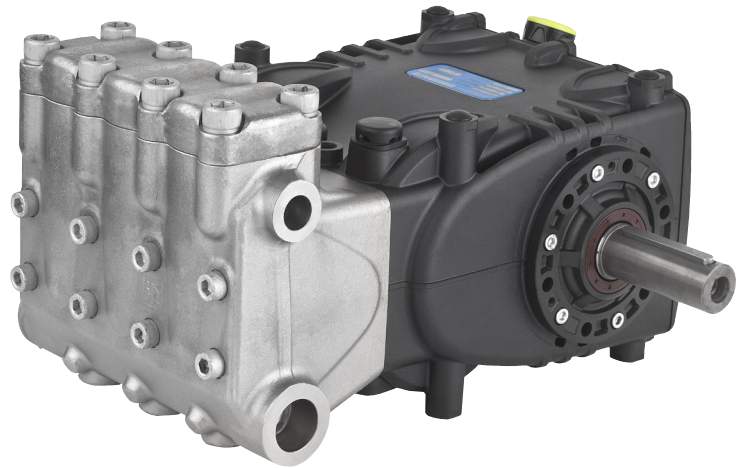

KT16A, KT18A, KT19A, KT20A, KT22A,  
WK525, WK530, WK531



KT24A, KT28A, KT30A, KT32A,  
KT34A, KT36A, KT40A

**INDEX**

<b>1.</b>	<b>INTRODUCTION</b> .....	Page 4
<b>2.</b>	<b>DESCRIPTION OF SYMBOLS</b> .....	Page 4
<b>3.</b>	<b>SAFETY</b> .....	Page 5
	3.1 General safety instructions .....	Page 5
	3.2 High pressure unit safety requirements .....	Page 5
	3.3 Safety during operation .....	Page 5
	3.4 General procedures for using lances .....	Page 5
	3.5 Safety during unit maintenance .....	Page 6
<b>4.</b>	<b>PUMP IDENTIFICATION</b> .....	Page 6
<b>5.</b>	<b>TECHNICAL CHARACTERISTICS</b> .....	Page 7
<b>6.</b>	<b>DIMENSIONS AND WEIGHT</b> .....	Page 8
<b>7.</b>	<b>OPERATING INSTRUCTIONS</b> .....	Page 9
	7.1 Water temperature .....	Page 9
	7.2 Maximum flow and pressure rates .....	Page 9
	7.3 Minimum RPM .....	Page 9
	7.4 Recommended lubricant types and Manufacturers .....	Page 9
<b>8.</b>	<b>PORTS AND CONNECTIONS</b> .....	Page 11
<b>9.</b>	<b>PUMP INSTALLATION</b> .....	Page 12
	9.1 Installation .....	Page 12
	9.2 Direction of rotation .....	Page 13
	9.3 Version change .....	Page 13
	9.4 Hydraulic connections .....	Page 14
	9.5 Pump power supply .....	Page 14
	9.6 Suction line .....	Page 14
	9.7 Filtration .....	Page 15
	9.8 Outlet line .....	Page 16
	9.9 Internal diameter of hose .....	Page 17
	9.10 V-belt transmission .....	Page 19
	9.11 Transmission definition .....	Page 19
	9.12 Definition of static pull to apply on belts .....	Page 21
	9.13 Transmission of power from the second PTO .....	Page 23
<b>10.</b>	<b>START UP AND OPERATION</b> .....	Page 24
	10.1 Preliminary inspections .....	Page 24
	10.2 Starting up .....	Page 24
<b>11.</b>	<b>PREVENTATIVE MAINTENANCE</b> .....	Page 25
<b>12.</b>	<b>PUMP STORAGE</b> .....	Page 26
	12.1 Long-term inactivity .....	Page 26
	12.2 Filling the pump with anti-corrosion emulsion or anti-freeze .....	Page 26

**INDEX**

13.	PRECAUTIONS AGAINST FREEZING.....	Page 26
14.	WARRANTY TERMS.....	Page 26
15.	TROUBLESHOOTING.....	Page 27
16.	EXPLODED VIEWS AND PARTS.....	Page 28
17.	FLUSHING CIRCUIT DIAGRAM.....	Page 33
18.	MAINTENANCE LOG.....	Page 34

## 1. INTRODUCTION

This manual describes the use and maintenance instructions of the KT/WK Series pump, and should be carefully read and understood before using the pump.

Correct use and adequate maintenance will guarantee the pumps trouble-free operation for a long time. General Pump declines any responsibility for damage caused by misuse or the non-observance of the instructions indicated in this manual.

Upon receiving the pump, check that it is complete and in perfect condition. Should anything be found out of order, please contact us before installing and starting the pump.

## 2. SYMBOL DESCRIPTIONS



**Warning**  
Potential Danger

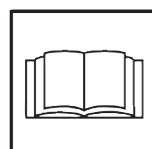

**Danger**  
High Voltage



**Danger**  
Wear protective mask



**Danger**  
Wear goggles



**Danger**  
Wear protective gloves



**Danger**  
Wear protective boots



**Symbol for protection against explosion.**

This defines special safety requirements for the use of the pumps in areas identified in accordance with the ATEX Directive.

**When pumps are ordered in the ATEX configuration** because they are going to work in areas with a potentially explosive environment, you must STRICTLY comply with the notes given under the headings marked with this symbol and the instructions in the supplementary instructions manual “**ATEX EXPLOSION PROTECTION**”.

### 3. SAFETY

#### 3.1 General Safety Indications

Improper use of pumps and high pressure systems, and the non-compliance with installation and maintenance instructions may cause severe injury to people and/or damage to property. Anyone assembling or using high pressure systems must possess the necessary competence to do so, should be aware of the characteristics of the components assembled/used, and must take all precautions necessary to ensure maximum safety in any operating condition. In the interest of safety, both for the Installer and the Operator, no reasonably applicable precaution should be omitted.

#### 3.2 High pressure unit safety requirements

1. The pressure line must always be equipped with a safety valve.
2. High pressure system components, in particular for those units working outside, must be adequately protected against rain, frost and heat.
3. The electrical control system must be adequately protected from water spray, and must comply with the specific regulations in force.
4. High pressure hoses must be properly sized for maximum operating pressure of the system and always and only used within the operating pressure range specified by the hose manufacturer. The same rules should be observed for all other auxiliary systems affected by high pressure.
5. The ends of high pressure hoses must be sheathed and secured to a solid structure to prevent dangerous whiplash in case of bursting or broken connections.
6. Appropriate safety guards must be provided for the pump transmission systems (couplings, pulleys and belts, auxiliary drives).



#### 3.3 Safety During Operation

The working area of a high pressure system must be clearly marked. Access must be prohibited to un-authorized personnel and, wherever possible, the area should be restricted or fenced. The personnel authorized to access this area should first be trained, and informed about the risks that may arise from failures or malfunctions of the high pressure unit.

Before starting the unit, the operator must check:

1. That the high pressure system is properly powered (see paragraph 9.5).
2. That pump intake filters are perfectly clean; we advise the use of a device that indicates the filters clogging level.
3. Electrical parts are adequately protected and in perfect condition.
4. The high pressure hoses do not show apparent signs of abrasion, and that fittings are in perfect shape.
5. In relation to the application, use and environmental conditions, during the operation the outer surfaces of the pump may reach high temperatures. Therefore we recommend to take precautions to avoid contact with hot parts.

Any fault or reasonable doubt that may arise before or during operation should be promptly reported and verified by competent personnel. In these cases, pressure should immediately be released and the high pressure system stopped.



#### 3.4 General Procedures For Using Nozzles

1. The Operator must always place his own and other worker's safety before any other interest; his and should always be governed by good sense and responsibility.
2. The Operator must always wear a helmet with a protective visor, waterproof clothing, and appropriate boots capable of guaranteeing grip on wet pavement.

*Note: appropriate clothing will effectively protect against water spray, but it may not offer adequate protection against the direct impact of water jets or sprays from a close distance. Some circumstances may require further protection.*

3. It is generally best to organize personnel into teams of at least two people capable of giving mutual and immediate assistance in case of necessity and of taking turns during long and demanding operation.
4. Access to the work area that is within the water jets' range must be absolutely prohibited to and free from objects that, inadvertently under a pressure jet, can be damaged and or create dangerous situations.
5. The water jet must only and always be directed in the direction of the work area, including during testing or preliminary tests or checks..
6. The Operator must always pay attention to the trajectory of the debris removed by the water jet. If necessary, suitable guards must be provided by the Operator to protect anything that may be accidentally exposed.
7. The Operator should not be distracted for any reason during operation. Workers needing to access the operating area must wait for the Operator to stop work, and then immediately make their presence known.
8. For safety reasons, it is important that each member of the team is fully aware of the intentions and actions of other team members in order to avoid dangerous misunderstandings.
9. The high pressure system must not be started up and run under pressure without all team members in position and without the Operator having already directed his/her lance toward the work area.

### 3.5 Safety During System Maintenance

1. The pressure system maintenance must be carried out in the time intervals set by the manufacturer who is responsible for the whole group according to law.
2. Maintenance should always be carried out by trained and authorized personnel.
3. Assembly and disassembly of the pump and its various components must be performed exclusively by authorized personnel, using appropriate equipment in order to avoid damage to components and connections.
4. Always use original spare parts to ensure total reliability and safety.

## 4. PUMP IDENTIFICATION

Each pump has a specific label which contains:

- Pump model and version
- Serial Number
- Flow Rate - GPM
- Pressure - PSI
- Power - Hp-kW
- Maximum RPM



**Pump model, version and serial number must always be specified when ordering spare parts.**



**For pumps ordered with the ATEX configuration.**  
**Pos. 3 plate with specific ATEX marking for explosion protection.**  
**Pos. 4 plate for locating the grounding screw.**

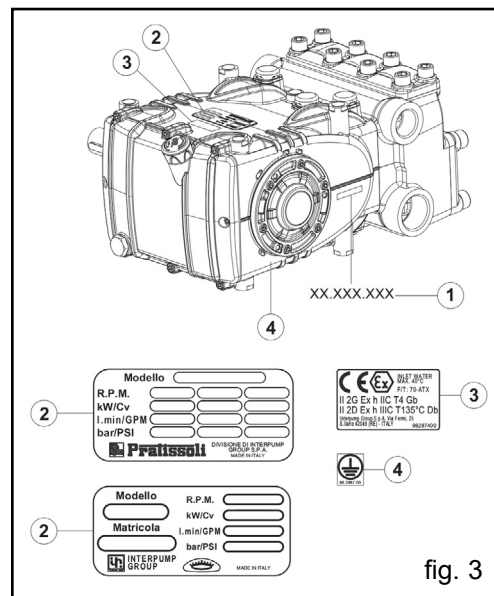

fig. 3

**5. TECHNICAL FEATURES**

MODEL	RPM	FLOW RATE		PRESSURE		POWER	
		GPM	l/min	PSI	Bar	Hp	kW
KT16A	1750	7.1	27.4	7,250	500	35.6	26.2
KT18A	1750	9.2	34.7	5,800	400	36.1	26.5
KT19A	1450	7.9	30	7,250	500	38.5	28.7
	1750	9.5	36	5,800	400	37.4	27.9
KT20A	1450	9.4	35.5	5,800	400	36.3	27.1
	1750	11.4	42.9	4,650	320	35.6	26.2
KT22A	1450	11.4	43	4,640	320	35.3	26.3
	1750	13.7	51.9	3,630	250	33.7	24.8
KT24A	1750	16.4	61.7	2,900	200	32.1	23.6
KT28A	1750	22.2	84.0	2,540	175	38.2	28.0
KT30A	1750	25.4	96.4	2,175	140	35.1	25.8
KT32A	1750	29.1	110.0	1,750	150	35.4	26.0
KT34A	1450	27.21	103.0	2175	150	40.0	29.4
KT36A	1580	33.1	125.4	1,813	125	40.7	29.9
KT40A	1450	37.5	142.1	1,450	100	36.9	27.1
WK525	1450	5.8	22	7,240	500	28.2	21.03
WK530	1450	7.7	29	7,240	500	37.7	27.73
WK531	1450	7.9	30	7,240	500	39	28.7

## 6. DIMENSIONS AND WEIGHT

For dimensions and weight of KT16A, KT18A, KT19A, KT20A, KT22A, WK525, WK530, WK531 please refer to fig. 2.

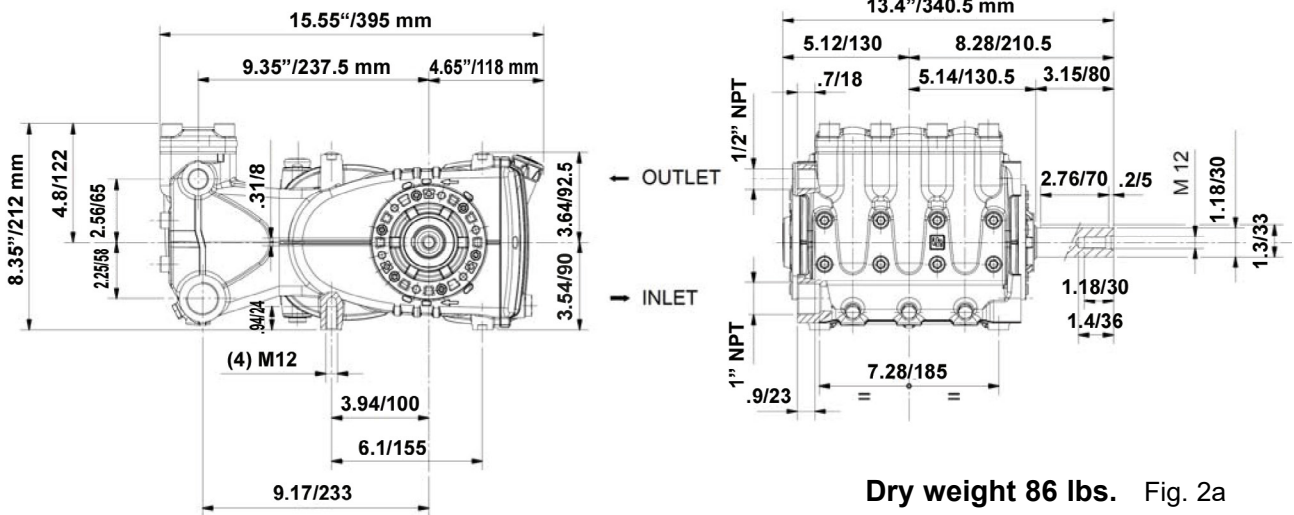

For dimensions and weight of KT24A, KT28A, KT30K, KT32A, pumps, please refer to fig. 2a.

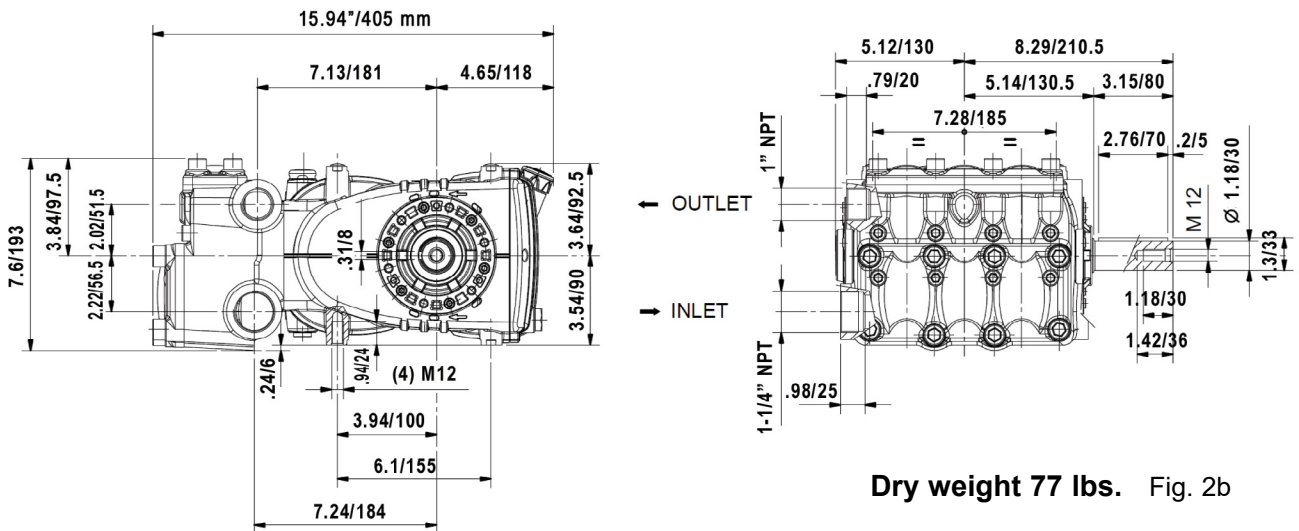

For dimensions and weight of KT34A, KT36A, KT40A pumps, please refer to fig. 2b.

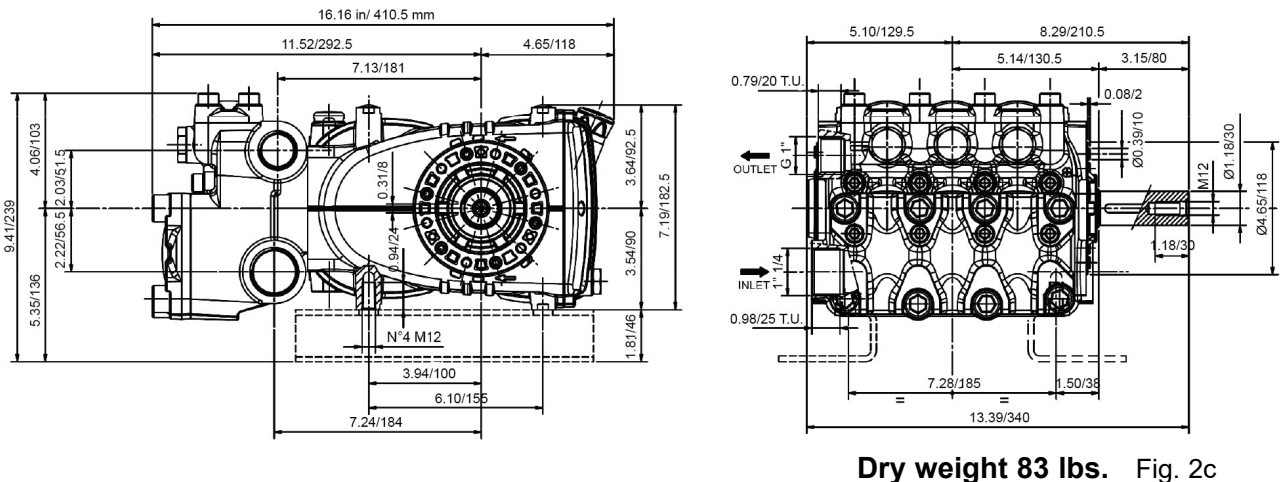



## 7. OPERATING INSTRUCTIONS



The KT/WK pump was designed to operate with filtered water (see paragraph 9.7), in environments that are not potentially explosive and at maximum temperature of 104° F (40° C).

**Other fluids may be used only upon the approval of The Customer Service Department .**



### 7.1 WaterTemperature

The max water temperature is 104° F (40° C). However, it is possible to use the pump at temperatures of up to 140° F (60° C) for short periods of time. In this case we advise consulting the Customer Service Department.

### 7.2 Max Flow Rate and Pressure Values

The performance values indicated in the catalog refer to the maximum performance of the pump. Regardless of the power used, pressure and maximum RPM values indicated on the plate may not be exceeded unless expressly authorized by the **Customer Service Department**.

### 7.3 Lowest RPM

Any RPM value different from what is indicated in the performance table (see chapter 5) must be expressly authorized by the **Customer Service Department**.

### 7.4 Recommended Lubricant Oil Types & Manufacturers

The pump is delivered with lubricant oil compliant with room temperatures ranging between 32° and 89.6° F (0° and 30° C). Some recommended lubricant types are indicated in the table below; these lubricants are treated with additives in order to increase corrosion protection and resistance to fatigue. As an alternative, Automotive SAE 85W-90 gearing lubricants may also be used.

BRAND	TYPE
<b>GENERAL PUMP</b>	<b>SERIES 220</b>
ARAL	Aral Degol BG220
BP	ENERGOL HLP 220
CASTROL	Hyspin VG 220, Magna 220
ELF	POLYTELIS 220
ESSO	NUTO 220
FINA	Cirkan 220
FUCHS	RENOLIN 220
MOBIL	DTE OIL BB
SHELL	TELLUS C 220
TEXACO	RANDO HD 220
TOTAL	CORTIS 220

Check the oil level by using the oil level dipstick (1), fig. 3. Refill if necessary to top off level. Correct oil level inspection is done with the pump at room temperature; oil is changed with the pump at working temperature, by removing the oil dipstick (2), fig 3, and then the drain plug (3), fig. 3.

Checking and changing oil is to be carried out as indicated in the table in fig. 14, Chapter 11. The amount required is 304 oz. (2 liters).

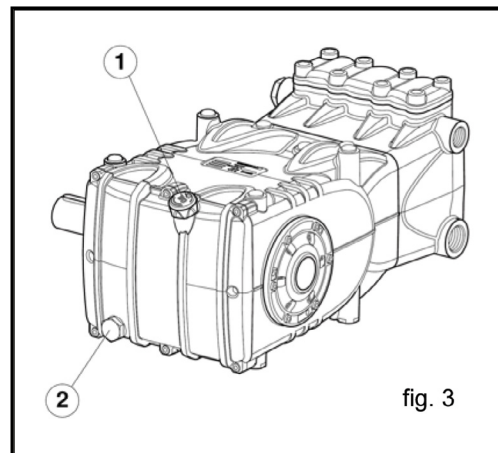

fig. 3



Set up the system so that the oil temperature does not exceed in any case 212 °F (100 °C) during pump operation.

Use a temperature probe in the oil drain plug pos. 2 Fig. 3.

See "ATEX EXPLOSION PROTECTION" manual.

**ATTENTION:** Use only oil with a flash point higher than 212 °F (200 °C).



In any case, oil must be changed at least once a year since it may deteriorate by oxidation.

For room temperatures that differ from that mentioned earlier, follow the indications contained in the diagram below, keeping in mind that the oil must have a minimum viscosity of 180 cSt.

### VISCOSITY/ROOM TEMPERATURE DIAGRAM

### Viscosity / Room temperature Diagram

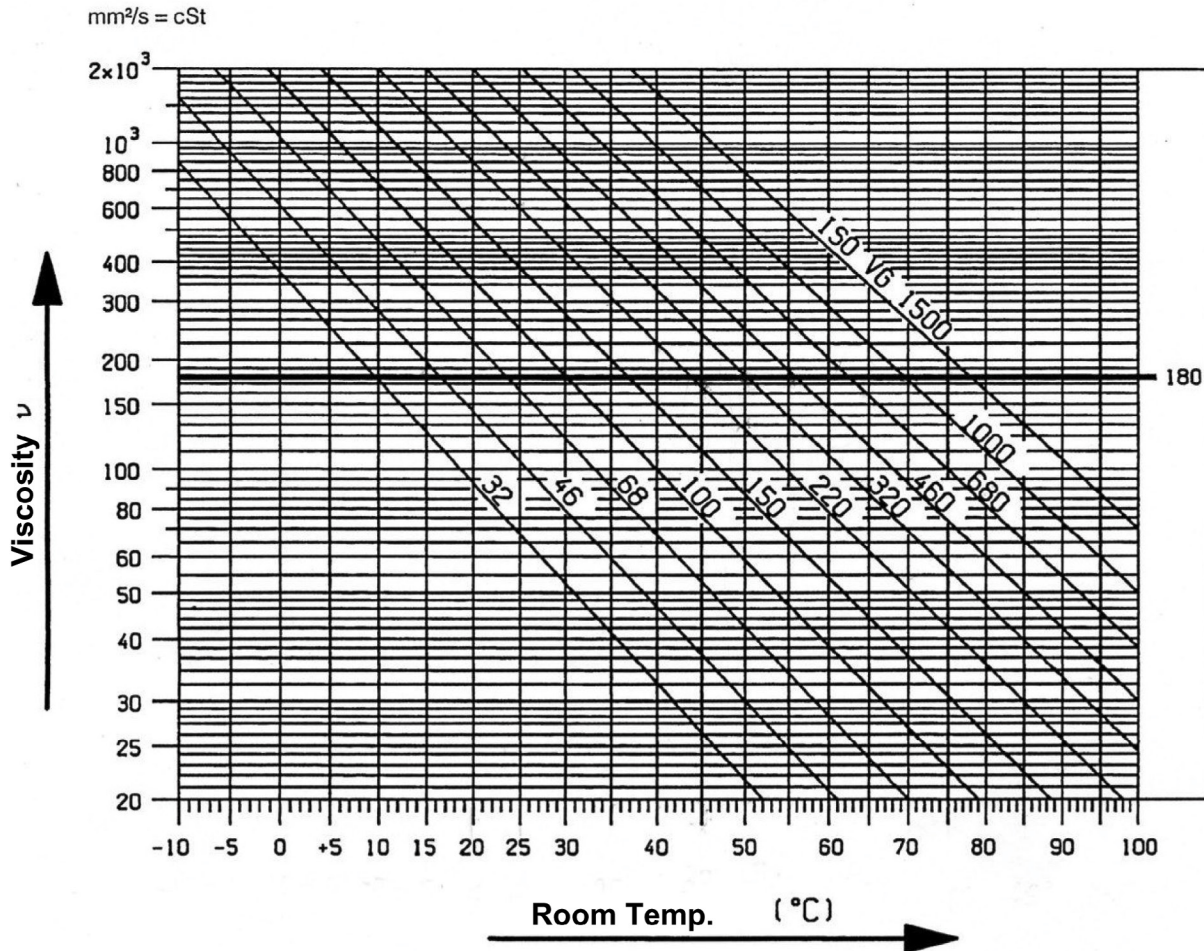

Exhausted oil must be collected in an appropriate recipient and disposed of in appropriate locations. In absolutely no case may it be dispersed into the environment.

## 8. PORTS AND CONNECTIONS

KT Series pumps are equipped with (see fig. 4):

1. 2 inlet ports "IN", 1" NPT (Fig. 4, KT16A, KT18A, KT19A, KT20A, KT22A, WK525, WK530, WK531).  
2 inlet ports "IN", 1-1/4" NPT (Fig. 4a, KT24A, KT28A, KT30A, KT34A, KT36A, KT36A, KT40A).

Line connection to any of the two ports is indifferent for proper pump functioning. The unused ports must be sealed off.

2. 2 outlet ports "OUT", 1/2" NPT-F (Fig. 4, KT16A, KT18A, KT19A, KT20A, KT22A, WK525, WK530, WK531).  
2 outlet ports "OUT", 1" NPT-F (Fig. 4a, KT24A, KT28A, KT30A, KY34A, KT36A, KT36A, KT40A).

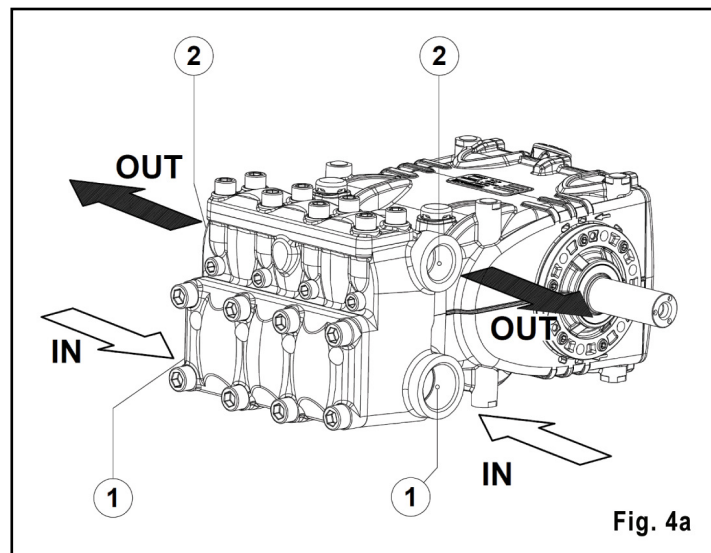
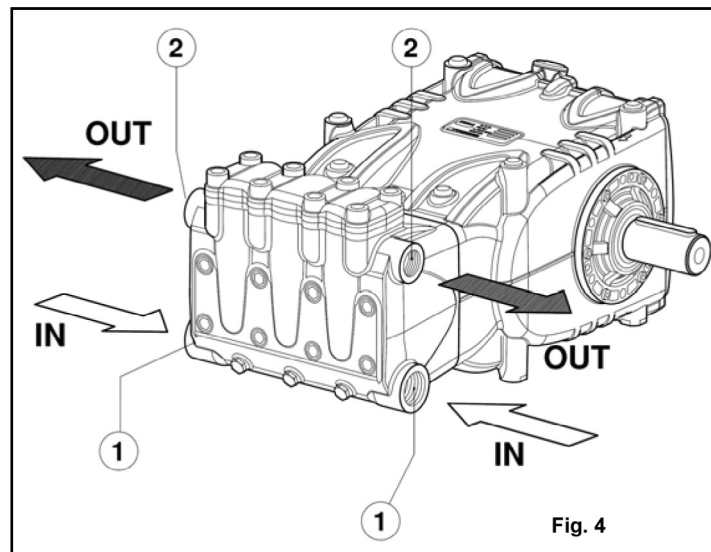

## 9. PUMP INSTALLATION

### 9.1 Installation

The pump must be installed in a horizontal position using the M12x1.5 threaded support feet. Tighten the screws with a torque of 80 Nm (59 Ft-Lb)

The base must be perfectly flat and rigid enough as not to allow bending or misalignment on the pump coupling and axis/transmission due to torque transmitted during operation.

The unit cannot be fixed rigidly to the floor. For special applications contact the **Customer Service Department**.

A lifting bracket is mounted on the pump for easy installation, as per the figure below.



**Grounding:** the pump must be connected to an grounding conductor using the stainless steel M6 screw and stainless steel serrated washer marked with a YELLOW label. See “**ATEX EXPLOSION PROTECTION**” manual.



**Replace the oil filling hole closing service plug (red) positioned on the rear casing cover with the plug with oil dipstick. Check the correct quantity.**

The dipstick must always be reachable, even when the unit is assembled.



**The pump's shaft (PTO) must not be rigidly connected to the motor unit.**

The following transmission types are suggested:

- Hydraulics by flange, for proper application consult with the Customer Service Department
- Flexible joint
- Cardan Joint (please respect the maximum working angles indicated by the manufacturer)
- V-belt

### 9.2 Direction of rotation

The PTO rotation is indicated by an arrow located on the casing near the drive shaft. From a position facing the pump head, the rotation direction will be as in fig. 5.

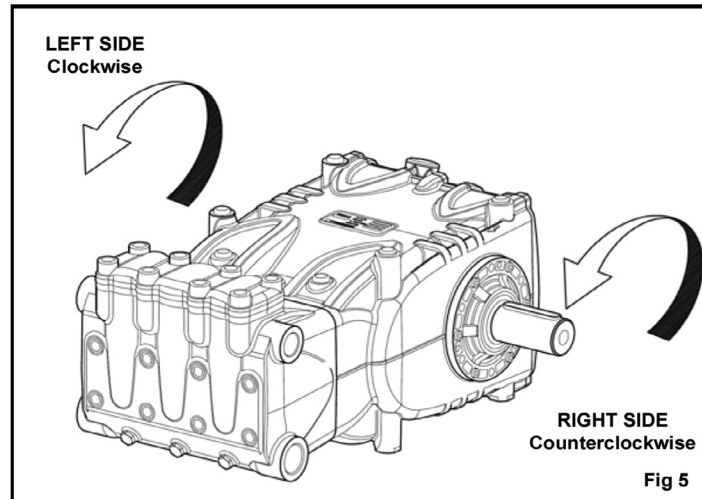

### 9.3 Version Change and Reducer Positioning

A right version pump is defined when: observing the pump from the head side, the PTO shank of the pump shaft is on the right side.

A left version pump is defined when: observing the pump from the head side, the PTO shank is on the left side. See fig. 5.



**The version may be changed only by trained and authorized personnel by carefully following the instructions in the repair manual.**

1. Separate the manifold from the power end (crankcase) as indicated in Chapter 2 in point 2.2.1 of the Repair Manual.
2. Turn the power end (crankcase) 180° and reposition the rear casing cover in such a way that the oil dipstick is turned upward. Reposition the lifting bracket and relative hole closing plugs in the upper part of the casing. Finally, properly reposition the specification label in its housing on the casing.



**Make sure that the lower inspection cover draining holes are open.**

3. Reassemble the manifold with the power end (crankcase) as indicated in Chapter 2 in point 2.2.5 of the Repair Manual.

#### 9.4 Hydraulic Connections

In order to isolate the system from the vibrations produced by the pump, we advise to build the first section of the duct near the pump (both for intake and delivery) with flexible hose. The consistency of the intake section must be as such to avoid deformation caused by vacuums produced by the pump.

#### 9.5 Pump Power Supply

A positive head of at least 8 inches (.2 meters) is required for the best volumetric efficiency.

#### 9.6 Suction Line

For the pump's correct operation, the suction line must have the following characteristics:

1. Minimum internal diameter as indicated in the diagram in paragraph 9.9, and in any case equal or greater than the pump head's value. Along the duct, avoid localized diameter reductions that may cause pressure drops with subsequent cavitation. Absolutely avoid 90° elbows, connections with other hoses, bottlenecks, counter-slopes, upside down "U" shaped curves, "T" connections.
- 
2. With a layout that is set in such a way to prevent cavitation.
  3. It should be perfectly airtight, and built in a way that guarantees perfect sealing over time.
  4. Avoid pump emptying when stopping (even partial emptying).
  5. Do not use hydraulic fittings, 3 or 4 way fittings, adapters, etc., since they may hinder the pump's performance.
  6. Do not install Venturi tubes or injectors for detergent intake.
  7. Avoid the use of standing valves, check valves, or any other type of one-way valves.
  8. Do not connect the by-pass line from the valve directly to the pump suction line.
  9. Provide appropriate baffle plates inside the tank in order to avoid water flows coming from both the by-pass and feeding which lines may create turbulence near the tank's outlet port.
  10. Make sure that the suction line is perfectly clean inside before connecting it to the pump.

## 9.7 Filtering

On the suction line, install two filters as indicated in fig. 7 and fig. 7/a.

With the manual adjustment valve:

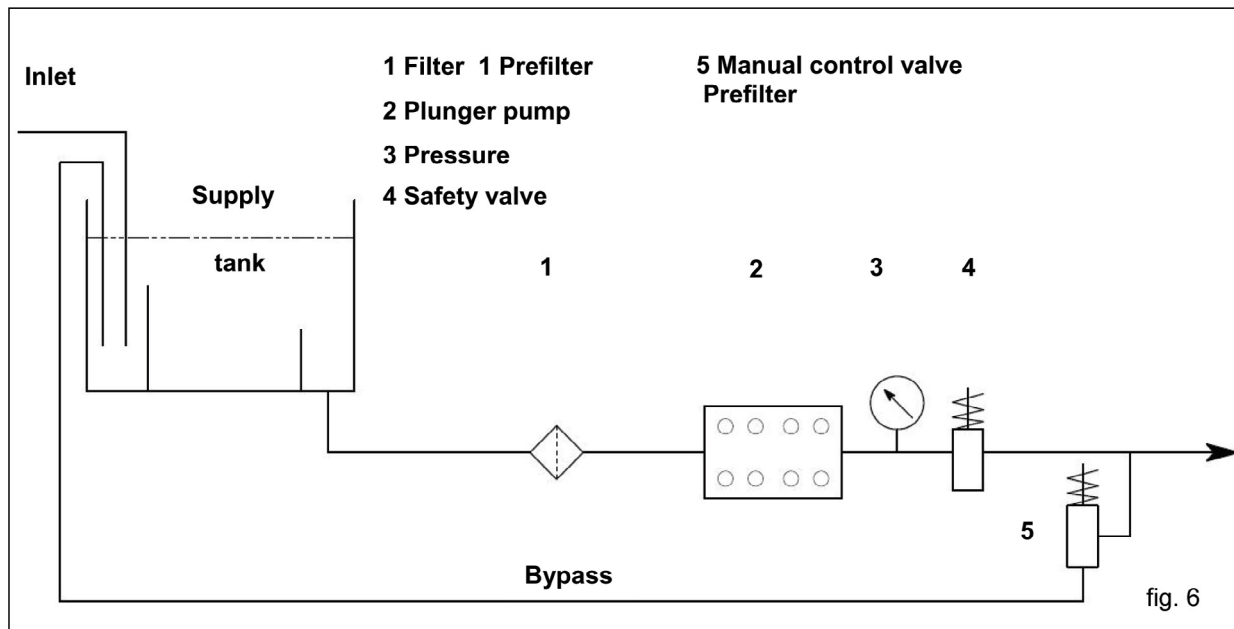

With a pneumatically activated control valve

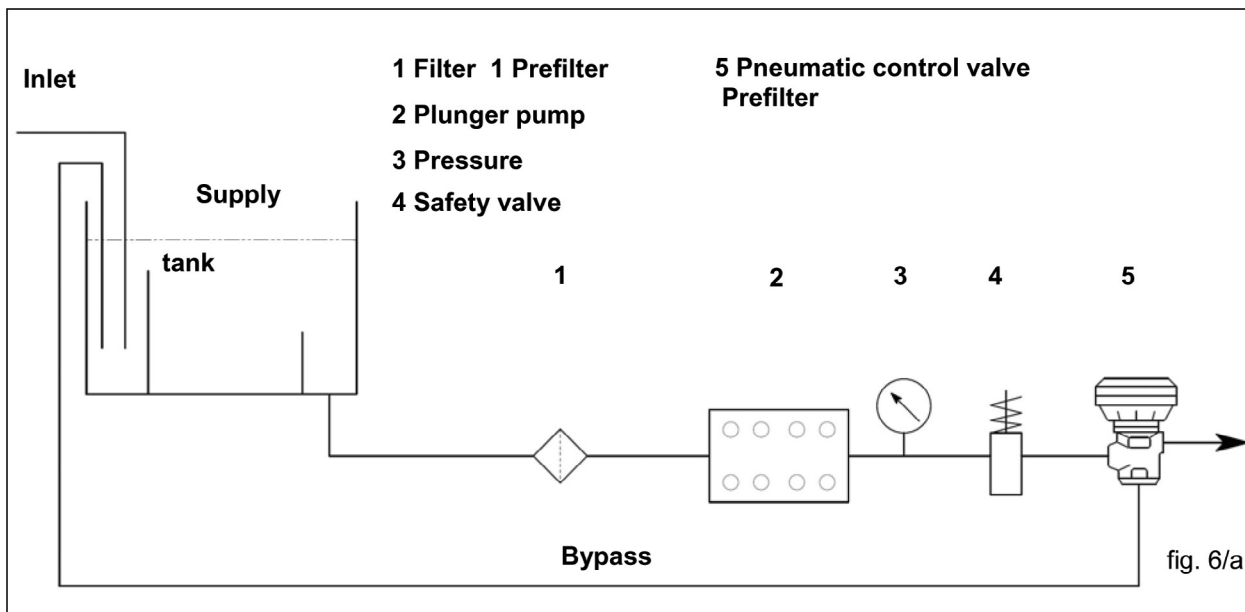

The filter must be installed as close as possible to the pump, should allow easy inspection and have the following characteristics:

1. Minimum capacity 3 times greater than the pump's rated flow value.
2. Filter port diameters must not be smaller than the pump inlet ports.
3. Filtration degree ranging between 200 and 360  $\mu\text{m}$ .



**In order to guarantee correct pump operation, it is important to plan periodical cleaning of the filter depending on actual pump usage, water quality and actual clogging conditions.**

**9.8 Outlet Line**

To obtain a correct delivery line, please comply with the following installation instructions:

1. The internal diameter of the hose must allow to guarantee correct fluid speed; see diagram in paragraph 9.9
2. The first section of the hose connected to the pump must be flexible in order to isolate pump vibrations from the rest of the system.
3. Use high pressure hoses and fittings that guarantee wide safety margins in any working condition.
4. Install a safety valve on the delivery line.
5. Use pressure switches suitable for the pulsating loads typical of plunger pumps.
6. In the design phase, take into proper account the pressure drop along the line, since this causes a reduction in usage pressure with respect to the value measured at the pump.
7. If the pump pulsations are harmful for particular applications, install an appropriately sized pulsation dampener on the outlet line.



FOR KT16A, KT18A, KT19A, KT20A, KT22A, WK525, WK530, WK531:

### 9.9 Internal Diameter of the Hose Line

To determine the internal diameter of the hose, please refer to the following diagram.

#### Suction Hose

With a flow rate of ~105 GPM (400 l/mn) and water speed of 1 m/sec. the diagram line that connects the two scales intersects the central scale, indicating the diameters, at a value of ~ 3.5 inch (90 mm).

#### Delivery Hose

With a flow rate of ~105 GPM (400 l/mn) and water speed of 5.5 m/sec. The diagram line that connects the two scales intersects the central scale, indicating the diameters at a value of ~ 1.6 inch (40 mm).

#### Optimal speed to be obtained with the booster pump:

- Suction: ≤ 1 m/sec.
- Delivery: ≤ 5.5 m/sec.

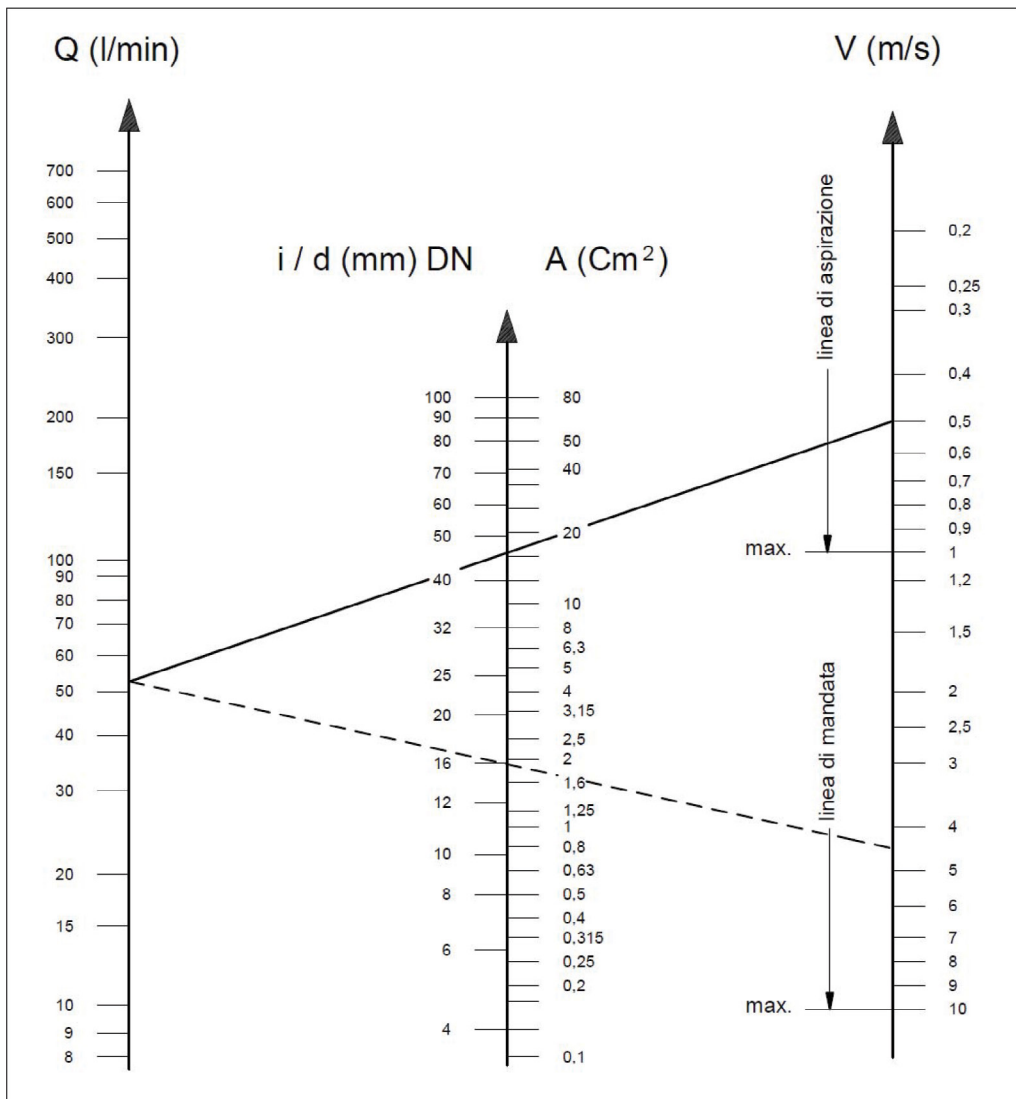

The diagram does not take into account the hose and valve resistance, the pressure drop due to the pipe length, the viscosity and the temperature of the pumped fluid. If necessary, contact our **Customer Service Department**.

FOR KT24A, KT28A, KT30A, KT32A, KT34A, KT36A, KT40A:

### 9.9 Internal Diameter of the Hose Line

To determine the internal diameter of the hose, please refer to the following diagram.

#### Suction Hose

With a flow rate of ~105 GPM (400 l/mn) and water speed of 1 m/sec. the diagram line that connects the two scales intersects the central scale, indicating the diameters, at a value of ~ 3.5 inch (90 mm).

#### Delivery Hose

With a flow rate of ~105 GPM (400 l/mn) and water speed of 5.5 m/sec. The diagram line that connects the two scales intersects the central scale, indicating the diameters at a value of ~ 1.6 inch (40 mm).

#### Optimal speed to be obtained with the booster pump:

- Suction: ≤ 1 m/sec.
- Delivery: ≤ 5.5 m/sec.

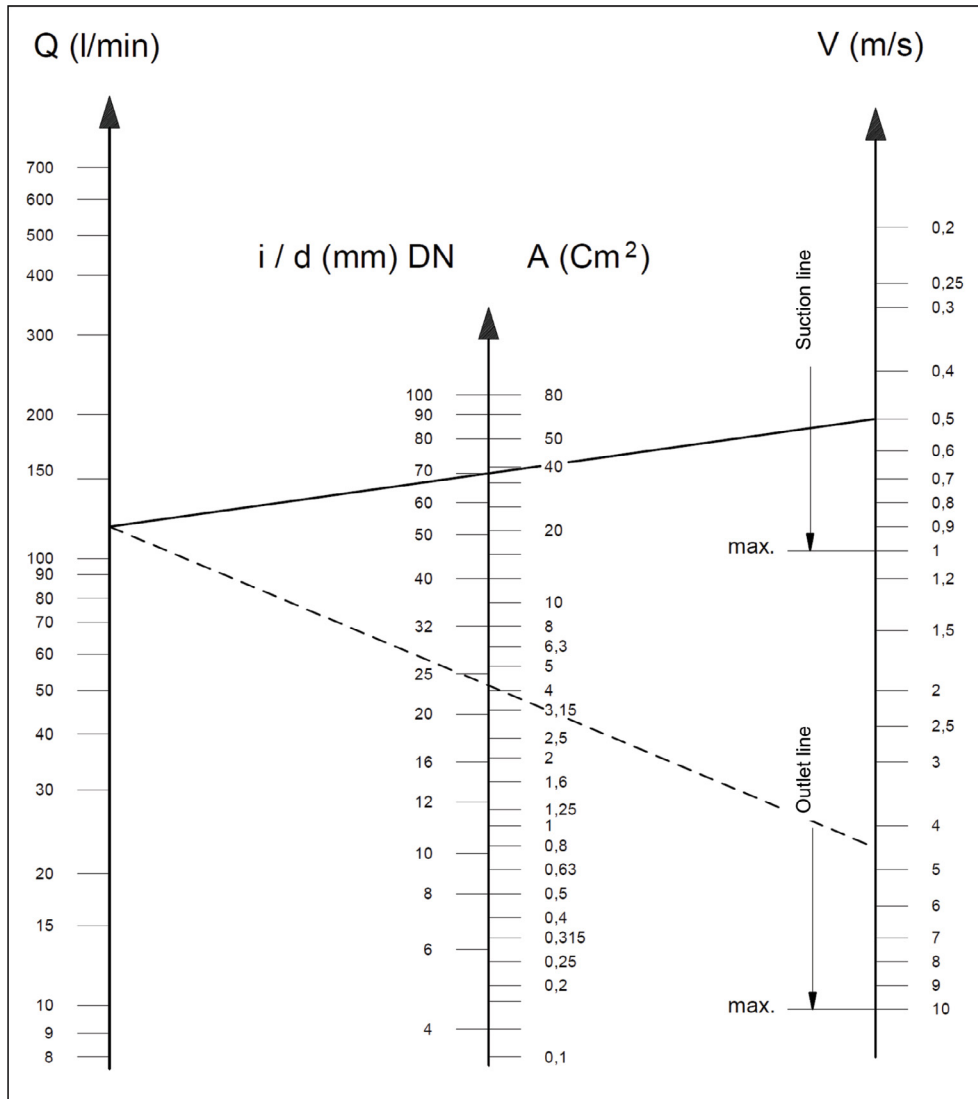

The diagram does not take into account the hose and valve resistance, the pressure drop due to the pipe length, the viscosity and the temperature of the pumped fluid. If necessary, contact our **Customer Service Department**.

### 9.10 V-belt Transmission

The pump can be controlled by a v-belt system. For these pumps we recommend use of 3 XPB belts (16.5x13 serrated). Use an XPC profile only for long durations. Both the characteristics and transmissible power of each belt can be verified in the diagram in fig. 7, in relation to the number of RM normally declared by the manufacturer.

Minimum duct pulley diameter (on pump shaft):  $\geq 6.3''$  (160 mm).

The radial load on the shaft must not exceed 4500 N (value necessary for Layout definition). The transmission is considered adequate if the load is applied to a maximum distance  $a=50$  mm from the shaft shoulder (PTO) as shown in fig. 10.



For dimensions differing from those specified above, contact our **Customer Service Department**.

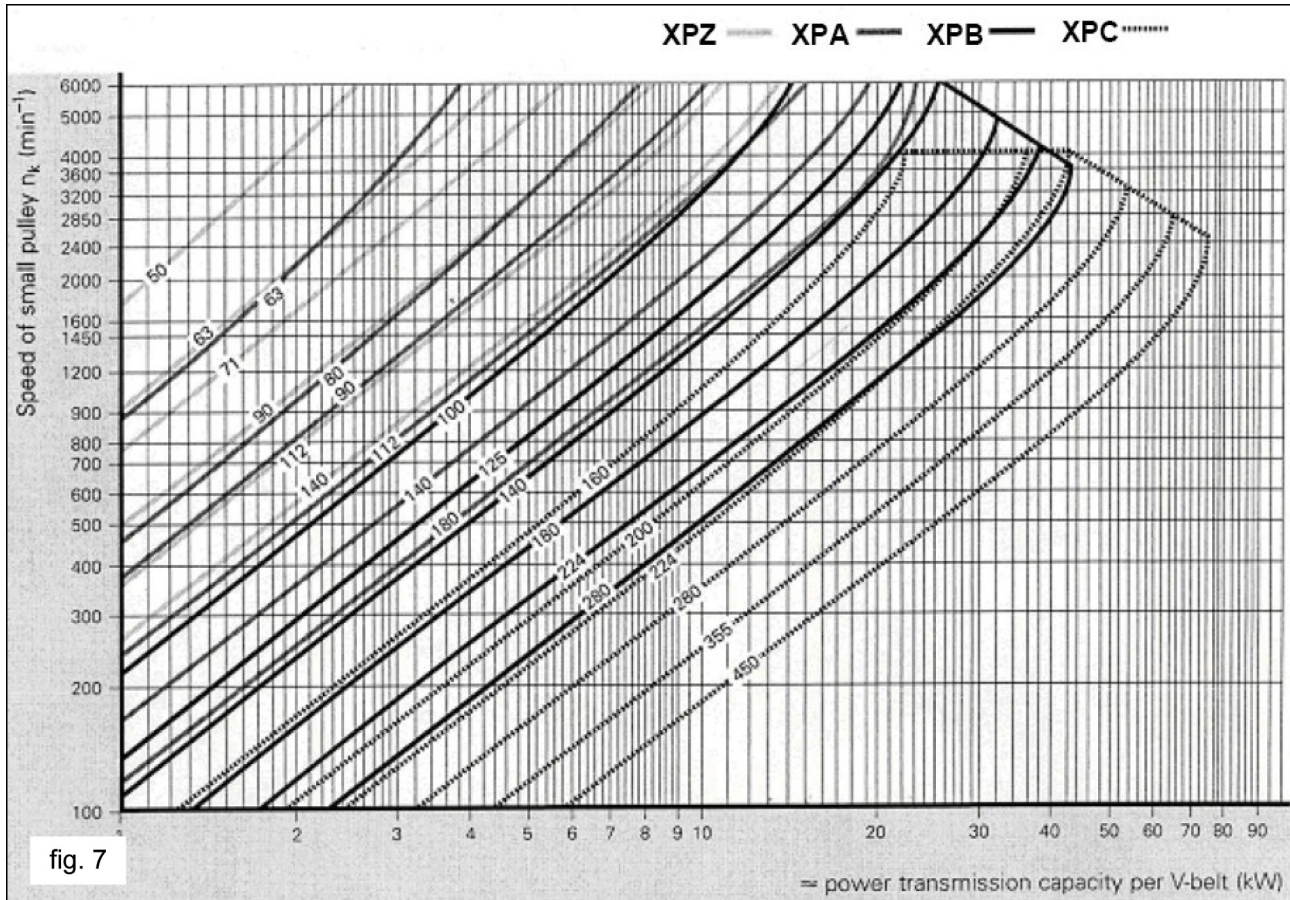

fig. 7

= power transmission capacity per V-belt (kW)

### 9.11 Transmission Definition

To prevent irregular radial loads on the shaft and the relative bearing, follow these directions:

- a) Use pulleys with v-belts with the size of the groove required/recommended by the manufacturer of belt used. In the absence of directions, follow fig. 8 and the table in fig. 9

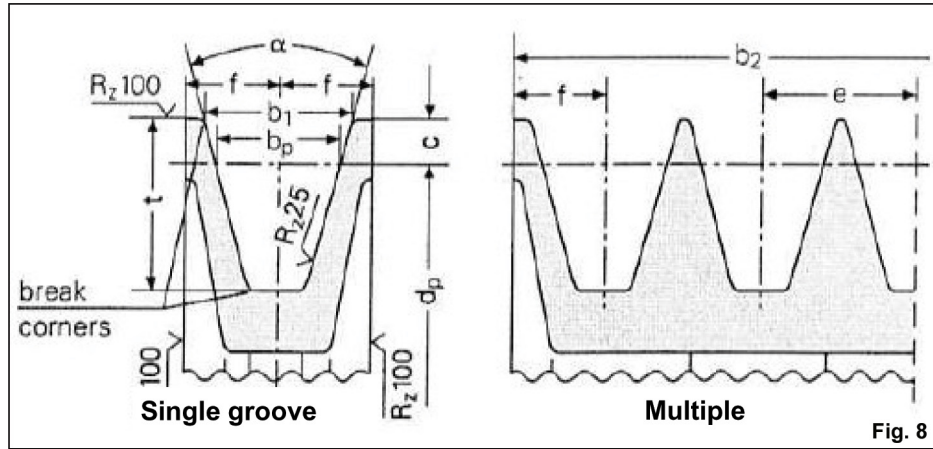

Dimensions (in mm)

Belt section as per DIN 7753 part 1 and B.S. 3790		DIN symbol symbol B.S./ISO	XPB/SPB SPB	XPC/SPC SPC	
Belt section as per DIN 2215 and B.S. 3790		DIN symbol symbol B.S./ISO	17 B	22 C	
Pitch width		$b_w$	14.0	19.0	
Increased grooving width $b_1 \approx$		$\alpha = 34^\circ$	18.9	26.3	
		$\alpha = 38^\circ$	19.5	27.3	
		c	8.0	12.0	
Distance between grooving		e	$23 \pm 0.4$	$31 \pm 0.5$	
		f	$14.5 \pm 0.8$	$20.0 \pm 1.0$	
Increased grooving depth $t_{min}$			22.5	31.5	
$\alpha$	34°	by primitive diameter narrow-section v-belts DIN 7753 part 1	$d_w$	from 140 to 190	from 224 to 315
	38°			> 190	> 315
$\alpha$	34°	by primitive diameter classic section v-belts DIN 2215	$d_w$	from 112 to 190	from 180 to 315
	38°			> 190	> 315
Tolerance for $\alpha = 34^\circ - 38^\circ$			$\pm 1^\circ$	$\pm 30'$	
Pulleys for $b_2$ by grooving number z $b_2 = (z-1)e + 2f$  Minimum pulley diameter must be respected. Do not use laminated v-belts.			1	29	40
			2	52	71
			3	75	102
			4	98	133
			5	121	164
			6	144	195
			7	167	226
			8	190	257
			9	213	288
			10	236	319
			11	259	350
			12	282	381

Fig. 9

b) Use high performance belts - for example XPB instead of SPB - as a lower quality of belts for the same transmitted power may be necessary and a consequent shorter resulting distance compared to the shaft shoulder (PTO), "a" of fig. 10.

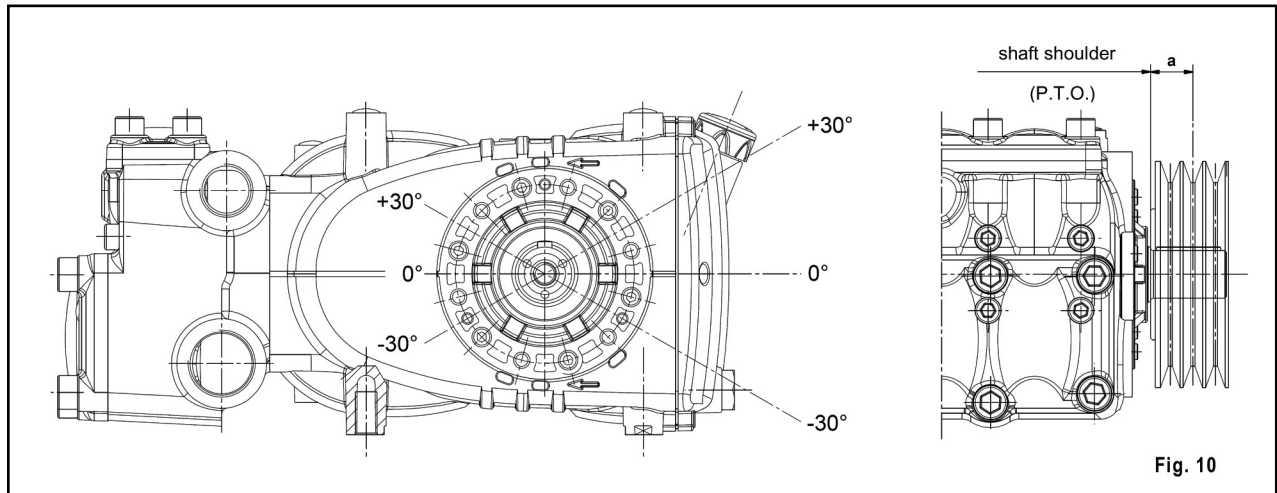

- c) Pull the belts according to manufacturer instructions. Excessive pulling can cause reduced bearing life and wear out the pulley prematurely. Pulling depends on different variables as indicated in point 9.12.
- d) Belt length has a natural tolerance  $\geq \pm 0.75\%$ . For this reason, the 3 belts must be purchased as a pair.
- e) Follow the direction of the belt pull as shown in fig. 10; for other needs, contact our **Customer Service Department**.
- f) Take care of the alignment of the driving pulley and driven pulley grooves.

### 9.12 Definition of static pull to apply on belts

Static pull depends on:

- a) The wheelbase between the two pulleys (belt length)
- b) The load due to static pull of the belt
- c) The number of belts
- d) The winding angle of the smallest pulley
- e) Average speed
- f) etc.

Values of the static pull to be applied can be obtained from the diagram in fig. 11 for belts with a XPB profile in relation to the wheelbase.

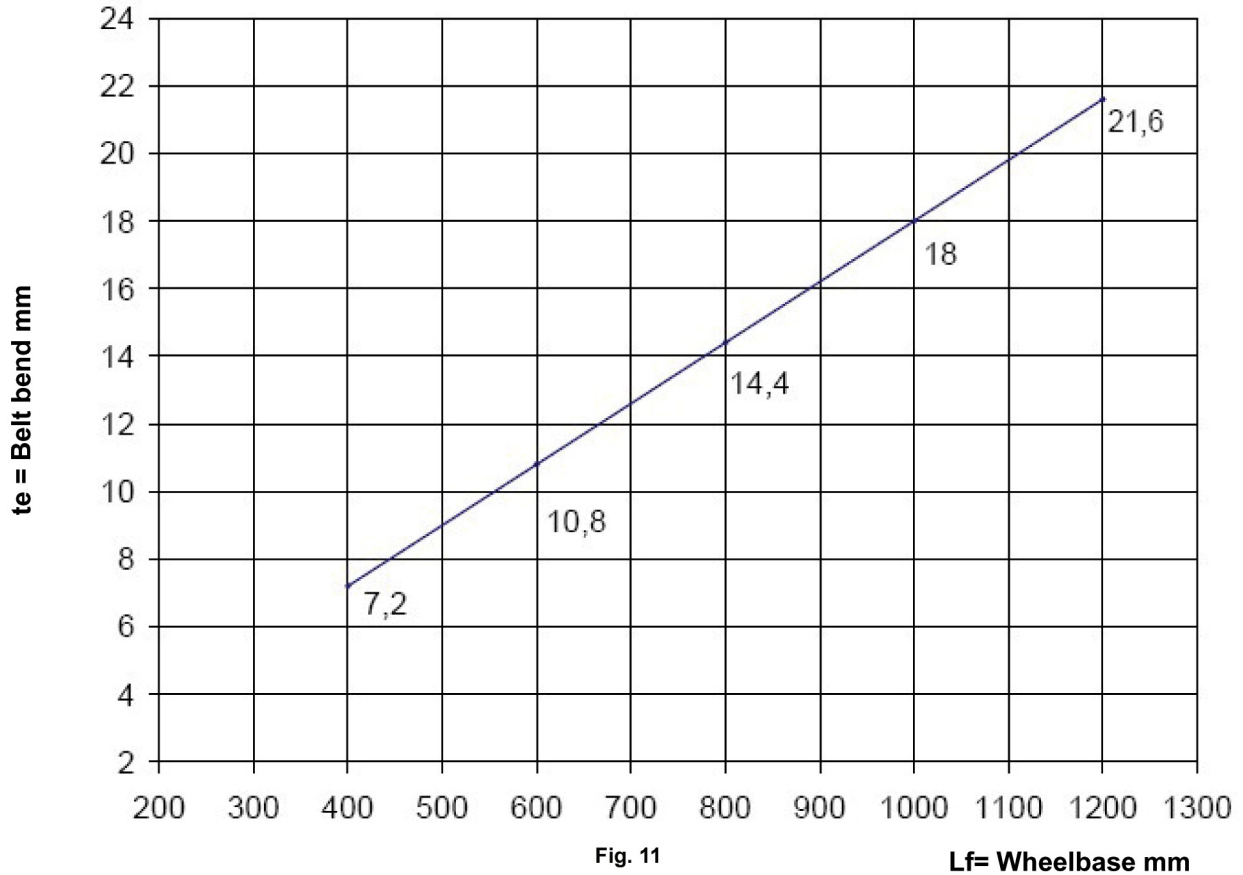

Fig. 11

Lf= Wheelbase mm

Conclusion: with a wheelbase of 600 mm and with a dynamo-meter, loading the belt branch with 75 N as indicated in fig. 12, a “te” bend of approximately 10.8 mm is obtained.

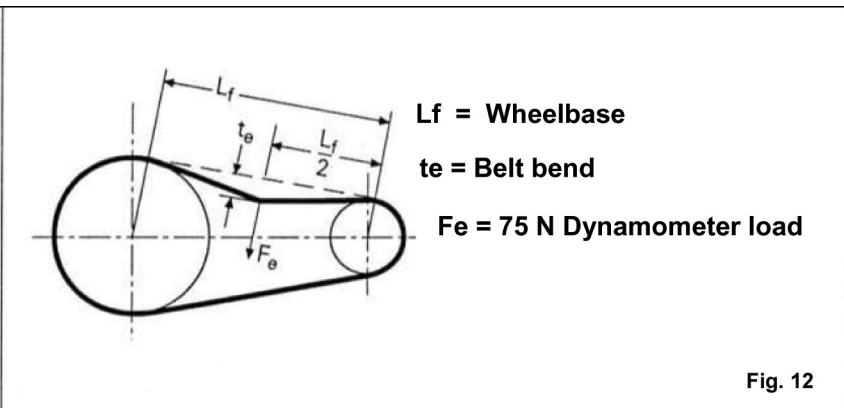
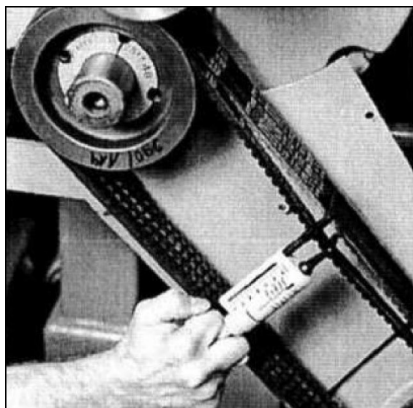

Fig. 12

Note: unless otherwise state by the supplier of he belts, control of proper pull and its relative re-tensioning should be performed after no less than 30 minutes of motion necessary for the normal adjustment of the belts. Best performance and durability will be achieved with proper tensioning.

Note2: In case of necessity or for routing maintenance, never replace a single belt but the complete set.

## 9.13 Transmission of power from the second PTO

Upon request, KT/WK pumps can be supplied with auxiliary PT on the side opposite of the drive (Transmission of power from the second PTO).

Transmission can be carried out:

- By means of the V belts
- By means of the joint

By means of the V-belt, with drawable Max Torque is:  
15 ft. lbs (20 Nm) which corresponds to:

- 4.1 Cv to 1450 RPM
- 5.0 Cv to 1750 RPM

By means of the joint, with drawable Max Torque is:  
30 ft. lbs. (40 Nm) which corresponds to:

- 8.2 Cv to 1450 RPM
- 10 Cv to 1750 RPM



By means of the V-belt, the transmission is considered suitable if:  
Belt pull is applied at a max distance of .7" (18 mm) from the bend shaft shoulder (see fig. 13). Min. diameter pulley to be used =  $\varnothing$  4" (100 mm).



With transmission by means of the joint, pay particular attention to perfect alignment so that no transverse forces are generated on the pump shaft.

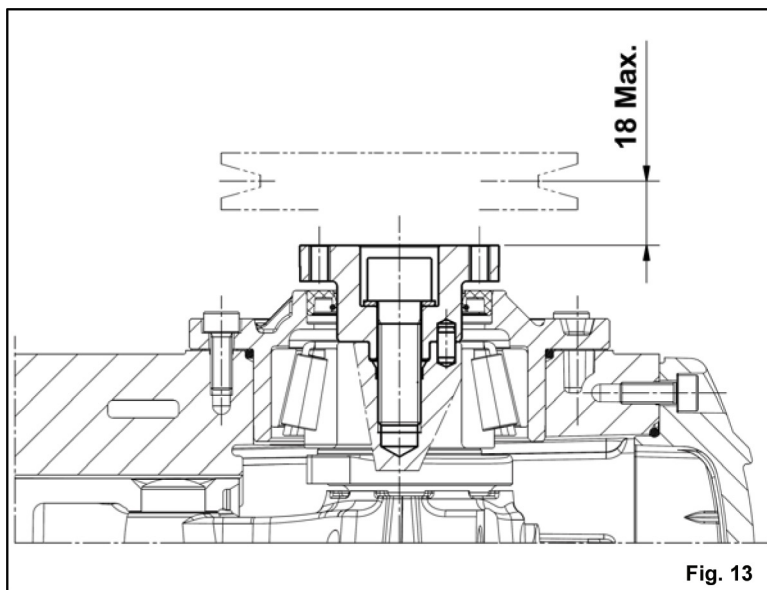

For applications differing from those specified above, contact our **Customer Service Department**.

## 10. START-UP AND OPERATION

### 10.1 Preliminary Inspections

Before Start-up Be sure that:



**The suction line is connected and up to pressure (see Chapter 9) the pump must never run dry.**

1. The suction line must be perfectly airtight.
2. All the On-Off valves between the pump and the feeding source are completely open. The delivery line must discharge freely in order to allow the air in the pump to be ex-pulsed easily, thus facilitating pump priming.
3. All suction/delivery connections and fittings must be correctly tightened.
4. Coupling tolerances on the pump/transmission axis (half-joint misalignment, Cardan tilt, belt tightening, etc.) must remain within the limits indicated by the transmission Manufacturer.
5. The pump's oil level must be verified using the correct dipsticks (position 1, fig 14) and visually verified with the level indicator (2, fig. 14).

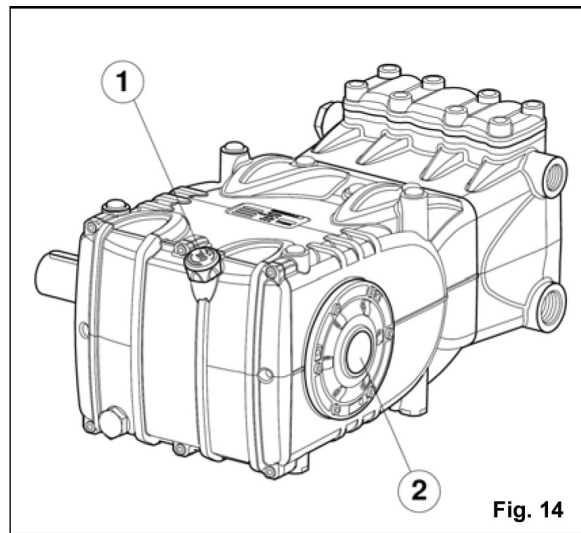

Fig. 14



**In case the pump has not run for a long period of time, check proper functioning of the suction and outlet valves.**

### 10.2 Start-up

1. When starting the pump for the first time, check for the correct direction of rotation.
2. The pump must be started off-load.
3. Verify correct feeding pressure.
4. During operation, check that the rotating speed does not exceed the rated value.
5. Before putting the pump under pressure let it run for at least 3 minutes.
6. Before stopping the pump, release the pressure using the control valve or any pressure relieving device and reduce to a minimum RPM.



**11. PREVENTATIVE MAINTENANCE**

To guarantee pump reliability and efficiency, comply with the maintenance intervals as indicated in the table below.

<b>PREVENTATIVE MAINTENANCE</b>	
<b>EVERY 500 HOURS</b>	<b>EVERY 1000 HOURS</b>
Check oil level	Change oil
	Check / Replace:* <ul style="list-style-type: none"><li>• Valves</li><li>• Valve seats</li><li>• Valve springs</li><li>• Valve guides</li></ul>
	Check / Replace: <ul style="list-style-type: none"><li>• H.P packings</li><li>• L.P. packings</li></ul>



**ATTENTION: Replace the bearings and the related seal rings every 2000 hours of operation.**

Perform periodical checks on cleaning and maintenance on the pump. See "ATEX EXPLOSION PROTECTION" manual.

\* For replacement follow instructions contained in the repair manual.

## 12. PUMP STORAGE

### 12.1 Long-term Inactivity

If the pump is started for the first time after a long period from the date of shipment, before operation, check the oil level, inspect the valves as specified in Chapter 10, then follow described star-up procedures.

### 12.1 Filling the Pump With An Anti-Corrosion Emulsion or Anti-freeze By Using An External Diaphragm Pump As In The Layout Shown in Paragraph 9.7.

- In place of the service tank, use a suitable container containing the solution to be pumped.
- Close the filter drainage, if open.
- Make sure that the hoses to be used are clean inside and spread grease on their connections.
- Connect the high pressure exhaust hose to the pump
- Connect the suction hose to the diaphragm pump
- Connect the suction hose between the pump head and the diaphragm pump.
- Fill the service container with solution.
- Insert the free ends of the suction hose and the high pressure exhaust hose inside the container.
- Switch on the diaphragm pump.
- Pump the solution until it exits from the high pressure hose.
- Continue pumping for at least another minute.
- Stop the pump and remove the previously connected hoses.
- Clean, grease and plug the connections on the pump head.

The characteristics of the solution can be strengthened if necessary by adding, for example, Shell Donax.

## 13. PRECAUTIONS AGAINST FREEZING



In areas and periods of the year where there is risk of freezing, follow the instructions indicated in Chapter 12.



**In the presence of ice, in no case must the pump be started until the entire circuit has been completely thawed out; not complying with this indication may cause serious damage to the pump.**

## 14. WARRANTY TERMS

The pump is guaranteed for a period of 5 years from the delivery date, with the exception of parts subject to wear. In any case, please refer to the contract terms for other warranty conditions. The warranty is void if:

- a) The pump has been used for purposes that differ from that agreed.
- b) The pump has been fit with an electric or diesel engine with performance greater than that indicated in the table.
- c) The required safety devices were un-adjusted or disconnected.
- d) The pump was used with accessories or spare parts not supplied by General Pump.
- e) Damage was caused by:
  - 1) improper use
  - 2) the non-observance of maintenance instructions
  - 3) use not compliant with operating instructions
  - 4) insufficient flow rate
  - 5) faulty installation
  - 6) incorrect positioning or sizing of the hoses
  - 7) non-authorized design changes
  - 8) cavitation

**15. TROUBLESHOOTING****The pump does not produce any noise at start-up:**

- The pump is not primed and is running dry
- There is no water in the inlet line
- The valves are blocked
- The delivery line is closed and does not allow the air in the pump to be discharged

**The pump pulses irregularly (knocking):**

- Air suction
- Insufficient feeding
- Bends, elbows, fittings along the suction line obstruct the fluid's passage
- The inlet filter is dirty or too small
- The booster pump, where provided, supplies insufficient pressure or flow rate
- The pump is not primed due to insufficient head or the delivery line is closed during priming
- The pump is not primed due to valve seizing
- Worn valves
- Worn pressure packings
- Incorrect operation of the pressure adjustment valve
- Transmission problems

**The pump does not deliver the rated flow / is noisy:**

- Insufficient feeding (see the causes listed above)
- RPM are less than the rated flow
- Excessive amount of water by-passed by the pressure adjustment valve



- Worn valves
- Leakage from the pressure packings
- Cavitation due to:
  - 1) Wrong sizing of the suction hose/undersized diameters
  - 2) Insufficient flow rate
  - 3) High water temperature

**Insufficient pump pressure:**

- The nozzle (or has become) too large
- Insufficient RPM
- Leakage from the pressure packings
- Incorrect operation of the pressure adjustment valve
- Worn valves

**Overheated pump:**

- The pump is overloaded (pressure or RPM exceed the rated values)
- Oil level is too low, or the oil is not of a suitable type, indicated in Chapter 7 (see paragraph 7.4)
- Incorrect alignment of the joint or pulleys
- Excessive inclination of the pump during operation

**Pump vibrations or knocking:**

- Air suction
- Incorrect operation of the pressure adjustment valve
- Valve malfunction
- Irregular drive transmission motion

**16. EXPLODED VIEW AND PARTS LIST**

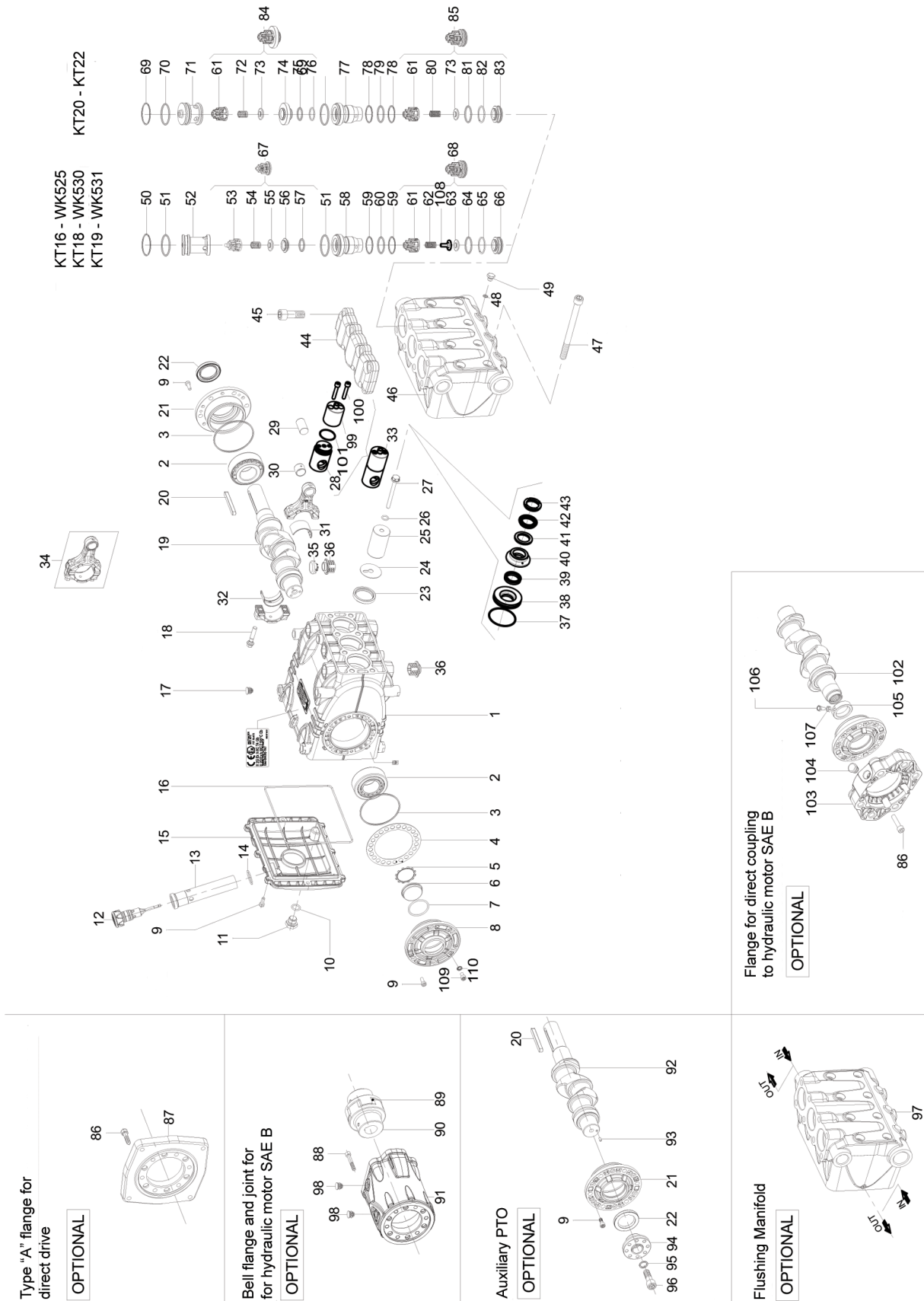

# GENERAL PUMP

A member of the Interpump Group

# KT16A/18A/19A/20A/22A, WK525/530/531 SERIES

Item	Part #	Description	QTY.
1	F70010022	Crankcase	1
2	F91847700	Tapered Roller Bearing	2
3	F90391500	O-ring, Ø 80.60x2.62	2
4	F70220081	Shim, 0.1 mm	1
	F70220381	Shim, 0.25 mm	
5	F90075600	Retainer Clip	1
6	F70211801	Oil Site Glass	1
7	F90387700	O-ring, Ø 39.34x2.62	1
8	F70150122	Bearing Cover (Oil Glass Side)	1
9	F99185400	Screw, M6x16	20
10	F90383300	O-ring, Ø 13.95x2.62	1
11	F98210050	Plug, G3/8x13 TE22	1
12	F98211500	OIL DIPSTICK D.21,5X70	1
13	F72210695	DIP STICK TUBE	1
14	F90360400	O-ring, Ø25.12x1.78	1
15	F70160622	CRANKCASE COVER	1
16	F90394200	OR Ø 190.17X2.62 NBR 70SH	1
17	F98200500	PLUG Ø 15	5
18	F99312300	CONN.ROD BOLT M8X1X42	6
19	F70020635	CRANKSHAFT	1
20	F91490000	KEY	1
21	F70150022	BEARING COVER (PTO SIDE)	1
22	F90166800	OIL SEAL Ø 35X52X7	1
23	F90167700	OIL SEAL Ø 36X47X7	3
24	F96709900	WASHER Ø 10X45	3
25	F70040009	PLUNGER Ø 20X62	3
	F70040109	PLUNGER Ø 22X62	
	F70041009	PLUNGER Ø 16X63	
	F70041109	PLUNGER Ø 18X63	
	F70041809	PLUNGER Ø 19X63	
26	F90358400	O-RING Ø 10,82X1,78(2043)90SH	3
27	F70224136	PLUNGER BOLT	3
28	F70050015	PLUNGER GUIDE	3
29	F97742000	GUDGEON PIN Ø 18X36	3
30	F90910000	CONNECTING ROD BUSHING	3
31	F90922000	UPPER HALF-BUSH (BIG END)	3
	F90922100	UPPER HALF-BUSH (BIG END), +0.25	
	F90922200	UPPER HALF-BUSH (BIG END), +0.50	
32	F90922300	LOWER HALF-BUSH (BIG END)	3
	F90922400	LOWER HALF-BUSH (BIG END), +0.25	
	F90922500	LOWER HALF-BUSH (BIG END), +0.50	
34	F70030501	CONNECTING ROD COMPLETE	3
35	F71225951	PLUG CAP	3
36	F70222551	CRANKCASE PLUG	6
37	F90362600	O-RING Ø 50,52X1,78	3
38	F70081766	PACKING RETAINER Ø 16	3
	F70081866	PACKING RETAINER Ø 18	
	F70082366	PACKING RETAINER Ø 19	
	F70081966	PACKING RETAINER Ø 20	
	F70082066	PACKING RETAINER Ø 22	
39	F90263100	L.P. SEAL Ø 16X24X6.5	3
	F90268800	L.P. SEAL Ø 20X28X5.5	
	F90271300	L.P. SEAL Ø 22X30X5.5	
	F90264800	L.P. SEAL Ø 18X26X5.5	
	F90266200	L.P. SEAL Ø 19X27X5.4	
40	F70224566	INTERMEDIATE RING Ø 16	3
	F70224666	INTERMEDIATE RING Ø 18	
	F70227766	INTERMEDIATE RING Ø 19	
	F70224766	INTERMEDIATE RING Ø 20	
	F70224866	INTERMEDIATE RING Ø 22	
41	F90268700	RESTOP RING, 26X32X6.2/3	3
	F90264000	RESTOP RING, 16X30X6.2/3	
	F90270400	RESTOP RING, 20X35X5.5/2	
	F90273000	RESTOP RING, 22X35X5.5/2	
	F90266000	RESTOP RING, 19X32X6.0/3	
42	F90270500	PACKING 20x35x7,5,HP	3
	F90272500	PACKING 22x35x7/4.5, HP	
	F90268600	PACKING 18X32X7/4.5 HP	
	F90264200	PACKING 16X30X7/4.5, HP	
	F90266100	PACKING 19X32X7.1/4.5, HP	
43	F70100051	HEAD RING Ø 20	3
	F70100151	HEAD RING Ø 22	
	F70100651	HEAD RING Ø 19	
	F71100051	HEAD RING Ø 18	
	F47100351	HEAD RING Ø 16	

Item	Part #	Description	QTY.
44	F70224036	VALVE COVER	1
45	F99485000	SCREW M14X40 UNI5931	8
46	F70125836	MANIFOLD FOR PIST. Ø 16, NPT	1
	F70125936	MANIFOLD FOR PIST. Ø 18, NPT	
	F70125636	MANIFOLD FOR PIST. Ø 18, BSP	
	F70125936	MANIFOLD FOR PIST. Ø 19, NPT	
	F70125636	MANIFOLD FOR PIST. Ø 19, BSP	
	F70126036	MANIFOLD FOR PIST. Ø 20-22, NPT	
47	F99382800	SCREW M10X140 5931	8
48	F90357600	O-RING 6.75X1.78	3
49	F98197200	PLUG G1/8X8 S.S.	3
50	F90517750	ANTI-EXTRUSION RING, Ø 30.9X35X1.5, KT16,18,19	3
51	F90386600	O-RING Ø 29,82X2,62 90 SH., KT16,18,19	6
52	F70224366	VALVE PLUG Ø 35, KT16,18,19	3
53	F36202551	VALVE CAGE, KT16,18,19	3
54	F94737600	SPRING Ø 9.4X14.8, KT16,18,19	3
55	F36203266	SPHERICAL VALVE, KT16,18,19	3
56	F36200366	VALVE SEAT, KT16,18,19	3
57	701115	O-RING Ø 17.13X2.62, KT16,18,19	3
58	F70224266	VALVE SPACER, KT16,18,19	3
59	F90516500	ANTI-EXTR.RING Ø 24.7x29x1.5, KT16,18,19	6
60	F90385800	O-RING Ø 23.81X2.62 NBR 90SH, KT16,18,19	3
61	F36210305	VALVE CAGE S.S.	3
62	F94739700	SPRING Ø 11.4X20, KT16,18,19	3
63	F36205066	SPHERICAL INLET VALVE, KT16,18,19	3
64	F90385600	O-RING Ø .23,47X2,62(3093) 90SH., KT16,18,19	3
65	F90515500	ANTI-EXTR.RING Ø 23.9X28X2, KT16,18,19	3
66	F36204966	INLET VALVE SEAT, KT16,18,19	3
67	F36712101	GR. DELIVERY VALVE, KT16,18,19	3
68	F36714401	GR. INTAKE VALVE, KT16,18,19	3
69	F90387800	O-RING Ø 39.34X2.62 NBR, KT20,22	6
70	F90522000	ANTI-EXTR.RING Ø 40.9X454X1.5, KT20,22	3
71	F71211070	PLUG Ø 45, KT20,22	6
72	F94740100	SPRING Ø 12X17, KT20,22	3
73	F36203966	SPHERICAL VALVE PLATE, KT20,22	6
74	F36204366	OUTLET VALVE SEAT, KT20,22	3
75	F90385100	O-RING Ø 21.89X2.62 90 SH., KT20,22	3
76	F90514500	ANTI-EXTR.RING Ø 22.9X27X1.5, KT20,22	3
77	F70224466	VALVE SPACER, KT20,22	3
78	F90517900	ANTI-EXTR.RING Ø 31,4X35,5X1,5, KT20,22	6
79	F90386600	O-RING Ø 29,82X2,62 90 SH., KT20,22	3
80	F94739700	SPRING Ø 11.4X20, KT20,22	3
81	F90386600	O-RING Ø 29,82X2,62 90 SH., KT20,22	3
82	F90517700	ANTI-EXTR.RING Ø 30X34.5X1.5, KT20,22	3
83	F36204266	INLET VALVE SEAT, KT20,22	3
84	F36713901	OUTLET VALVE, KT20,22	3
85	F36713801	INTAKE VALVE, KT20,22	3
86	F99308400	SCREW, M8X30	6
87	F10067320	FLANGE "A"	1
88	F99313633	SCREW, M8X45	6
89	F10075547	ELASTIC GASKET SEAL	1
90	F10743001	GASKET Ø 30X25.4	1
91	F10075020	FLANGE	1
92	F70020535	CRANKSHAFT	1
93	F97615200	PIN Ø 5x10	1
94	F70223454	DOUBLE PTO	1
95	F96716000	WASHER Ø 12X18X1 DIN 988	1
96	F99429500	SCREW M12X35 UNI5931	1
97		FLUSHING MANIFOLD	1
98	F98206000	PLUG Ø 15	2
99	F70050266	PLUNGER GUIDE ROD	3
100	F99192500	SCREW, M6X35	6
101	F90352800	O-RING, Ø 29X1.5	3
102	F70020935	CRANKSHAFT, Ø 26 HYP SAE-B	1
103	F10085322	MOTOR FLANGE, SAE-B	1
104	F90206500	PLUG Ø 17	1
105	F70226771	RING Ø 30 HYP	1
106	F70227034	SCREW, M6X12	1
107	F92202500	NUT, M6X5	1
108	F36210151	INTERNAL VALVE GUIDE	3
109	F99180900	SCREW, M6X10	1
110	F96693650	WASHER, Ø 6.4X11X0.7 - ATEX	1
	99426600	FEET BOLTS, M12-1.75X22, OPTIONAL	4
	96719500	FEET SERRATED WASHER, M12, OPTIONAL	4

**REPAIR KITS**

KIT NUMBER	<b>F2227 Plunger Packing Kit KT16A &amp; WK525</b>	<b>F2228 Plunger Packing Kit KT18A &amp; WK530</b>	<b>F2408 Plunger Packing Kit KT19A &amp; WK531</b>	<b>F2229 Plunger Packing Kit KT20A</b>	<b>F2230 Plunger Packing Kit KT22A</b>
Positions Included	37, 39, 41, 42,	37, 39, 41, 42,	37, 39, 41, 42	37, 39, 41, 42,	37, 39, 41, 42,

KIT NUMBER	<b>F2031 Inlet Valve Kit KT16A/KT18A/KT19A WK525/WK530/WK531</b>	<b>F2022 Inlet Valve Kit KT20A/KT22A</b>
Positions Included	64, 65, 68, 81, 82, 85	64, 65, 68, 81, 82, 85

KIT NUMBER	<b>F2256 Outlet Valve Kit KT16A/KT18A/KT19A WK525/WK530/WK531</b>	<b>F2023 Outlet Valve Kit KT20A/KT22A</b>
Positions Included	57, 67, 75, 76, 84	57, 67, 75, 76, 84

KIT NUMBER	<b>F2231 Complete Seals Kit KT16A &amp; WK525</b>	<b>F2232 Complete Seals Kit KT18A &amp; WK530</b>	<b>F2409 Complete Seals Kit KT19A &amp; WK531</b>	<b>F2233 Complete Seals Kit KT20A</b>	<b>F2234 Complete Seals Kit KT22A</b>
Positions Included	3, 5, 7, 10, 14, 16, 22, 23, 26, 37, 39, 41, 42, 48, 50, 51, 57, 59, 60, 64, 65, 69, 70, 75, 76 78, 79, 81, 82	3, 5, 7, 10, 14, 16, 22, 23, 26, 37, 39, 41, 42, 48, 50, 51, 57, 59, 60, 64, 65, 69, 70, 75, 76 78, 79, 81, 82	3, 5, 7, 10, 14, 16, 22, 23, 26, 37, 39, 41, 42, 48, 50, 51, 57, 59, 60, 64, 65, 69, 70, 75, 76 78, 79, 81, 82	3, 5, 7, 10, 14, 16, 22, 23, 26, 37, 39, 41, 42, 48, 50, 51, 57, 59, 60, 64, 65, 69, 70, 75, 76 78, 79, 81, 82	3, 5, 7, 10, 14, 16, 22, 23, 26, 37, 39, 41, 42, 48, 50, 51, 57, 59, 60, 64, 65, 69, 70, 75, 76 78, 79, 81, 82

KIT NUMBER	<b>F2156 Connecting Rod Bushing Kit (Standard)</b>	<b>F2157 Connecting Rod Bushing Kit (+0.25)</b>	<b>F2158 Connecting Rod Bushing Kit (+0.50)</b>
Positions Included	31, 32	31, 32	31, 32

**16. EXPLODED VIEW AND PARTS LIST**

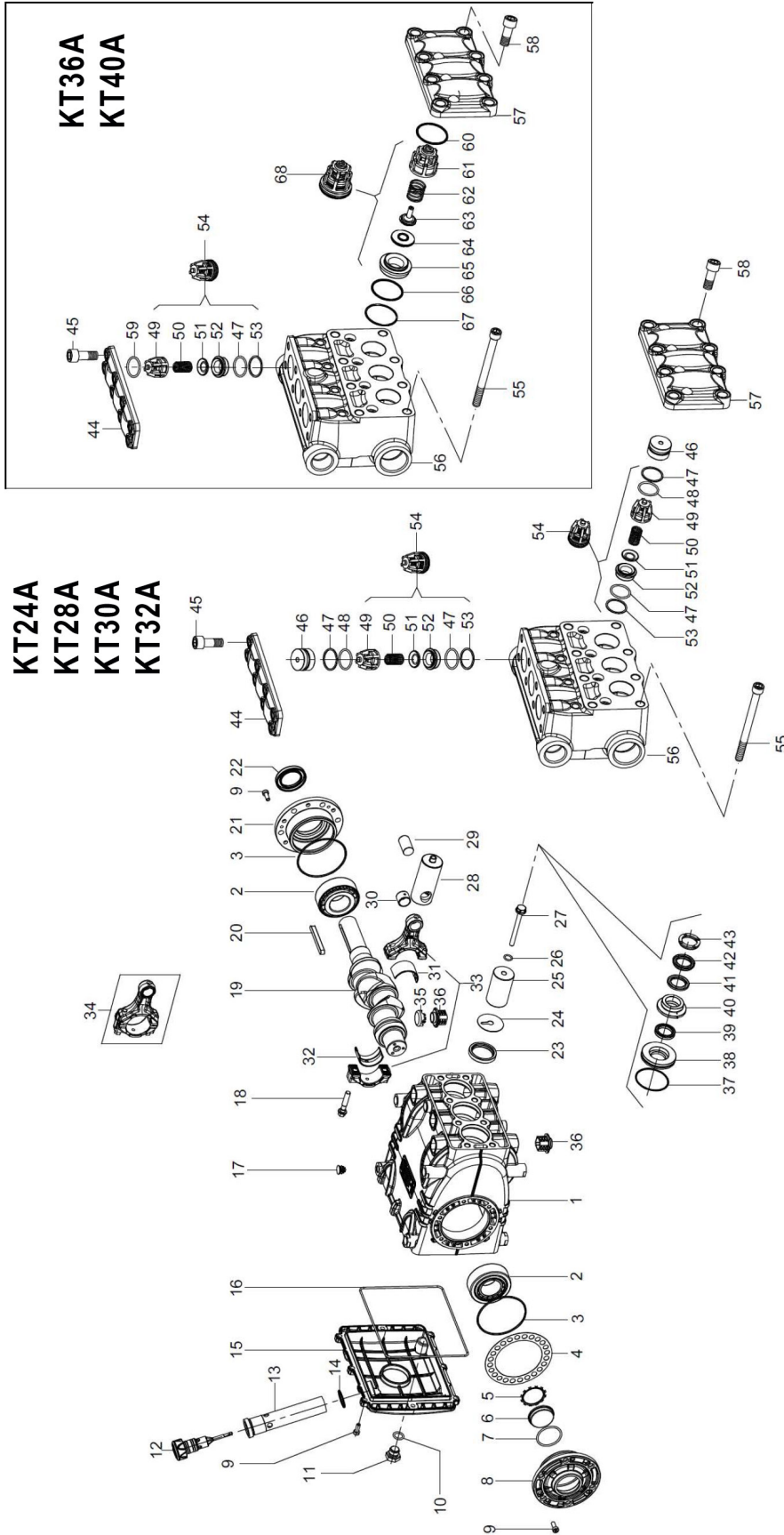

**KT24A  
KT28A  
KT30A  
KT32A**

**KT36A  
KT40A**

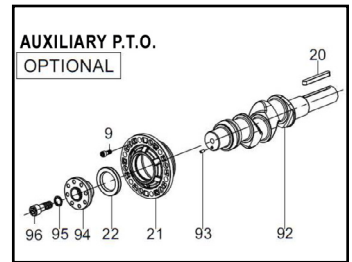
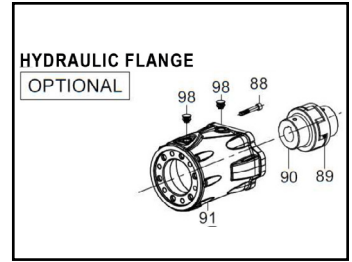
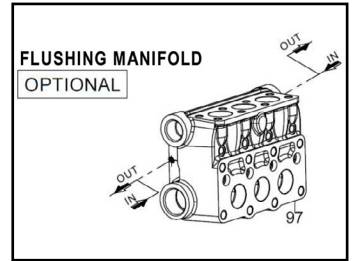

Item	Part #	Description	QTY.
1	70010022	CRANKCASE	1
2	91847700	TAPER ROLLER BEARING	2
3	F90391500	O-RING D. 80.6X2.62	2
4	F70220081	SHIM 0.1 MM	1
	F70220381	SHIM 0.25 MM	
5	90075600	CIRCLIP D.45	1
6	70211801	OIL SIGHT GLASS	1
7	90387700	O-RING 39.34X2.62	1
8	F70150122	BEARING COVER (OIL GLASS SIDE)	1
9	F99185400	SCREW M6X16 UNI 5931	20
10	90383300	O-RING 13.95X2.62	1
11	98210050	PLUG G3/8x13	1
12	98211500	OIL DIPSTICK D.21,5X70	1
13	F72210695	DIP STICK TUBE	1
14	90360400	O-RING 25.12X1.78	1
15	F70160622	CRANKCASE COVER	1
16	F90394200	OR D.190.17X2.62 NBR 70SH	1
17	98200500	PLUG D. 15	5
18	F99312300	CONN.ROD BOLT M8X1X42	6
19	F70020635	CRANKSHAFT	1
20	F91490000	KEY	1
21	F70150022	BEARING COVER (PTO SIDE)	1
22	90166800	OIL SEAL D.35X52X7	1
23	90167700	OIL SEAL D.36X47X7	3
24	F96709900	WASHER D.10X45	3
25	F70040209	PISTON D. 24X62	3
	F70040309	PISTON D. 28X62	
	F70040409	PISTON D. 30X62	
	F70041309	PISTON D. 32X63	
	F70040509	PISTON D.36X63	
	F70041209	PISTON D.40X63	
26	90358400	O-RING D.10,82X1,78(2043)90SH	3
27	F70224136	PISTON BOLT	3
28	F70050015	PISTON GUIDE	3
29	F97742000	GUDGEON PIN D.18X36	3
30	F90910000	CONNECTING ROD BUSHING	3
31	F90922000	UPPER HALF-BUSH (BIG END)	3
	F90922100	UPPER HALF-BUSH (BIG END) +0.25	
	F90922200	UPPER HALF-BUSH (BIG END) +0.50	
32	F90922300	LOWER HALF-BUSH (BIG END)	3
	F90922400	LOWER HALF-BUSH (BIG END) +0.25	
	F90922500	LOWER HALF-BUSH (BIG END) +0.50	
34	F70030501	CONNECTING ROD COMPLETE	3
35	F71225951	PLUG CAP	3
36	F70222551	CRANKCASE PLUG	6
37	F90362600	O-RING D. 50.52X1.78	3
38	F70080270	PACKING RETAINER D. 24	3
	F70080370	PACKING RETAINER D. 28	
	F70080470	PACKING RETAINER D. 30	
	F70082270	PACKING RETAINER D.32	
	F70081270	PACKING RETAINER D.36	
	F70082170	PACKING RETAINER D. 40	
39	F90273700	L.P. SEAL D.24X32X5.5	3
	F90275000	L.P. SEAL D.28X36X5.5	
	F90276000	L.P. SEAL D.30X38X5.5	
	F90278000	L.P. SEAL	
	F90279800	SEAL D.36X44X5.5 L.P.	
	F90282800	SEAL D.40X48X5.5 L.P.	
40	F70216270	INTERMEDIATE RING D.24	3
	F70216370	INTERMEDIATE RING D.28	
	F70216470	INTERMEDIATE RING D.30	
	F70225270	INTERMEDIATE RING D.32	
	F70222470	INTERMEDIATE RING D.36	
	F70224970	INTERMEDIATE RING D.40	
41	F90274300	RESTOP RING D.24X35X5/2.2	3
	F90275500	RESTOP RING D.28X45X8.5/4	
	F90277400	RESTOP RING D. 30	
	F90278400	RESTOP RING D.32X44X5.5/3	
	F90281800	RESTOP RING D.36X48X3/6	
	F90283800	RESTOP RING D.40X55X8/4.5	

Item	Part #	Description	QTY.
42	F90274500	PACKING 24X35X6	3
	F90275800	PACKING D.28X45X8.5/5	
	F90277000	PACKING 30X45X7.5	
	F90278800	PACKING D.32X44	
	F90282000	PACKING 36X48X6	
43	F90283200	PACKING D. 40X55X7.5/4.5	3
	F70100251	HEAD RING D. 24	
	F70100351	HEAD RING D. 28	
	F70100451	HEAD RING D. 30	
	F72100051	HEAD RING D.32	
	F71100251	HEAD RING D.36	
44	F71100351	HEAD RING D.40	3
	F70225115	VALVE COVER	
45	F99429500	SCREW M12X35 UNI5931 12.31	8
46	F70225370	VALVE PLUG	6
47	90386500	O-RING 29,82X2.62	12
48	F90518000	ANTI-EXTR.RING D.32.4X36.5X1.5	6
49	F36204751	VALVE CAGE	3
50	F94745000	SPRING D. 16X27,5	3
51	F36211766	SPHERICAL VALVE KT24A, 28A, 30A, 33A	3
	F36201076	SPHERICAL VALVE KT36A, 40A	
52	F36204866	VALVE SEAT	3
53	F90517800	ANTI-EXTR.RING D.31X35.5X1.5	3
54	F36720801	GR. INTAKE VALVE	3
55	99381600	SCREW M10X110 UNI5931 8.8	8
56	F70126715	MANIFOLD FOR PIST. D. 24 NPT	1
	F70126815	MANIFOLD FOR PIST. D. 28-30 NPT	
	F70126915	MANIFOLD FOR PIST. D. 32 NPT	
	F70127015	MANIFOLD FOR PIST. D. 36 NPT	
	F70127115	MANIFOLD FOR PIST. D. 40 NPT	
57	F70225015	INLET VALVE COVER	1
58	F99485000	SCREW M14X40 UNI5931 12.9	8
59	F90388550	O-RING D.45.69x2.62 NBR 90 SH.	3
60	F90389400	O-RING D.53.65x2.62 NBR 90 SH	3
61	F36204505	VALVE CAGE SS	3
62	F94754000	SPRING D.24.7X27	3
63	F36208651	INNER VALVE GUIDE	3
64	F36208502	SPHERICAL VALVE COMPLETE	3
65	F36211666	INLET VALVE SEAT	3
66	F90388000	O-RING D.42.52X2.62	3
67	F90523300	ANTI-EXTR.RING D43.5x48x1.5	3
68	F36720701	INTAKE VALVE	3
97	99426600	FEET BOLTS, M12-1.75X22, OPTIONAL	4
	96719500	FEET SERRATED WASHER, M12, OPTIONAL	4
<b>OPTIONAL FLUSHING MANIFOLD</b>			
97		FLUSHING MANIFOLD	1
<b>OPTIONAL HYDRAULIC FLANGE</b>			
88	99313600	SCREW, M8X45	6
89	F10075547	ELASTIC GASKET SEAL	1
90	F10743001	GASKET Ø 30X25.4	1
91	F10075220	FLANGE	1
98	98206000	PLUG D. 15 - T18	2
<b>OPTIONAL AUXILIARY P.T.O.</b>			
9	F99185400	SCREW M6X16 UNI 5931	6
20	91490000	KEY	1
21	F70150022	BEARING COVER (PTO SIDE)	1
22	90166800	OIL SEAL D.35X52X7	1
92	F70020735	CRANKSHAFT	1
93	F97615200	PIN D.5x10	1
94	F70223454	DOUBLE PTO	1
95	F96716000	WASHER D.12X18X1 DIN 988	1



**REPAIR KITS**

KIT NUMBER	F2006 Plunger Packing Kit KT24A	F2008 Plunger Packing Kit KT28A	F2019 Plunger Packing Kit KT30A	F2248 Plunger Packing Kit KT32A	F2133 Plunger Packing Kit KT36A	F2249 Plunger Packing Kit KT40A
Positions Included	37, 39, 41, 42	37, 39, 41, 42	37, 39, 41, 42	37, 39, 41, 42	37, 39, 41, 42	37, 39, 41, 42

KIT NUMBER	F2246* Inlet Valve Kit KT24A/28A 30A/32A	F2247 Inlet Valve Kit KT36A/40A	F2246 Outlet Valve Kit	F2259 Outlet Valve Kit KT36A/40A
Positions Included	47, 53, 54, 68	47, 53, 54, 68	47, 54	47, 54,

**\*F2246 Includes 6 valve assemblies**

KIT NUMBER	F2250 Complete Seals Kit KT24A	F2251 Complete Seals Kit KT28A	F2252 Complete Seals Kit KT30A	F2253 Complete Seals Kit KT32A	F2254 Complete Seals Kit KT36A	F2255 Complete Seals Kit KT40A
Positions Included	3, 5, 7, 10, 14, 16, 22, 23, 26, 37, 39, 41, 42, 47, 48, 53, 59, 60, 66, 67	3, 5, 7, 10, 14, 16, 22, 23, 26, 37, 39, 41, 42, 47, 48, 53, 59, 60, 66, 67	3, 5, 7, 10, 14, 16, 22, 23, 26, 37, 39, 41, 42, 47, 48, 53, 59, 60, 66, 67	3, 5, 7, 10, 14, 16, 22, 23, 26, 37, 39, 41, 42, 47, 48, 53, 59, 60, 66, 67	3, 5, 7, 10, 14, 16, 22, 23, 26, 37, 39, 41, 42, 47, 48, 53, 59, 60, 66, 67	3, 5, 7, 10, 14, 16, 22, 23, 26, 37, 39, 41, 42, 47, 48, 53, 59, 60, 66, 67

KIT NUMBER	F2156 Connecting Rod Bushing Kit (Standard)	F2157 Connecting Rod Bushing Kit (+0.25)	F2158 Connecting Rod Bushing Kit (+0.50)
Positions Included	31, 32	31, 32	31, 32

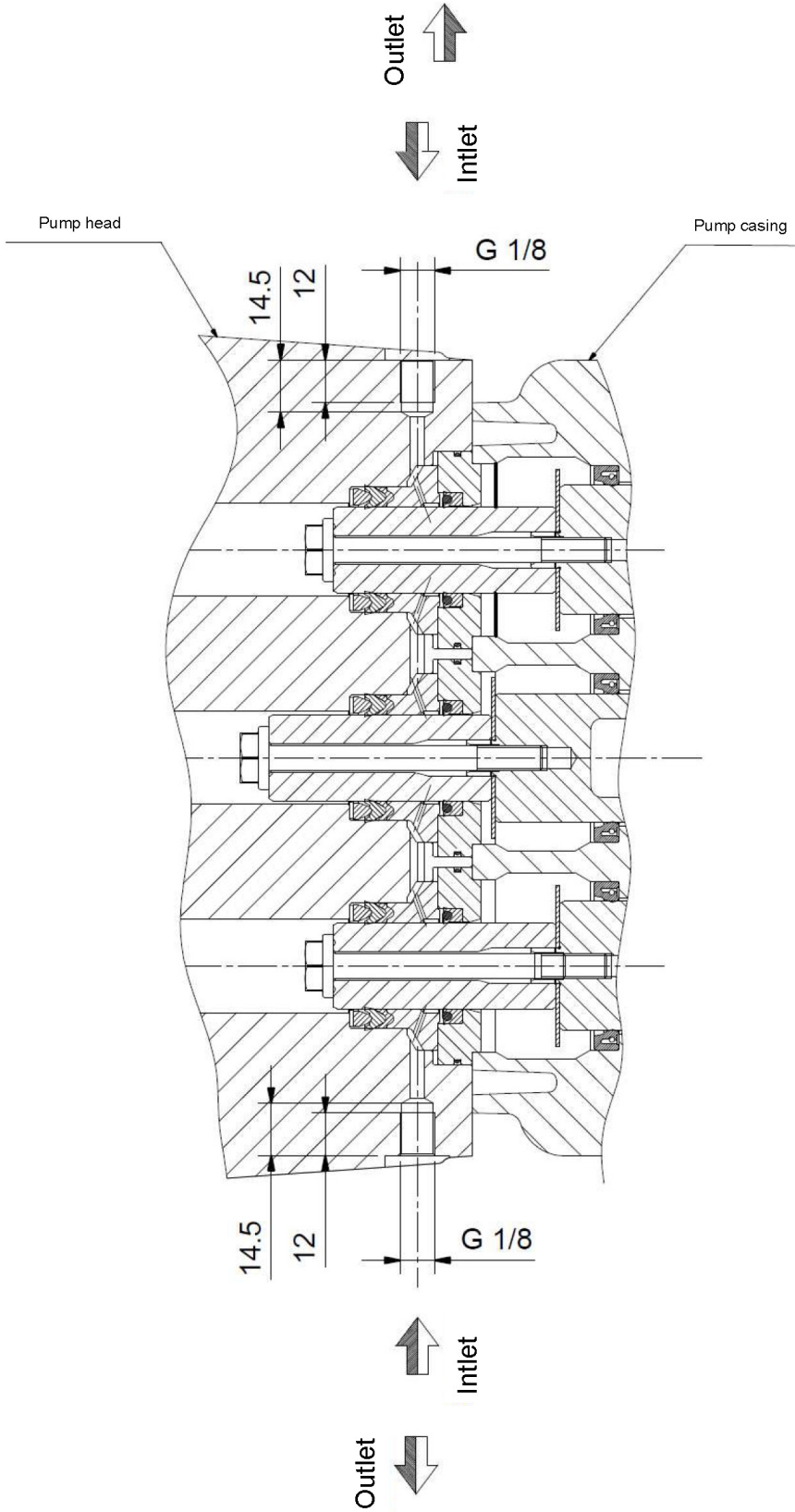

## 18. MAINTENANCE LOG

### HOURS & DATE

<b>OIL CHANGE</b>							
<b>GREASE</b>							
<b>PACKING REPLACEMENT</b>							
<b>PLUNGER REPLACEMENT</b>							
<b>VALVE REPLACEMENT</b>							



GP Companies, Inc.  
1174 Northland Drive  
Mendota Heights, MN 55120  
Phone:651.686.2199 Fax: 800.535.1745  
www.generalpump.com email: sales@gpcompanies.com

Ref 300941 Rev. B  
02-24