

# KT16A/18A/20A/22A Series

## FEATURES

- High pressure, Triplex Plunger Pump, available in 4 flows
- Double pressure packings
- Pressure packing integrated cooling system
- Horizontally fitted in-line valves
- Splash lubrication
- SAE "B" hydraulic drive available

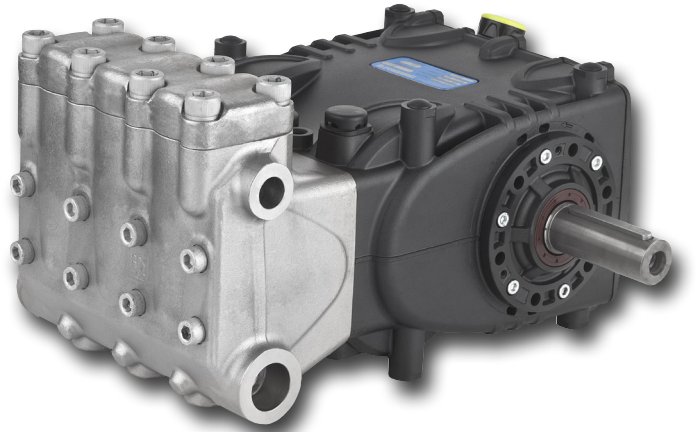

## MATERIALS

- High resistance light alloy crankcase
- Stainless steel manifold
- Tapered roller rim bearings
- Special anti-friction light alloy connecting rods
- Forged alloy steel crankshaft, hardened, tempered and nitrided
- Cast iron plunger guide, nickel treated
- Solid ceramic plungers
- Stainless steel valves

Product Group: V

## COMMON SPECIFICATIONS

- Maximum Inlet Pressure: . . . . . 45 PSI
- Minimum Inlet Pressure: . . . . . PSI
- Maximum Fluid Temperature: . . . . . \*140° F
- Inlet Port Thread: . . . . . 1" NPT-F
- Discharge Port Thread: . . . . . 1/2" NPT-F
- Shaft Diameter: . . . . . 1.181" / 30 mm
- Stroke: . . . . . 1.102"/26 mm
- Pump Dimensions: . . . . . 15.55"L x 13.4"W x 8.35"H
- Crankcase Oil Capacity: . . . . . 67.6 oz. (2 liters)  
 . . . . . (use GP Series 220 Oil)
- Shipping Weight: . . . . . 100 lbs./40kg

\*Please consult technical guide or GP Sales Representative for Temperature/Inlet Pressure Information.

MODEL	GPM/LPM	PSI/BAR	RPM	BORE	HP
KT16A	7.1 GPM/27 LPM	7250 PSI/500 BAR	1750 RPM	.629 in./16 mm	35
KT18A	9.2 GPM/35 LPM	5800 PSI/400 BAR	1750 RPM	.708 in./18 mm	36
KT20A	11.4 GPM/43 LPM	4650 PSI/320 BAR	1750 RPM	.787 in./20 mm	36
KT22A	13.7 GPM/52 LPM	3630 PSI/250 BAR	1750 RPM	.866 in./22 mm	34

Volumes are theoretical at 100% volumetric efficiency.



General Pump  
 is a member of  
 The Interpump Group



Ref 300914 Rev C  
 09-18



# KT16A/18A/20A/22A series

## Technical Details

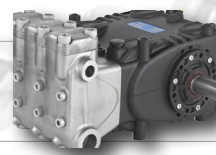

### DRIVE OPTIONS

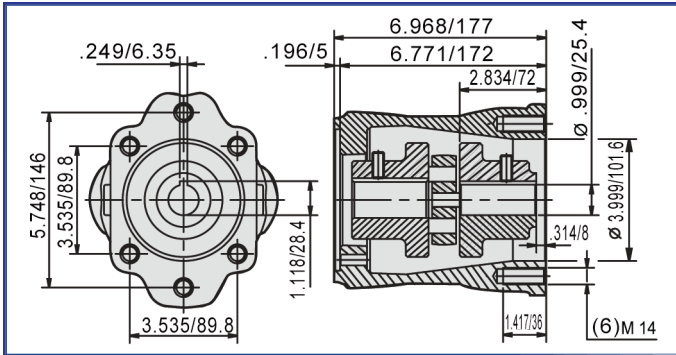

**SAE-J 744-B hydraulic bell housing and flexible coupler.**



**SAE J744-B Spline Shaft  
13T 16/32 DP Hydraulic Drive.**

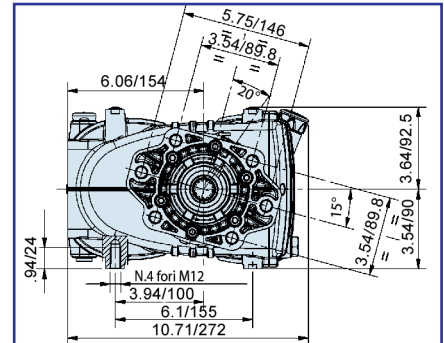
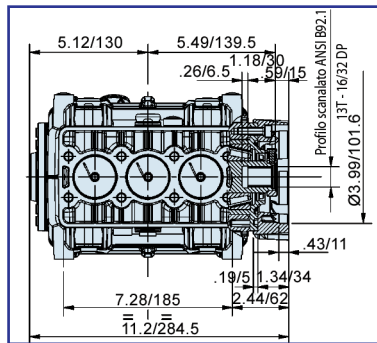

**ZRPM1 RPM Counter**  
Inductive proximity sensor, c/w female connector M12 4 pin, IP67, field attachable, ring nut reduction M18 x 1.  
Power Supply: 12/24 VDC

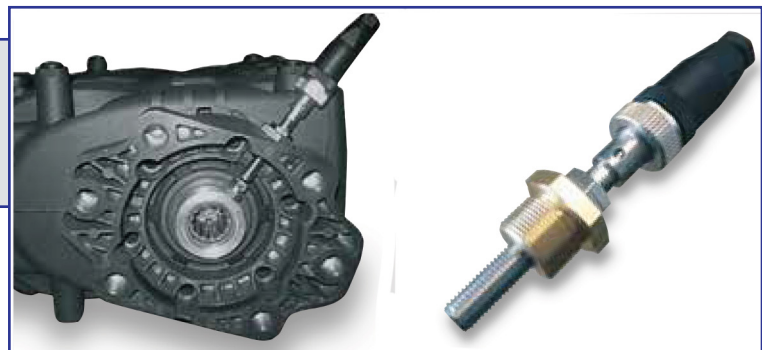

# KT16A/18A/20A/22A series

## Technical Details



### OVERALL DIMENSIONS

