

Owner's Manual

- *Installation*
- *Use*
- *Maintenance*

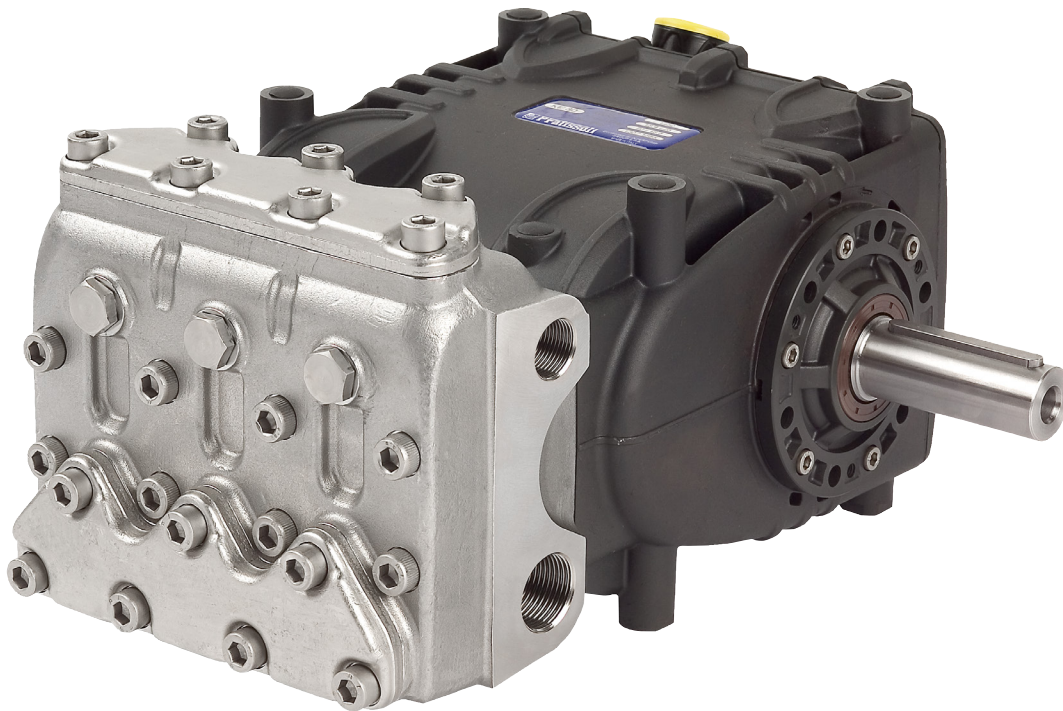

INDEX

1.	INTRODUCTION	Page 4
2.	SYMBOL DESCRIPTIONS	Page 4
3.	SAFETY	Page 4
	3.1 General safety instructions	Page 4
	3.2 High pressure system safety requirements	Page 4
	3.3 Safety of operation	Page 5
	3.4 General procedures using nozzles	Page 5
	3.5 Safety of maintenance	Page 5
4.	PUMP IDENTIFICATION	Page 5
5.	TECHNICAL FEATURES	Page 6
6.	DIMENSIONS AND WEIGHT	Page 6
7.	GENERAL INFORMATION ABOUT SPECIFIC PUMP USE	Page 7
	7.1 Water temperature	Page 7
	7.2 Maximum flow and pressure ratings	Page 7
	7.3 Lowest operating RPM	Page 7
	7.4 Recommended lubricant types and Manufacturers	Page 7
8.	PORTS AND CONNECTIONS	Page 8
9.	PUMP INSTALLATION	Page 8
	9.1 Installation	Page 8
	9.2 Direction of rotation	Page 8
	9.3 Version change	Page 8
	9.4 Hydraulic connections	Page 9
	9.5 Pump feeding	Page 9
	9.6 Suction line	Page 9
	9.7 Filtering	Page 9
	9.8 Delivery line	Page 10
	9.9 Internal diameter of hose	Page 10
	9.10 V-belt transmission	Page 11
	9.11 Transmission definition	Page 11
	9.12 Definition of belt static tension values	Page 12
10.	START UP AND OPERATION	Page 12
	10.1 Preliminary inspections	Page 12
	10.2 Starting up	Page 13
11.	PREVENTATIVE MAINTENANCE	Page 13
12.	STOPPING THE PUMP FOR LONG PERIODS	Page 13
	12.1 Inactivity for long periods	Page 13
	12.2 After Use	Page 13

INDEX (continued)

13. **PRECAUTIONS AGAINST FREEZING** Page 13

14. **WARRANTY TERMS** Page 13

15. **TROUBLESHOOTING** Page 13

16. **EXPLODED VIEWS AND PARTS** Page 15

17. **MAINTENANCE LOG** Page 17

1. INTRODUCTION

This manual describes the use and maintenance instructions of the KEZ pump, and should be carefully read and understood before using the pump.

Correct use and adequate maintenance will guarantee the pumps trouble-free operation for a long time. General Pump declines any responsibility for damage caused by misuse or the non-observance of the instructions indicated in this manual.

Upon receiving the pump, check that it is complete and in perfect condition.. Should anything be found out of order, please contact us before installing and starting the pump.

2. SYMBOL DESCRIPTIONS

**Warning**

Potential Danger

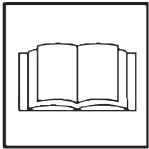

Read carefully and understand the manual before operating the pump

**Danger**

High Voltage

**Danger**

Wear protective mask

**Danger**

Wear goggles

**Danger**

Wear protective gloves

**Danger**

Wear protective boots

3. SAFETY

3.1 General Safety Indications

The misuse of pumps and high pressure units may cause severe injury to people and/or damage to property. Anyone requested to assemble or use high pressure units must possess the necessary competence to do so, should be aware of the characteristics of the components assembled/used, and must adopt all the necessary precautions in order to guarantee maximum safety in any operating condition. In the interest of safety, no precaution that is reasonably feasible must be neglected, both by the Manufacturer and the Operator.

3.2 High pressure unit safety requirements

1. The pressure line must always be equipped with a safety valve.
2. High pressure unit components, in particular for those units working outside, must be adequately protected against rain, frost and heat.
3. The units electrical parts must be adequately protected from water spray, and must comply with the specific norms in force.
4. High pressure hoses must be correctly sized for the units maximum operating pressure, and must only be used within the pressure range indicated by the hose manufacturer.
5. The extremities of high pressure hoses must be sheathed and fastened to a steady structure in order to avoid dangerous whiplashes should they burst or should their connections break.
6. Appropriate safety guards must be provided for the pump transmission systems (joints, pulleys and belts, auxiliary drives).

3.3 Safety During Operation

The working area of a high pressure system must be clearly signaled. Access must be prohibited to non-authorized personnel and, if possible, the area must be fenced in. The personnel authorized to access this area must be previously trained, and informed about the risks that may arise from failures or malfunctions of the high pressure unit.

Before starting the unit, the operator must check:

1. That the high pressure unit is correctly fed (see paragraph 9.5).



3.3 Safety of Operation (continued)

2. That pump intake filters are perfectly clean; we advise to use a device that indicates the filters clogging level.
3. That electrical parts are adequately protected and in perfect conditions.
4. That high pressure hoses do not show apparent signs of abrasion, and that fittings are in perfect shape.

Any anomaly or reasonable doubt that may arise before or during operation must be promptly reported and verified by competent personnel. In these cases, pressure must be immediately released and the high pressure unit stopped.



3.4 General Procedures For Using Nozzles

1. The Operator must always place his own and other worker's safety before any other interest; his actions should always be governed by good sense and responsibility.
2. The Operator must always wear a helmet with a protective visor, waterproof clothing, and appropriate boots capable of guaranteeing grip on wet pavement.

Note: appropriate clothing will effectively protect against water spray, but it may not offer adequate protection against the direct impact of water jets or sprays from a close distance. Some circumstances may require further protection.

3. We advise to employ a team of at least two Operators, able to provide mutual and immediate assistance if needed, and to rotate their duties in case of long and heavy work.
4. Access to the work area that is within the water jets' range must be absolutely forbidden; the area must be free of objects that may be unintentionally hit by the pressurized jet, causing damage or dangerous situations.
5. The water jet must only and always be directed towards the work area, even during testing or preliminary inspections.
6. The Operator must always pay attention to the trajectory of the debris removed by the water jet. If necessary, adequate side guards must be provided by the Operator in order to protect anything that may be accidentally exposed.
7. For no reason must the Operator be distracted during operation. The personnel that needs to access the working area must wait for the Operator to suspend his work, and then immediately make his presence known.
8. For safety reasons, it is important that each member of the team is perfectly aware of the intentions and actions of other team members in order to avoid dangerous misunderstandings.

9. The high pressure unit must not be started and brought up to pressure unless each member of the team is in his designated position, and the Operator has already directed the nozzle towards the work area.

3.5 Safety During Unit Maintenance

1. The maintenance of the high pressure unit must be done within the time intervals indicated by the Manufacturer, who is responsible for the entire unit's compliance with the norms in force.
2. Maintenance must always be carried out by specialized and authorized personnel.
3. Assembly and disassembly of the pump and its various components must be performed exclusively by authorized personnel, using appropriate tools in order to avoid damage to components and connections.
4. To guarantee total reliability and safety, always use original spare parts.

4. PUMP IDENTIFICATION

Each pump (fig. 1) has: its own serial number XX.XXX.XXX (see point 1) and a rating plate (see point 2) that indicates:

- Pump model and version
- Maximum RPM
- Power absorbed Hp-kW
- Flow Rate l/mn - GPM
- Pressure bar/PSI

Pump model, version and serial number must always be specified when ordering spare parts.

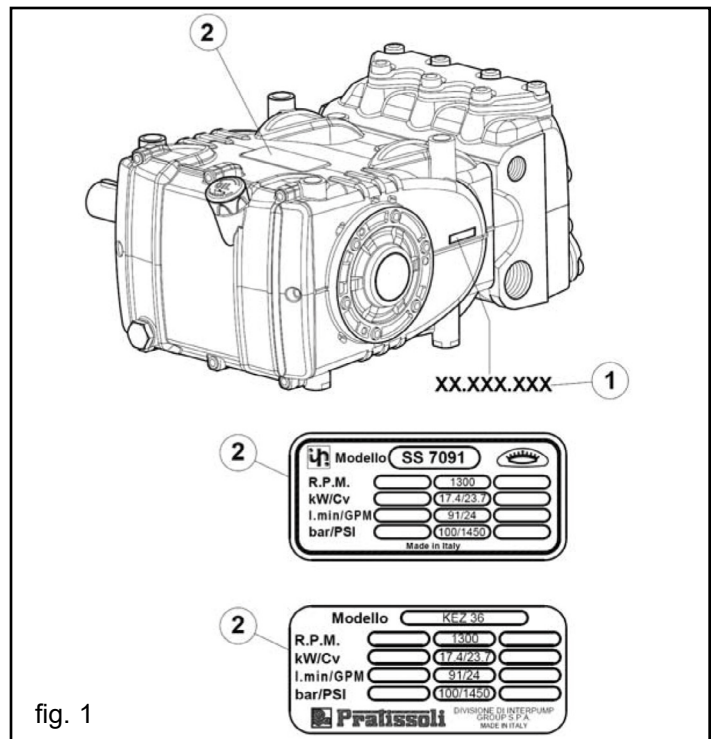

fig. 1

5. TECHNICAL FEATURES

MODEL	RPM	FLOW RATE		PRESSURE		POWER	
		GPM	l/min	PSI	Bar	Hp	kW
KEZ20A	1450 RPM	8.0	30	3,000	200	16.0	11.7
KEZ22A	1450 RPM	10.0	37	3,000	200	19.0	13.9
KEZ24A	1450 RPM	11.9	45	3,000	200	24.0	17.6
KEZ28HA	1450 RPM	16.1	61	2,170	150	24.0	17.6
KEZ30HA	1450 RPM	18.5	70	1,880	130	24.0	17.6
KEZ36HA	1450 RPM	26.4	100	1,450	100	26.0	19.1

6. DIMENSIONS AND WEIGHT

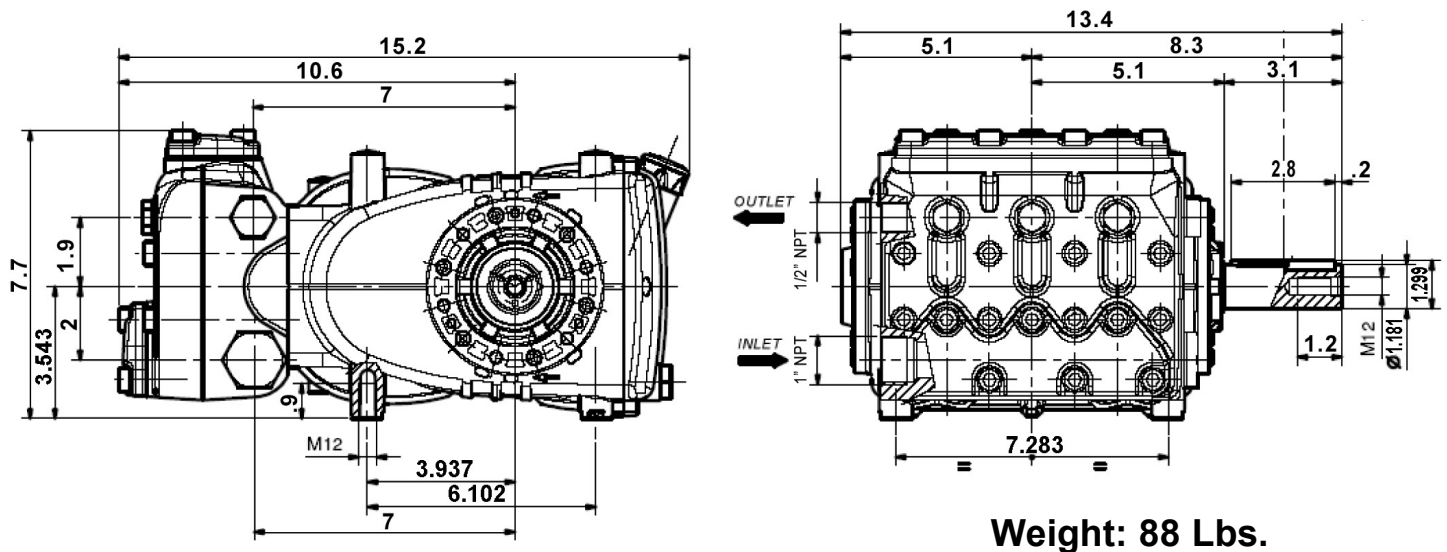

fig. 2

7. INFORMATION ABOUT PUMP USE



The KEZ pump has been designed to operate with filtered water (see paragraph 9.7) and at maximum temperature of 185° F.

Other fluids may be used only upon the approval of The Customer Service Department.

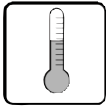

7.1 Water Temperature

The max water temperature is 185°F (85°C)

7.2 Max Flow Rate and Pressure Values

The performance values indicated in the catalog refer to the maximum performance of the pump. Regardless of the power used, pressure and maximum RPM values indicated on the plate may not be exceeded unless expressly authorized by the **Customer Service Department**.

7.3 Lowest RPM

Any RPM value different from what is indicated in the performance table (see chapter 5) must be expressly authorized by the **Customer Service Department**.

7.4 Recommended Lubricant Oil Types & Manufacturers

The pump is delivered with lubricant oil compliant with room temperatures ranging between 0° and 30°C (32° and 89.6° F). Some recommended lubricant types are indicated in the table below; these lubricants are treated additives in order to increase corrosion protection and resistance to fatigue. As an alternative, Automotive SAE 85W-90 gearing lubricants may also be used.

BRAND	TYPE
GENERAL PUMP	SERIES 220
ARAL	Aral Degol BG220
BP	ENERGOL HLP 220
CASTROL	Hyspin VG 220, Magna 220
ELF	POLYTELIS 220
ESSO	NUTO 220
FINA	Cirkan 220
FUCHS	RENOLIN 220
MOBIL	DTE OIL BB
SHELL	TELLUS C 220
TEXACO	RANDO HD 220
TOTAL	CORTIS 220

Check the oil level by using the oil level dipstick (1), fig. 3. Refill if needed. Correct oil level inspection is done with the pump at room temperature; oil is changed with the pump at working temperature, by removing the oil drain plug (2), fig 3 and the oil level dipstick (1), fig. 3.

Oil inspection and changing is to be carried out as indicated in the table in fig. 14, Chapter 11. The amount required is 67.6 oz. (2 liters).

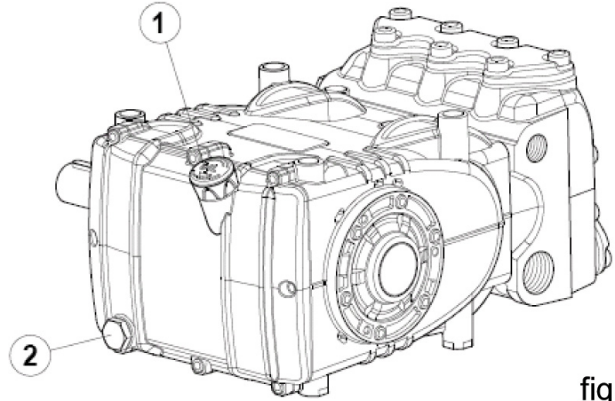

fig. 3



In any case, oil must be changed at least once a year since it may deteriorate by oxidation.

For room temperatures that differ from that mentioned earlier, follow the indications contained in the diagram below, keeping in mind that the oil must have a minimum viscosity of 180 cSt.

VISCOSITY/ROOM TEMPERATURE DIAGRAM

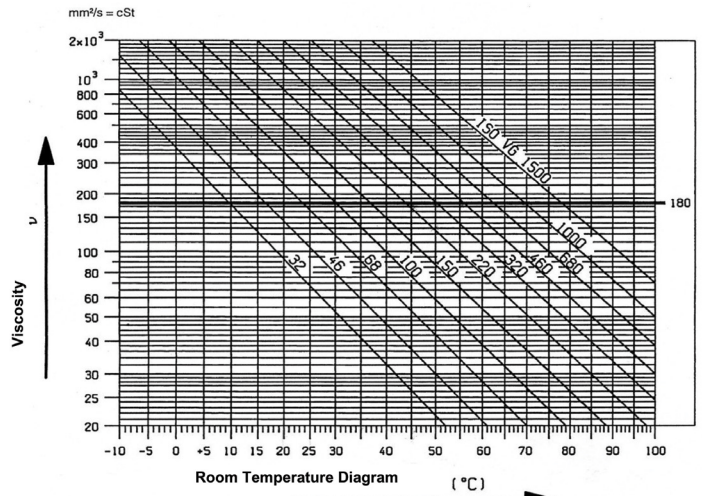

Exhausted oil must be collected in an appropriate recipient and disposed of in appropriate locations. In absolutely no case may it be dispersed into the environment.

8. PORTS AND CONNECTIONS

KEZ Series pumps (see fig. 4) are provided with:

1. 2 inlet ports "IN", 1" NPT. The line can be connected to either of the two inlet ports; the ones not being used must be sealed.
2. 2 outlet ports "OUT", Ø 1/2" NPT
3. 3 auxiliary ports, 1/4" NPT; used for the pressure gauge only.

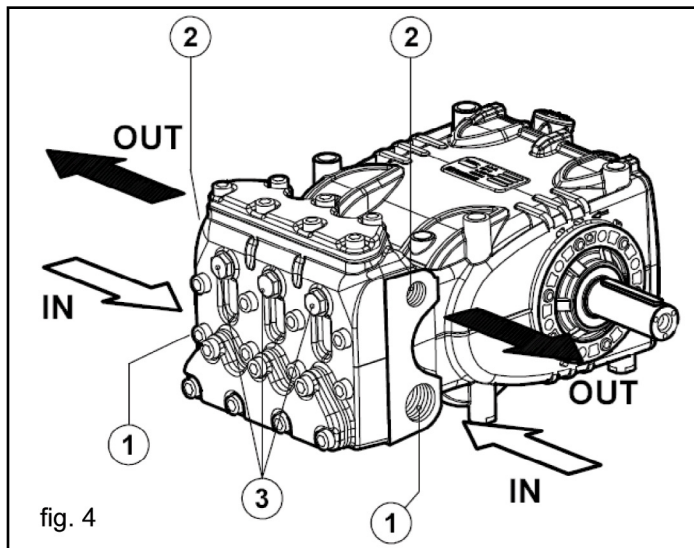

9. PUMP INSTALLATION

9.1 Installation

The pump must be installed in a horizontal position using the correct threaded feet M12; fasten the screws with a torque value of 59 ft. lbs (80 Nm). The base must be perfectly flat and sufficiently rigid in order to avoid bending and misalignments on the pump/transmission coupling axis due to the torque applied during operation. The unit must not be rigidly fixed to the pavement, but requires the use of anti-vibration elements. For special applications, please contact the Customer Service Department.

 **Replace the oil cap (red), located on the rear crankcase cover with the oil dipstick and check oil level.** The oil dipstick must always be accessible, even when the unit is assembled.

 **The pump's shaft (PTO) must not be rigidly connected to the motor unit.** The following transmission types are suggested:

- hydraulic by means of flange; for correct application, please contact the Customer Service Department
- V-belt
- Cardan Joint (please respect the maximum working angles indicated by the manufacturer)
- Flexible joint

9.2 Direction of rotation

An arrow situated on the crankcase near the shaft indicates the correct direction of rotation. Standing in front of the pump head, the direction of rotation must be as shown in fig. 5.

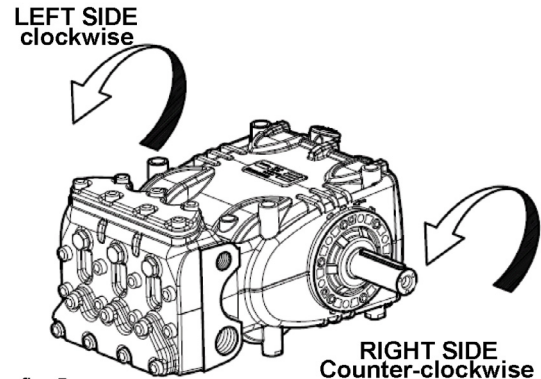

9.3 Version Change

A right version pump is defined when: observing the pump from the head side, the PTO shank is on the right side.

A left version pump is defined when: observing the pump from the head side, the PTO shank is on the left side.

NOTE: Fig. 5 shows a right version.

 **The version may be changed only by specialized and authorized personnel by carefully following the instructions that follow:**

1. Separate the hydraulic part from the mechanical part as indicated in Chapter 2, paragraph 2.2.1 of the repair manual.
2. Rotate the mechanical part by 180°, and reposition the rear crankcase cover so that the oil dipstick is facing upwards; reposition the lifting bracket and the related closing caps in the upper part of the crankcase; finally, correctly reposition the identification plate in its appropriate seat on the crankcase. **Be sure that the lower draining holes on the crankcase near the plungers are open, and not closed by the plastic caps as required for the previous version.**
3. Join the hydraulic part with the mechanical part as indicated in Chapter 2, paragraph 2.2.5 of the repair manual.



9.4 Hydraulic Connections

In order to isolate the system from the vibrations produced by the pump, we advise to build the first section of the duct near the pump (both for intake and delivery) with flexible hose. The consistency of the intake section must allow to avoid deformation caused by the depressurization produced by the pump.

9.5 Pump Feeding

To obtain the best volumetric efficiency, a minimum positive head of 0.20 meters (7.87 inches) is required. In case of fluid temperatures ranging from 95° to 185° F (35° to 85° C) the correct inlet pressures are specified in the graph below.

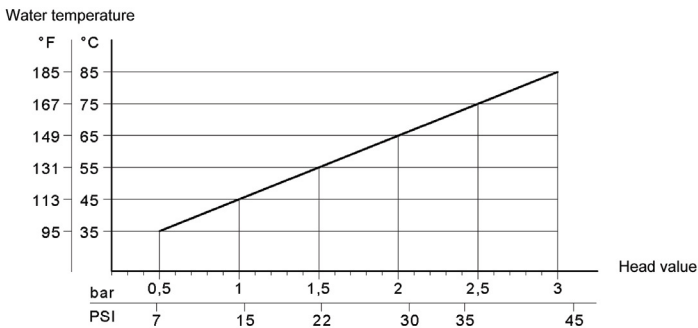

For negative head values, please contact the Customer Service Department.

9.6 Suction Line

For the pump's correct operation, the suction line must have the following characteristics:

1. Minimum internal diameter as indicated in the diagram in paragraph 9.9, and in any case equal or greater than the pump head's value.



Along the duct, avoid localized diameter reductions that may cause pressure drops with subsequent cavitation. Absolutely avoid 90° elbows, connections with other hoses, bottlenecks, counter-slopes, upside down "U" shaped curves, "T" connections.

2. The selected lay-out must allow to avoid cavitation.
3. It should be perfectly airtight, and built in a way that guarantees perfect sealing over time.
4. Avoid pump emptying when stopping (even partial emptying).
5. Do not use hydraulic-type fittings, 3 or 4 way fittings, adapters, etc. , since they may hinder the pump's performance.
6. Do not install Venturi tubes or injectors for detergent intake.
7. Avoid the use of standing valves, check valves, or any other type of one-way valves.
8. Do not connect the by-pass line from the valve directly to the pump suction line.

9. Provide appropriate baffle plates inside the tank in order to avoid water that flows coming from both the by-pass and feeding lines may create turbulence in the tanks outlet port.
10. Make sure that the suction line is perfectly clean inside before connecting it to the pump.

9.7 Filtering

On the suction line, install 1 filter arranged as shown in fig. 6 and fig. 6/a.

With the manual adjustment valve:

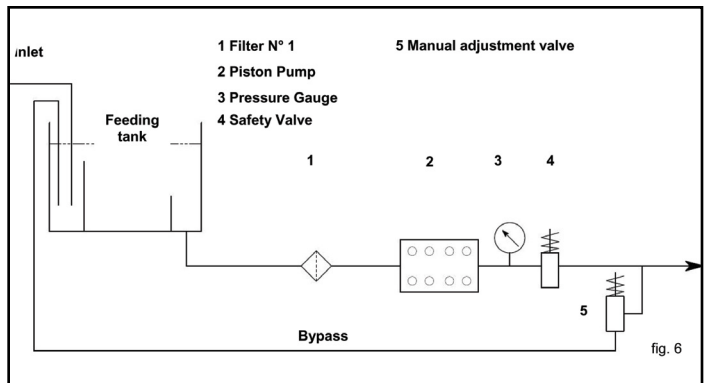

With the pneumatic adjustment valve:

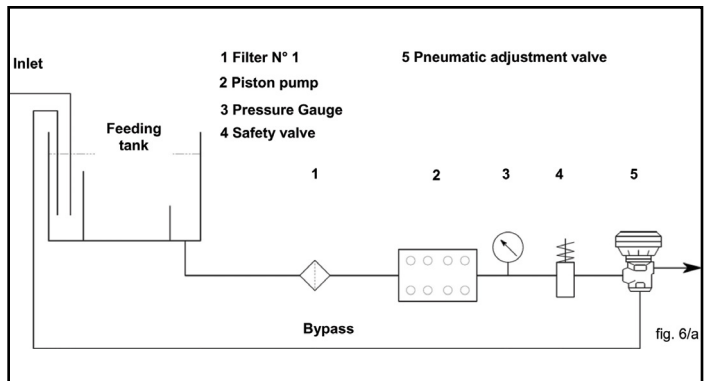

The filter must be installed as close as possible to the pump, should allow easy inspection and have the following characteristics:

1. Minimum capacity 3 times greater than the pump's rated flow value.
2. Filter port diameters must not be smaller than the pump inlet ports.
3. Filtration degree ranging between 200 and 360 µm.



In order to guarantee correct pump operation, it is important to plan periodical cleaning of the filter depending on actual pump usage, water quality and real clogging conditions.

9.8 Delivery Line

To obtain a correct delivery line, please comply with the following installation instructions:

1. The internal diameter of the pump must allow to guarantee correct fluid speed; see diagram in paragraph 9.9
2. The first section of the hose connected to the pump must be flexible in order to isolate pump vibrations from the rest of the system.
3. Use high pressure hoses and fittings that guarantee wide safety margins in any working condition.
4. Install a safety valve on the delivery line.
5. Use pressure switches suitable for the pulsating loads typical of plunger pumps.
6. In the design phase, take into proper account the pressure drop along the line, since this causes a reduction in usage pressure with respect to the value measured at the pump.
7. If the pump pulsations are harmful for particular applications, install an appropriately sized pulsation dampener on the delivery line.

9.9 Internal Diameter of the Hose Line

To determine the internal diameter of the hose, please refer to the following diagram.

Suction Hose

With a flow rate of ~24 GPM (91 l/mn) and water speed of 0.5 m/sec. the diagram line that connects the two scales intersects the central scale, indicating the diameters, at a value of ~ 62 mm (2.4 inch).

Delivery Hose

With a flow rate of ~24 GPM (91 l/mn) and water speed of 5 m/sec. The diagram line that connects the two scales intersects the central scale, indicating the diameters at a value of ~ 19.5 mm (.77 inch).

Optimum speed values:

- Suction: ≤ 0.5 m/sec.
- Delivery: ≤ 5 m/sec.

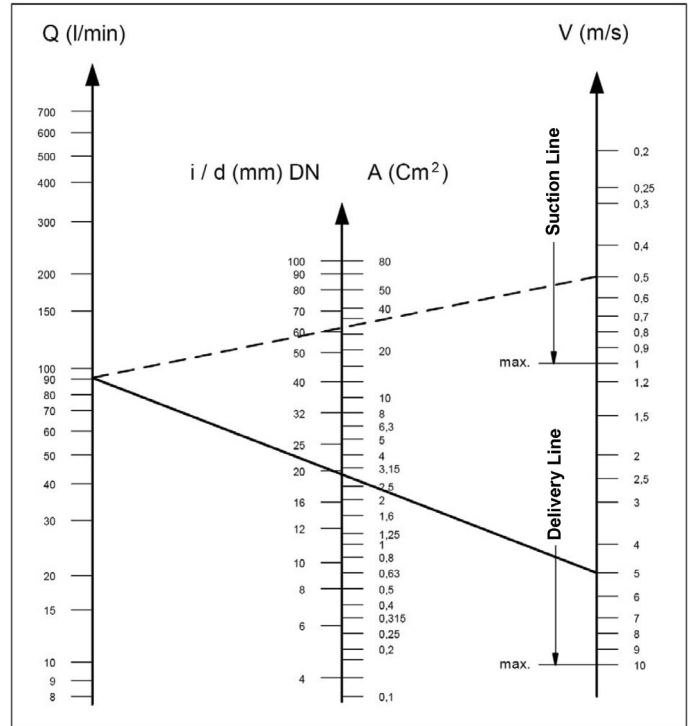

The diagram does not take into consideration the pipe and valve resistance, drop in pressure, due to the pipe length, the viscosity of the pumped fluid, its temperature, etc.

9.10 V-belt Transmission

The pump may be driven by a v-belt system. For this pump model, we suggest to use 2 XPB belts (16.5 x 13 cogged); only for long durations, use the XPC profile; both the characteristics and the power transmission capacity of each belt can be verified on the diagram in fig. 7, in function of the number of rotations normally declared by the Manufacturer. Minimum diameter of the driven pulley (on the pump shaft): ≥ 160 mm. The radial load on the shaft must not be greater than 3000 N (value required for the definition of the lay-out). The transmission is considered adequate if this load is applied at a maximum distance of 30 mm from the shaft shoulder (PTO) as indicated in fig. 10.



For sizing that differs from that indicated above, please, contact our **Customer Service Department**.

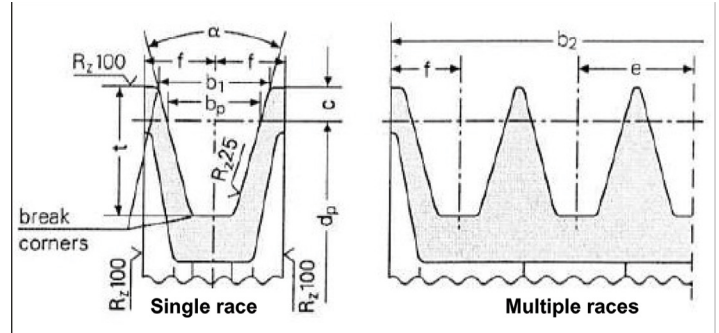

fig. 8

Dimensions (in mm)

Belt section as indicated in DIN 7753 part 1 and B.S. 3790		symbol DIN symbol B.S./ISO	XPB/SPB SPB	XPC/SPC SPC	
Belt section as indicated in DIN 2215 and B.S. 3790		symbol DIN symbol B.S./ISO	17 B	22 C	
Pitch width		b_w	14.0	19.0	
Increased race width $b_1 =$		$\alpha = 34^\circ$	18.9	26.3	
		$\alpha = 38^\circ$	19.5	27.3	
		c	8.0	12.0	
Distance between races		e	23 ± 0.4	31 ± 0.5	
		f	14.5 ± 0.8	20.0 ± 1.0	
Increased race depth		t_{min}	22.5	31.5	
α	34°	For a primitive diameter narrow section v-belt DIN 7753 part 1	d_w	from 140 to 190	from 224 to 315
	38°			> 190	> 315
α	34°	For a primitive diameter classical section v-belt DIN 2215	d_w	from 112 to 190	from 180 to 315
	38°			> 190	> 315
Tolerance for $\alpha = 34^\circ-38^\circ$				$\pm 1^\circ$	$\pm 30'$
Pulleys per b_2 per number of races z $b_2 = (z-1)e + 2f$		1	29	40	
		2	52	71	
		3	75	102	
		4	98	133	
		5	121	164	
		6	144	195	
		7	167	226	
		8	190	257	
		9	213	288	
		10	236	319	
		11	259	350	
		12	282	381	

The pulley's minimum diameter must be respected. Do not use for banded v-belts.

fig. 9

- Use high efficiency belts - for example **XPB** instead of **SPB**; this will allow to use a lower number of belts to transmit the same power, and consequently a minor distance of the resultant from the shaft shoulder (PTO) "a" in fig. 10.

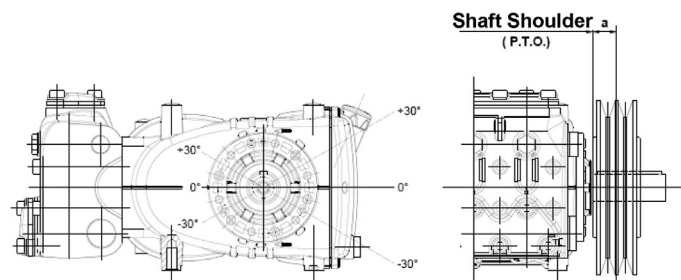
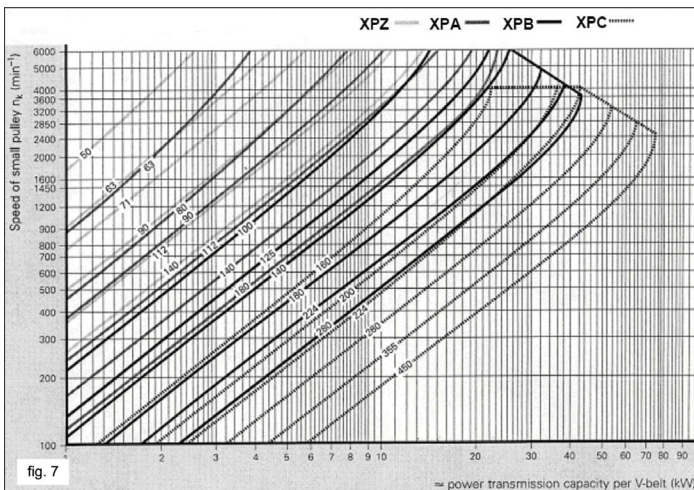

fig. 10



9.11 Transmission Definition

To avoid abnormal radial loads on the shaft and its related bearing, please comply with the following indications

- Use pulleys for v-belts with race dimensions prescribed/ recommended by the belt Manufacturer. Should no indications be supplied, please see fig. 8 and the table in fig. 9.

9.11 Transmission Definition (continued)

- c) Set belt tension according to the Manufacturer’s recommendations; an excessive value will abnormally stress the bearing, reduce its duration, and cause premature wear of the pulley. The tension value depends on different variables as indicated in paragraph 9.12.
- d) Belt length has a natural tolerance $\geq 0.75\%$; for this reason the belts must be purchased in sets.
- e) Follow the belt tension direction as indicated in fig. 9; for different needs, please contact the **Customer Service Department**.
- f) Carefully align driver pulley and driven pulley races.

9.12 Definition of Belt Static Tension Values

Static tension depends on:

- a) The center distance between the two pulleys (belt length).
- b) The load due to the belt’s static tension
- c) The number of belts
- d) The angle of wrap of the smallest pulley
- e) Average speed
- f) Etc.

The chart in fig. 11 shows the correct flexion of XPB belts according to their length, given a load of 75 N.

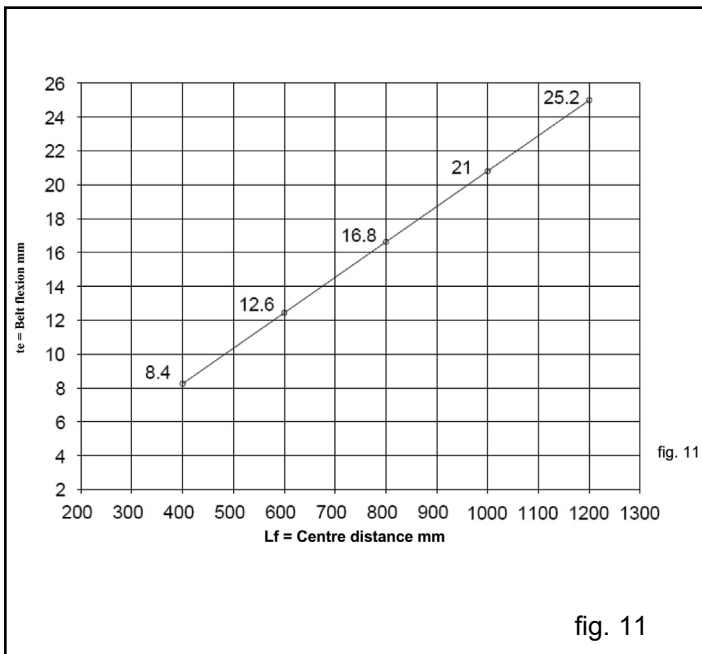

Conclusion: given a center distance (Lf) of 400 mm (15.75 inches) by applying a Fe load of 75 N at the middle of the length, the belt flexion “te” will result at about 8.4 mm (.33 inch).

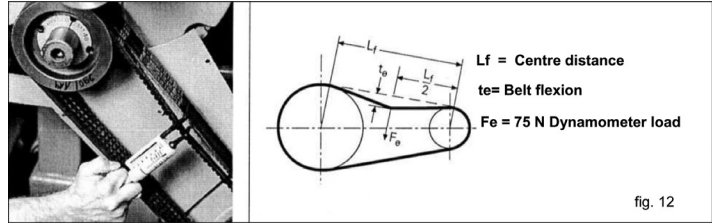

Note: If not differently indicated by the belt manufacturer, the inspection of the correct tension value, and the related tension adjustment if needed, is to be carried out after at least 30 minutes of operation in order to obtain belt settling. The best efficiency and maximum duration is obtained with a correct tension value.

If required, or during normal maintenance, never replace a single belt, but the entire set.

10.1 Preliminary Inspections

Before Start-up Be sure that:



The suction line is connected and up to pressure (see paragraphs 9.4-9.5-9.6) the pump must never run dry.

1. The suction line must be perfectly airtight.
2. All the On-Off valves between the pump and the feeding source are completely open. The delivery line must discharge freely in order to allow the air in the pump to be ex-pulsed easily, thus facilitating pump priming.
3. All suction/delivery connections and fittings must be correctly tightened.
4. Coupling tolerances on the pump/transmission axis (half-joint misalignment, Cardan inclination, belt tightening, etc.) must remain within the limits indicated by the transmission Manufacturer.
5. The oil level in the pump must be verified using the correct dipsticks (position 1, fig 13), and especially using the oil sight glass (position 2, fig. 13).

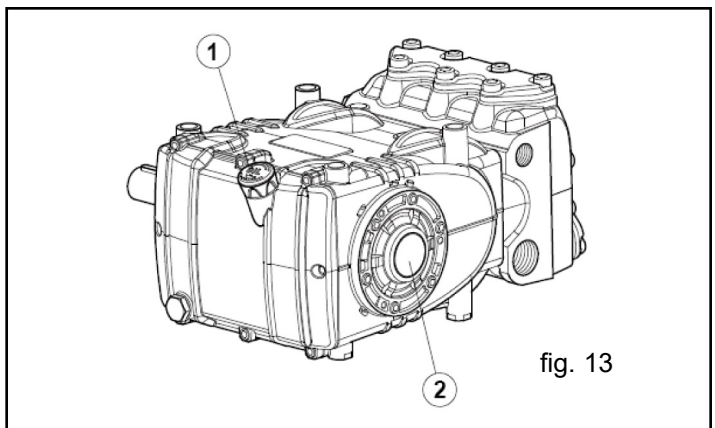



In case the pump has not run for a long period of time, verify the correct operation of the suction and delivery valves.

10.2 Start-up

1. When starting the pump for the first time, check for the correct direction of rotation.
2. The pump must be started off-load.
3. Verify correct feeding pressure.
4. During operation check that the rotating speed does not exceed the rated value.
5. Before putting the pump under pressure let it run for at least 3 minutes.
6. Before stopping the pump, release the pressure by acting on the adjustment valve or on any discharging device, and reduce RPM (diesel applications).

11. PREVENTIVE MAINTENANCE

To guarantee pump reliability and efficiency, respect the maintenance intervals as indicated in the table in fig. 14.

NOTE: Change oil after first 50 hour break-in period. After first 50-hour oil change, follow this schedule:

PREVENTIVE MAINTENANCE	
EVERY 500 HOURS	EVERY 1000 HOURS
Check oil level	Change oil
	Check / Replace: <ul style="list-style-type: none"> • Valves • Valve seats • Valve springs
	Check / Replace: <ul style="list-style-type: none"> • H.P packings • L.P. packings

fig. 14

12. STOPPING THE PUMP FOR LONG PERIODS



12.1 Inactivity for Long Periods

If the pump is started up for the first time after a long period from the shipment date, before starting operation check the oil level, check the valves as indicated in Chapter 10, and therefore follow the start-up procedures described.



12.2 After Use

After use the pump should be drained. The use of anti-freeze or preserving solutions is recommended. Any hose connection needing to be left disconnected should be properly protected and greased.

13. PRECAUTIONS AGAINST FREEZING



In areas and periods of the year where there is risk of freezing, follow the instructions indicated in Chapter 11 (see paragraph 12.2).



In the presence of ice, in no case must the pump be started until the entire circuit has been completely thawed out; not complying with this indication may cause serious damage to the pump.

14. WARRANTY TERMS

The duration and the terms of the warranty are contained in the purchase contract. The warranty is void if:

- a) The pump has been used for purposes that differ from that agreed.
- b) The pump has been fit with an electric or diesel engine with performance greater than that indicated in the table.
- c) The required safety devices were un-adjusted or disconnected.
- d) The pump was used with accessories or spare parts not supplied by General Pump.
- e) Damage was caused by:
 - 1) improper use
 - 2) the non-observance of maintenance instructions
 - 3) use not compliant with operating instructions
 - 4) insufficient flow rate
 - 5) faulty installation
 - 6) incorrect positioning or sizing of the hoses
 - 7) non-authorized design changes
 - 8) cavitation

15. TROUBLESHOOTING



The pump does not produce any noise at start-up:

- The pump is not primed and is running dry
- There is no water in the inlet line
- The valves are blocked
- The delivery line is closed and does not allow the air in the pump to be discharged



The pump pulses irregularly (knocking):

- Air suction
- Insufficient feeding
- Bends, elbows, fittings along the suction line obstruct the fluid's passage
- The inlet filter is dirty or too small
- The booster pump, where provided, supplies insufficient pressure or flow rate
- The pump is not primed due to insufficient head or the delivery line is closed during priming

15. TROUBLESHOOTING (continued)



The pump pulses irregularly (knocking):(cont)

- The pump is not primed due to valve seizing
- Worn valves
- Worn pressure packings
- Incorrect operation of the pressure adjustment valve
- Transmission problems



The pump does not deliver the rated flow / is noisy:

- Insufficient feeding (see the causes listed above)
- RPM are less than the rated flow
- Excessive amount of water by-passed by the pressure adjustment valve



- Worn valves
- Leakage from the pressure packings
- Cavitation due to:
 - 1) Wrong sizing of the suction hose/undersized diameters
 - 2) Insufficient flow rate
 - 3) High water temperature

Insufficient pump pressure:



- The nozzle (or has become)too large
- Insufficient RPM
- Leakage from the pressure packings
- Incorrect operation of the pressure adjustment valve
- Worn valves

Overheated pump:



- The pump is overloaded (pressure or RPM exceed the rated values)
- Oil level is too low, or the oil is not of a suitable type, indicated in Chapter 11 (see paragraph 11.1.1)
- Excessive belt tension or incorrect alignment of the joint or the pulleys
- Excessive inclination of the pump during operation

Hose vibrations or knocking:



- Air suction
- Incorrect operation of the pressure adjustment valve
- Valve malfunction
- Irregular drive transmission motion

16. EXPLODED VIEW AND PARTS LIST

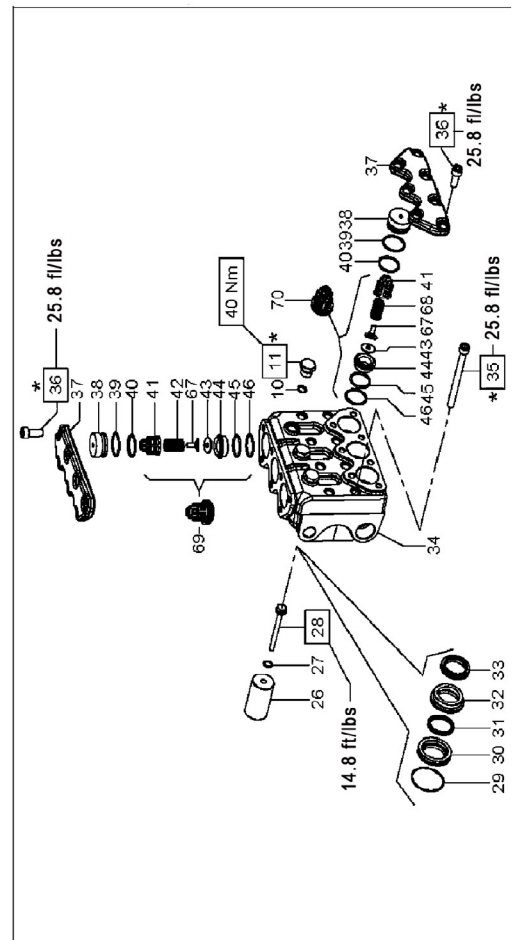
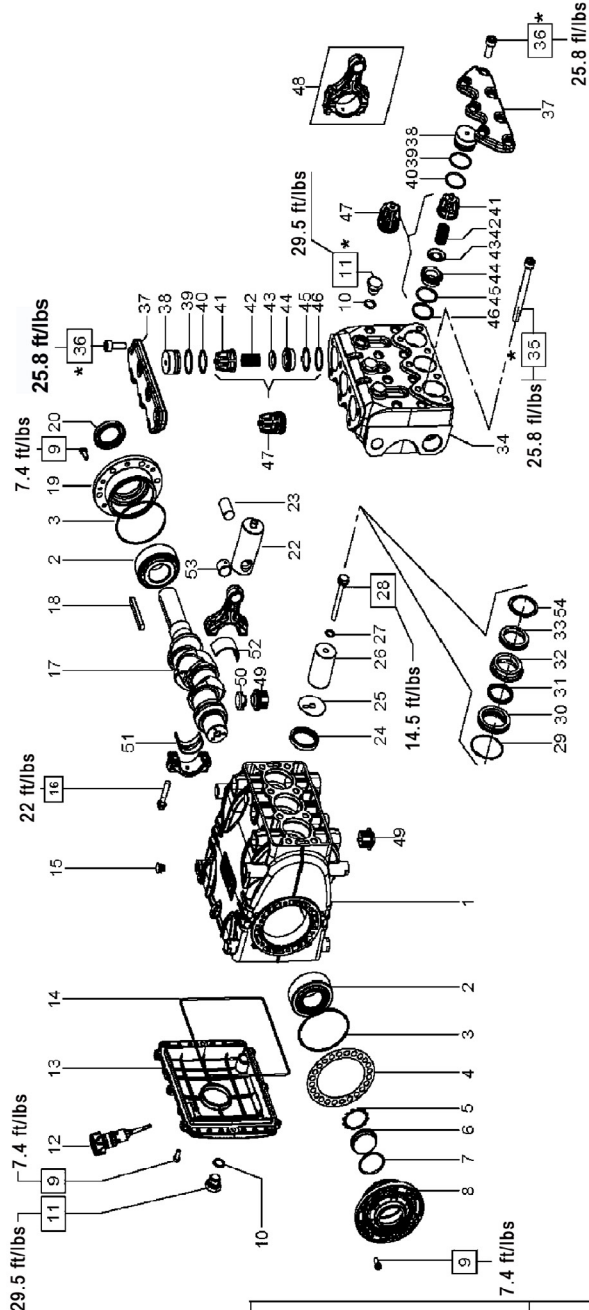

<p>Hydraulic Motor Flange</p> <p>OPTIONAL</p> <p>29.5 ft/lb</p>	<p>Auxiliary PTO</p> <p>OPTIONAL</p> <p>7.4 ft/lb</p> <p>107 ft/lbs (lubricate with Blue Loctite 243)</p>	<p>Flushing Manifold</p> <p>OPTIONAL</p> <p>IN</p> <p>OUT</p>
--	--	--

Item	Part #	Description	QTY.
1	F70010022	Crankcase	1
2	F91847700	Roller bearing	2
3	F90391500	O-ring Ø 80.6 x 2.62	2
4	F70220081	Shim 0.1mm	
	F70220381	Shim .25 mm	
5	F90075600	Ring	1
6	F70211801	Oil level indicator	1
7	F90387700	O-ring Ø 39.34 x 2.62	1
8	F70150122	Oil level indicator side bearing cover	1
9	F99185200	Screw M6 x 16	20
10	F90383300	O-ring Ø 13.95 x 2.62 (KEZ36HA)	4
	F90358500	O-ring Ø 10.82 x 2.62	
11	F98210066	Plug G3/8" x 13 (KEZ36HA)	4
	F98204666	Plug, G1/4"x13	
12	F98211500	Dipstick	1
13	F70160022	Crankcase cover	1
14	F90394200	O-ring Ø 190.17 x 2.62	1
15	F98200500	Plug for Ø 15 port	7
16	F99312300	Connecting rod screw	6
17	F70020035	Crankshaft	1
18	F91490000	Crankshaft key	1
19	F70150022	Motor side bearing cover	1
20	F90166800	Oil seal 35 x 52 x 7 Spec.	1
22	F70050015	Piston guide	3
23	F97742000	Pin Ø 18 x 36	3
24	F90167700	Seal 36 x 47 x 7	3
25	F96709900	Wiper	3
26	F70040009	Plunger, Ø20, KEZ20A	3
	F70040109	Plunger, Ø22, KEZ22A	3
	F70040209	Plunger, Ø24, KEZ24A	3
	F70040309	Plunger, Ø28, KEZ28HA	3
	F70040409	Plunger, Ø30, KEZ30HA	3
	F70040509	Plunger, Ø36, KEZ36HA	3
27	F90367100	O-ring Ø 11 x 2 Spec.	3
28	F70221866	Plunger bolt, SS	3
29	F90362600	O-ring Ø 50.52 x 1.78	3
30	F70081566	Packing retainer, Ø20, KEZ20A	3
	F70081666	Packing retainer, Ø22, KEZ22A	3
	F70081366	Packing retainer, Ø24, KEZ24A	3
	F70081166	Packing retainer, Ø28, KEZ28HA	3
	F70081466	Packing retainer, Ø30, KEZ30HA	3
	F70081066	Packing retainer Ø 36, SS, KEZ36HA	3
31	F90225000	L.P. packing, Ø20, KEZ20A	3
	F90230000	L.P. packing, Ø22, KEZ22A	3
	F90235000	L.P. packing, Ø24, KEZ24A	3
	F90238100	L.P. packing, Ø28, KEZ28HA	3
	F90275950	L.P. packing, Ø30, KEZ30HA	3
	F90240000	L.P. packing, Ø 36, KEZ36HA	3
32	F70223666	Intermediate ring, Ø20, KEZ20A	3
	F70223866	Intermediate ring, Ø22, KEZ22A	3
	F70222666	Intermediate ring, Ø24, KEZ24A	3
	F70222066	Intermediate ring, Ø28, KEZ28HA	3
	F70223566	Intermediate ring, Ø30, KEZ30HA	3
	F70221766	Intermediate ring, Ø36, KEZ36HA	3

Item	Part #	Description	QTY.
33	F90226200	H.P. packing, Ø20, KEZ20A	3
	F90231000	H.P. packing, Ø22, KEZ22A	3
	F90236400	H.P. packing, Ø24, KEZ24A	3
	F90238000	H.P. packing, Ø28, KEZ28HA	3
	F90277100	H.P. packing, Ø30, KEZ30HA	3
	F90241000	H.P. packing, Ø 36, KEZ36HA	3
34	F70125336	Manifold, SS, Ø20, KEZ20A	1
	F70124036	Manifold, SS, Ø22-24, KEZ22A & KEZ24A	1
	F70125436	Manifold, SS, Ø28-30, KEZ28Z & KEZ30HA	1
	F70123636	Manifold, SS, Ø36 KEZ36HA	1
35	F99381800	Screw, M10 x 110	8
36	F99367000	Screw, M10 x 25 Spec.	14
37	F70221536	Valve cover, SS	2
38	F70221666	Valve plug, SS, KEZ20A, KEZ22A, KEZ24A	6
	F70222166	Valve plug, SS, KEZ28HA, KEZ30HA, KEZ36HA	6
39	F90518000	Back-up ring, Ø 32.4 x 36.5 x 1.5	6
40	F90386500	O-ring, Ø 29.82 x 2.62	6
41	F36209751	Suction/delivery valve guide, KEZ20A, KEZ22A, KEZ24A	6
	F36204751	Suction/delivery valve guide, KEZ28HA, KEZ30HA, KEZ36HA	6
42	F94740100	Delivery valve spring, KEZ20A, KEZ22A, KEZ24A	6
	F94745000	Delivery valve spring, KEZ28HA, KEZ30HA, KEZ36HA	6
43	F36201076	Suction/delivery valve plate, KEZ20A, KEZ22A, KEZ24A	6
	F36209866	Suction/delivery valve plate, KEZ28HA, KEZ30HA, KEZ36HA	6
44	F36209466	Suction/delivery valve seat, KEZ20A, KEZ22A, KEZ24A	6
	F36207066	Suction/delivery valve seat, KEZ28HA, KEZ30HA, KEZ36HA	6
45	F90386500	O-ring, 29.82 x 2.62	6
46	F90517800	Anti-extrusion Ring, Ø 31 x 35.5 x 1.5	6
47	F36715401	Delivery valve assembly	6
48	F70030501	Connecting rod assembly	3
49	F70222551	Crankcase Plug	6
50	F71225951	Vented Cap	3
51	F90922000	Babbitt Bearing, Sup.	3
	F90922100	Babbitt Bearing, Sup., +0.25	3
	F90922200	Babbitt Bearing, Sup., +0.50	3
52	F90922300	Babbitt Bearing, Inf.	3
	F90922400	Babbitt Bearing, Inf. +0.25	3
	F90922500	Babbitt Bearing, Inf., +0.50	3
53	F90910000	Bronze Bushing	3
54	F70223766	Seal	3
	F70222266	Seal	3
57	F99313600	Screw, M8x45	6
58	F10075547	Flexible Joint, Pump	1
59	F10743001	Flexible Joint, Motor	1
60	F10075220	Hydraulic Motor Flange	1
61	F70020535	Crankshaft, PTP	1
62	F97615200	Pin, Ø 5x10	1
63	F70223454	Auxiliary PTO	1
64	F96716000	Washer, Ø 12,18x1	1
65	F99429500	Screw, M12x35	1
66		Flushing Manifold	1
67	F36210151	Internal Valve Guide	6
68	F94739700	Spring	3
69	F36716701	Outlet Valve Assembly	3
70	F36716601	Inlet Valve Assembly	3
71	F98206000	Plug, Ø 15	2
	99426600	Feet Bolts, M12-1.75 x 22, Optional	4
	96719500	Feet Serrated Washer, M12, Optional	4

REPAIR KITS

Pump Model	KEZ20A	KEZ22A	KEZ24A	KEZ28HA	KEZ30HA	KEZ36HA
Plunger Packing Kit Item Nos: 31, 33	K238	K202	F2170	F2119	F2204	K212
Inlet Valve Kit Item Nos: 47, 70	F2120	F2120	F2120	F2040	F2040	F2040
Outlet Valve Kit Item Nos: 47, 69	F2121	F2121	F2121			
Complete Seals Kit Item Nos: 3, 5, 7, 10, 14, 20, 24, 27, 29, 31, 33, 39, 40, 45, 46	F2211	F2212	F2171	F2122	F2213	F2041
Conrod Bushing Kit Item Nos: 51, 52	F 2156 (STD), F2157 (+0.25), F2158 (+0.50)					

Ref 300665 Rev. F
02-24

MAINTENANCE LOG

HOURS & DATE

OIL CHANGE							
GREASE							
PACKING REPLACEMENT							
PLUNGER REPLACEMENT							
VALVE REPLACEMENT							



GENERAL PUMP

GP Companies, Inc.
1174 Northland Drive
Mendota Heights, MN 55120
Phone: 651.686.2199 Fax: 800.535.1745
www.generalpump.com email: sales@gpcompanies.com

Ref 300665 Rev. F
02-24