

FEATURES

- Features patented “high tech” packings:
 - dynamic low-pressure seal retainer
 - superior low-pressure seal
 - innovative intermediate ring
 - superior high-pressure seal
- Ceramic plungers
- Patent-pending inlet/outlet valve seal
- Patent-pending inlet/outlet valve cage
- Nickel-plated inlet/outlet valve plugs
- Nickel-plated forged brass manifold
- Heavy-duty tapered roller bearings
- Specifically designed to handle rigorous duty cycles, high temperatures and chemicals
- Ideal for use in carpet cleaning and other high pressure cleaning applications



SPECIFICATIONS

Pump Model	HTS2210S	HTS2212S	HTS2215S
Maximum Volume	4.0 GPM	4.75 GPM	4.0/5.0 GPM
Maximum Pressure	2300 PSI		
Maximum RPM	1450 RPM		950/1200 RPM
Maximum Inlet Pressure	125 PSI		
Minimum Inlet Pressure	9 ft. water (7.9 in. Hg)		
Maximum Fluid Temperature	185°F		
Bore (in / mm)	.866 in. / 22 mm		
Stroke (in / mm)	.394 in. / 10 mm	.472 in. / 12 mm	.591 in. / 15 mm
Oil Capacity	40.6 oz.		
Inlet Port Thread	1/2"-14 BSP-F		
Discharge Port Thread	3/8"-19 BSP-F		
Shaft Diameter	.945 in. / 24 mm		
Weight	32 lbs.		
Dimensions - Nominal	12.4" x 10.0" x 6.9"		

Instructions and Recommendations for the Installation of *HT Series Pumps*

The high-temperature pumps of the HT series have been designed for use in applications where the water must be pre-heated, such as in carwash, food and pharmaceutical industries.

Maximum temperature of the water through the pump is 185°F (85°C).

In order to obtain maximum performance in terms of duration of seals and valves, it is necessary to respect a few simple rules, as follows:

1) In order to avoid damage caused by cavitation, the pump must be pressure fed.

The higher the inlet pressure, the longer the life of the wet end of the pump.

When working at 185°F (85°C), the minimum feed pressure - measured directly in the inlet port of the pump when it is working - is 45 psi (3 bar).

The minimum feed pressure according to the different temperatures are:

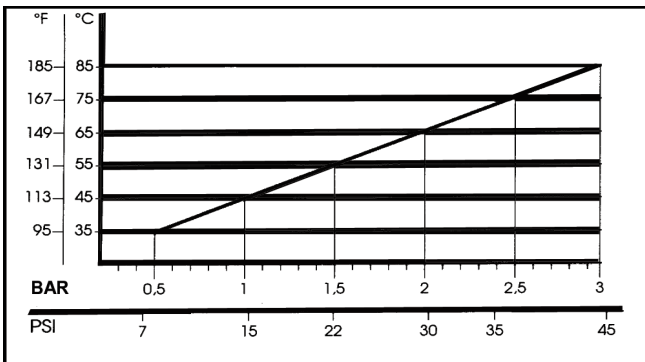

Naturally, if the application allows for feeding the pump with 45 psi (3 bar) even at low temperatures (for example: 115°F/45°C the life of the wet end of the pump will be even longer.

2) The plumbing which feeds the pump must be of a diameter at least equal to the inlet port.

Also, follow the suggestions below:

a) Make the plumbing as short and straight as possible, preferably in an upward direction to facilitate the expulsion of eventual air bubbles naturally if compatible with the requirements of the system.

b) It is always useful to put a filter at the inlet with capacity of 4 to 5 times the flow of

the pump, for example for a 4 gpm (15 l/min) pump, put a filter from 16 to 20 gpm (60-75 l/min). The mesh size suitable for this application is 0.016" (.4 mm).

c) It is extremely important to put a pressure switch on the suction port of the pump, and in any case downstream from the filter, so that it can stop the pump should the feed pressure drop by 20% due to the filter clogging or failure of the feed pump, etc.

3) Change of oil

We recommend the **first oil change after the first 50 hours**, with the **pump stopped** and the **oil still warm**.

This change is not recommended because the oil has lost its properties, but rather to eliminate the impurities that have gotten into the oil during the running-in phase. If these impurities are not removed, but are allowed to remain in the oil, they may cause premature wear to the moving parts and the oil seals. **After this initial change, the oil can then be changed every three months or 300 hours of operation thereafter.**

Please note: If the pump works in conditions with high humidity and with sharp temperature changes, it is possible that condensation will appear inside the crankcase, which mixing with the oil can change its properties. This is easy to see because the oil changes to a white, milky color.

If the pump does not have excessive water leaking from the packings, and the oil becomes milky, the oil has to be changed more frequently. The percentage of water in the oil must not exceed 20%.

Use oil per the following chart:

CHART OF COMPATIBLE OILS	
GENERAL PUMP	SERIES 100
BP	VISCO 2000
CASTROL	CWX
MOBIL	SUPER
SHELL	HELIX SUPER
TOTAL	QUARTZ 4000-5000

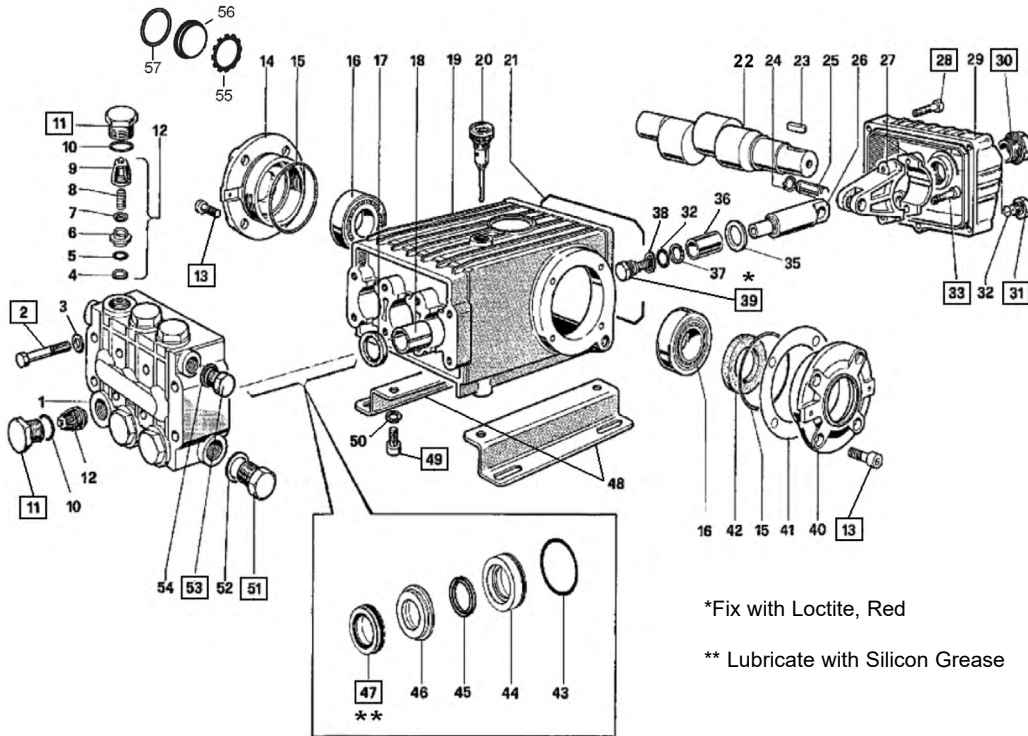

*Fix with Loctite, Red

** Lubricate with Silicon Grease

PARTS LIST

ITEM	PART NO.	DESCRIPTION	QTY	ITEM	PART NO.	DESCRIPTION	QTY	ITEM	PART NO.	DESCRIPTION	QTY
1.	47120941	Manifold, Nickel-plated, 22mm	1	20.	98210600	Dipstick, Vented	1	38.	96728000	Washer, M14	3
2.	99320600	Head Bolt, M8	8	21.	90392200	O-ring	1	39.	47219566	Plunger Screw	3
3.	203476	Washer, M8	8	22.	47021935	Crankshaft, HTS2210S	1	40.	47151022	Crankcase Cover, Open	1
4.	90510500	Anti-extrusion ring	6		47021835	Crankshaft, HTS2212S		41.	97567800	Spacer	2
5.	90340000	Seal Ring	6		47022435	Crankshaft, HTS2215S		42.	90164800	Crankshaft Oil Seal	1
6.	36200366	Valve Seat	6	23.	91489200	Key	1	43.	90361600	O-ring	3
7.	36200176	Valve	6	24.	90055700	Circlip	6	44.	47081470	Seal Retainer, 22mm	3
8.	94737600	Valve Spring	6	25.	97738000	Wrist Pin	3	45.	90230000	L.P. Seal, 22mm	3
9.	36200251	Valve Guide	6	26.	47050455	Plunger Guide	3	46.	47217570	Intermed. Ring, 22mm	3
10.	701002	O-ring	6	27.	47030001	Connecting Rod	3	47.	90231000	H.P. Seal, 22mm	3
11.	98222200	Valve Cap, Nickel-plated	6	28.	99191200	Screw, M6	5	48.	47200074	Pump Rail	2
12.	36704901	Valve, Complete	6	29.	47160100	Crankcase Cover, Rear	1	49.	99364400	Screw, M10	4
13.	99303900	Screw, M8	8	30.	97596800	Oil Level Indicator	2	50.	96710600	Washer, M10	4
14.	47151222	Side Cover	1	31.	98204100	Plug, 1/4"	1	51.	98217900	Plug, Nickel-plated, G1/2"	1
15.	701147	O-ring	2	32.	701013	O-ring	4	52.	96751400	Washer, M21.5	1
16.	640047	Bearing, Tapered Roller	2	33.	99309900	Screw, M6	6	53.	98209900	Plug, Nickel-plated, G3/8"	1
17.	90162500	Plunger Rod Oil Seal	3	35.	96728600	Flinger Washer	3	54.	96738000	Washer, M17.5	1
18.	90912600	Guide, Bushing	3	36.	47040509	Plunger, 22mm	3	55.	90075600	Retainer Clip	1
19.	47010022	Crankcase	1	37.	660067	Back-up Ring	3	56.	70211801	Oil Sight Glass	1
								57.	90387700	O-ring, 39.34 x 2.62	1

REPAIR KITS

KIT NO.	K02	K03	K05	K06	K201	K202	K203
ITEM NO'S INCLUDED IN KIT	17	42	10, 11	32, 35, 37, 38, 39	4, 5, 6, 7, 8, 9 (12)	45, 47	43, 44, 45, 46, 47
NUMBER OF ASSY'S IN KIT	3	2	6	3	6	3	1
NO. OF CYLINDERS KIT SERVICES	3	-	3	3	3	3	1

TORQUE SPECS*

Position	Ft.-Lbs.	Nm.
2	22.1	30
11	95.9	130
13	14.7	20
28	7.3	10
30	8.9	12
31	14.7	20
33	14.7	20
39**	14.7	20
49	29.4	40
51	29.4	40
53	29.4	40

DIMENSIONS

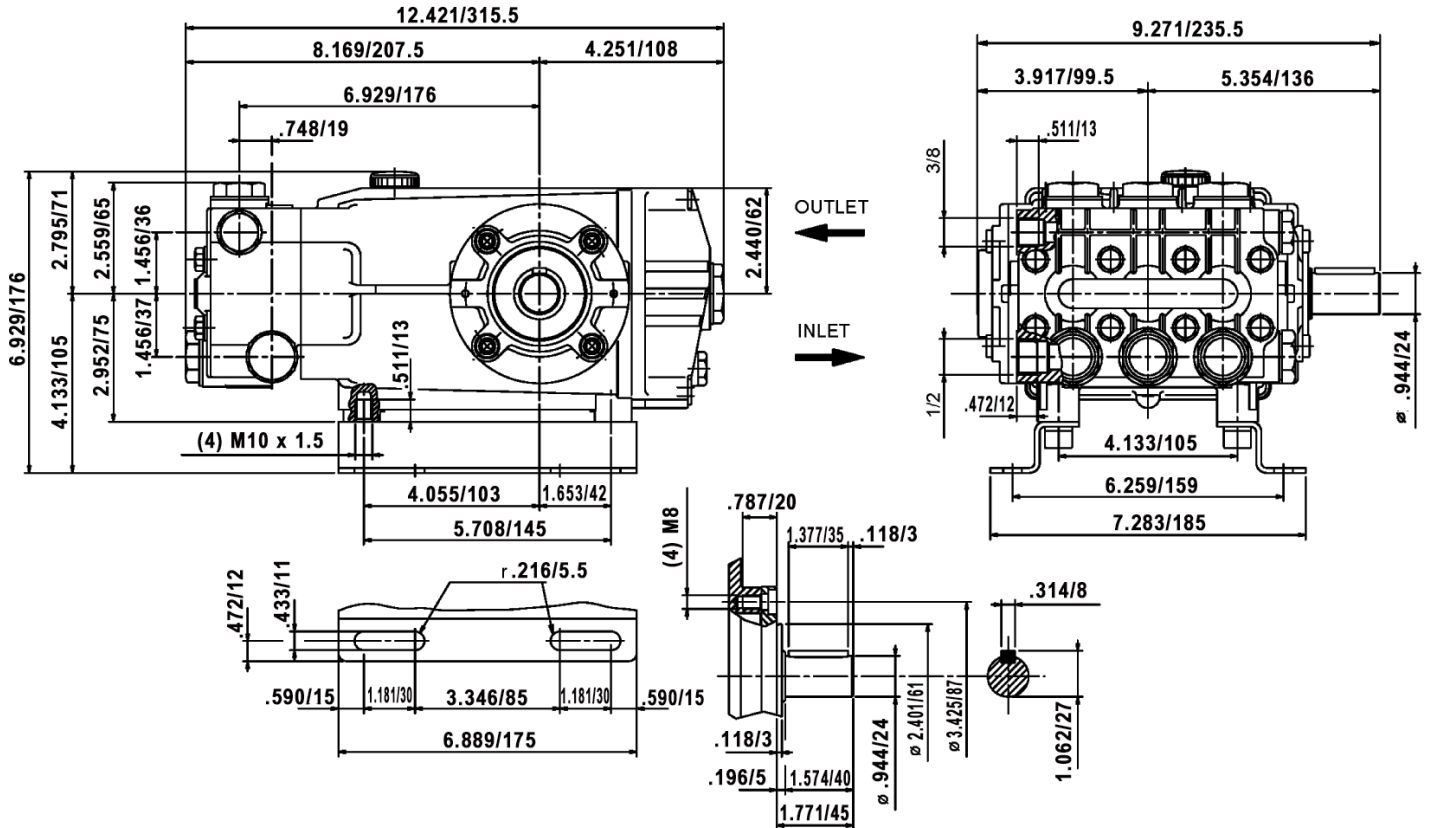

WARNINGS

WARNING: High Pressure Systems require a primary pressure regulating device (i.e. regulator, unloader) and a secondary pressure relief device (i.e. pop-off valve, relief valve). Failure to install such relief devices properly could result in personal injury or damage to pump or property. GP does not assume any liability or responsibility for the operation of the user's high pressure system.

 **WARNING:** This product can expose you to chemicals including lead, which is know to the state of California to cause cancer and birth defects or other reproductive harm. For more information, go to www.P65Warnings.ca.gov