

EMPEROR

FEATURES

- Features patent-pending “high tech” packings:
 - dynamic low-pressure seal retainer
 - superior low-pressure seal
 - innovative intermediate ring
 - superior high-pressure seal
- Ceramic plungers
- Patent-pending inlet/outlet valve cage
- Nickel-plated inlet/outlet valve plugs
- Nickel-plated forged brass manifold
- Designed for carpet cleaning and for use in industrial plant systems where hot water is required

SPECIFICATIONS

Pump Model	HTF2019S	HTF2221S	HTF2421S
Maximum Volume	7.5 GPM	10.2 GPM	10.0/12.0 GPM
Maximum Pressure	3600 PSI	3000 PSI	3000/2500 PSI
Maximum RPM	1750 RPM		1450/1750 RPM
Maximum Inlet Pressure	125 PSI		
Minimum Inlet Pressure	9 ft. water (7.9 in. Hg)		
Maximum Fluid Temperature	185°F		
Bore (in / mm)	.787 in. / 20 mm	.866 in. / 22 mm	.945 in. / 24 mm
Stroke (in / mm)	.748 in. / 19 mm	.826 in. / 21 mm	
Oil Capacity	40.6 oz.		
Inlet Port Thread	3/4"-14 BSP-F		
Discharge Port Thread	3/8"-19 BSP-F		
Shaft Diameter	.945 in. / 24 mm		
Weight	41 lbs.		
Dimensions - Nominal	13.4" x 9.8" x 7.5" (with rails)		13.4" x 9.8" x 6.4" (no rails)

EMPEROR

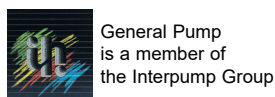

Instructions and Recommendations for the Installation of *HT Series Pumps*

The high-temperature pumps of the HT series have been designed for use in applications where the water must be pre-heated, such as in carwash, food and pharmaceutical industries.

Maximum temperature of the water through the pump is 185°F (85°C).

In order to obtain maximum performance in terms of duration of seals and valves, it is necessary to respect a few simple rules, as follows:

1) In order to avoid damage caused by cavitation, the pump must be pressure fed.

The higher the inlet pressure, the longer the life of the wet end of the pump.

When working at 185°F (85°C), the minimum feed pressure - measured directly in the inlet port of the pump when it is working - is 45 psi (3 bar).

The minimum feed pressure according to the different temperatures are:

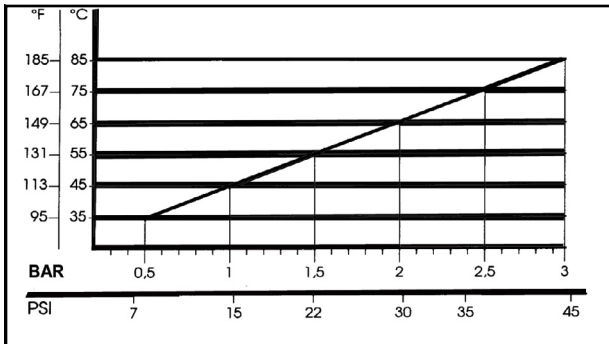

Naturally, if the application allows for feeding the pump with 45 psi (3 bar) even at low temperatures (for example: 115°F/45°C the life of the wet end of the pump will be even longer.

2) The plumbing which feeds the pump must be of a diameter at least equal to the inlet port.

Also, follow the suggestions below:

a) Make the plumbing as short and straight as possible, preferably in an upward direction to facilitate the expulsion of eventual air bubbles naturally if compatible with the requirements of the system.

b) It is always useful to put a filter at the inlet with capacity of 4 to 5 times the flow of

the pump, for example for a 4 gpm (15 l/min) pump, put a filter from 16 to 20 gpm (60-75 l/min). The mesh size suitable for this application is 0.016" (.4 mm).

c) It is extremely important to put a pressure switch on the suction port of the pump, and in any case downstream from the filter, so that it can stop the pump should the feed pressure drop by 20% due to the filter clogging or failure of the feed pump, etc.

3) Change of oil

We recommend the **first oil change after the first 50 hours**, with the **pump stopped** and the **oil still warm**.

This change is not recommended because the oil has lost its properties, but rather to eliminate the impurities that have gotten into the oil during the running-in phase. If these impurities are not removed, but are allowed to remain in the oil, they **may cause premature wear** to the moving parts and the oil seals. **After this initial change, the oil can then be changed every three months or 300 hours of operation thereafter.**

Please note: If the pump works in conditions with high humidity and with sharp temperature changes, it is possible that condensation will appear inside the crankcase, which mixing with the oil can change its properties. This is easy to see because the oil changes to a white, milky color.

If the pump does not have excessive water leaking from the packings, and the oil becomes milky, the oil has to be changed more frequently. The percentage of water in the oil must not exceed 20%.

Use oil per the following chart:

BRAND	TYPE
GENERAL PUMP	SERIES 220
BP	ENERGOL HLP 220
CASTROL	Hyspin VG220, Magna 220
MOBIL	DTE OIL BB
SHELL	TELLUS C 220
TOTAL	CORTIS 220

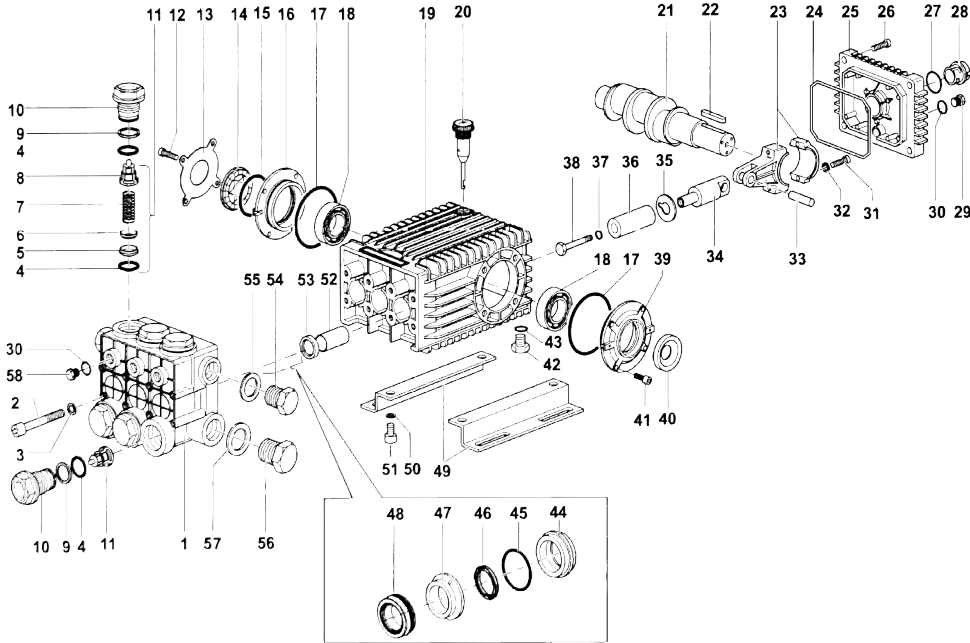

PARTS LIST

ITEM	PART NO.	DESCRIPTION	QTY	ITEM	PART NO.	DESCRIPTION	QTY	ITEM	PART NO.	DESCRIPTION	QTY	
1.	66120641	Manifold, Nickel Plated, 20mm	1	22.	91489200	Key	1	66081470	Seal Retainer. 24mm			
	66120741	Manifold, Nickel Plated, 22mm		23.	66030001	Connecting Rod	3	90361600	O-ring	3		
	66120841	Manifold, Nickel Plated, 24mm		24.	90392200	O-ring	1	90225000	L.P. Seal, 20mm	3		
2.	99380100	Head Bolt, M10	8	25.	66160022	Crankcase Cover, Rear	1	90230000	L.P. Seal, 22mm			
3.	96710400	Washer, M10	8	26.	99188400	Screw, M6	4	90235000	L.P. Seal, 24mm			
4.	90385700	O-ring	12	29.	98204100	Plug, 1/4"	1	47.	66216070	Intermed. Ring, 20mm	3	
5.	36203366	Valve Seat	6	30.	90358500	O-ring	4	66216170	Intermed. Ring, 22mm			
6.	36203476	Valve Poppet	6	31.	99309900	Screw, M8	6	66216470	Intermed. Ring, 24mm			
7.	94738800	Valve Spring	6	32.	96701400	Lock Washer, M8.4	6	48.	90226000	H.P. Seal, 20mm	3	
8.	36203551	Valve Guide	6	33.	97740500	Wrist Pin	3	90231200	H.P. Seal, 22mm			
9.	90516500	Anti-extrusion ring	6	34.	66050064	Plunger Guide	3	90236000	H.P. Seal, 24mm			
10.	66130341	Valve Cap, Nickel Plated	6	35.	96710100	Flinger Washer	3	49.	47200074	Pump Rail	2	
11.	36712701	Valve, Complete	6	36.	66040009	Plunger, 20mm	3	50.	96710600	Washer, M10	4	
12.	99306900	Screw, M8	4	66040109	Plunger, 22mm		51.	99364400	Screw, M10	4		
13.	66150274	Cover	1	66040409	Plunger, 24mm		52.	90912600	Guide Bushing	3		
14.	44211801	Oil Level Indicator	1	37.	90358400	O-ring	3	53.	90162500	Plunger Rod Oil Seal	3	
15.	90409700	O-ring	1	38.	66219566	Plunger Bolt	3	54.	98209900	Plug, G3/8", Nickel-plated	1	
16.	66150122	Side Cover	1	39.	66150022	Crankcase Cover, Open	1	55.	96738000	Aluminum Washer	1	
17.	90391300	O-ring	2	40.	90164800	Crankshaft Seal	1	56.	98226900	Plug, G3/4", Nickel-plated	1	
18.	91838000	Bearing, Cylindrical Roller	2	41.	99303900	Screw, M8	4	57.	96770000	Aluminum Washer	1	
19.	66010022	Crankcase	1	42.	98210000	Plug, 3/8"	1	58.	98204700	Plug, G1/4", Nickel-plated	3	
20.	98210600	Dipstick, Vented	1	43.	90383300	O-ring ¹						
21.	66020035	Crankshaft, HTF2019S	1	44.	66081270	Seal Retainer, 20mm	3					
	66020435	Crankshaft, HTF2221S/HTF2421S		66081370	Seal Retainer. 22mm							

REPAIR KITS

Kit No.	HTF Series								
	K02	K03	K169	K206	K207	K208	K209	K210	K211
Item No's Included in Kit	53	40	4, 5, 6 7, 8 (11)	46, 48	44, 45 46, 47 48	46, 48	44, 45 46, 47 48	46, 48	44, 45, 46, 47, 48
Number of Assemblies In Kit	3	2	6	3	1	3	1	3	1
Number of Cylinders Kit Services	3	-	3	3	1	3	1	3	1

TORQUE SPECS*

Position	Ft.-Lbs.	Nm.
2	33.2	45
10	95.9	130
12	14.7	20
26	7.3	10
29	14.7	20
31	14.7	20
38**	14.7	20
41	14.7	20
42	29.4	40
51	29.4	40
54	29.4	40
56	51.6	70

*Decrease torque by 20% if threads are lubricated.
**Use Loctite 542

DIMENSIONS

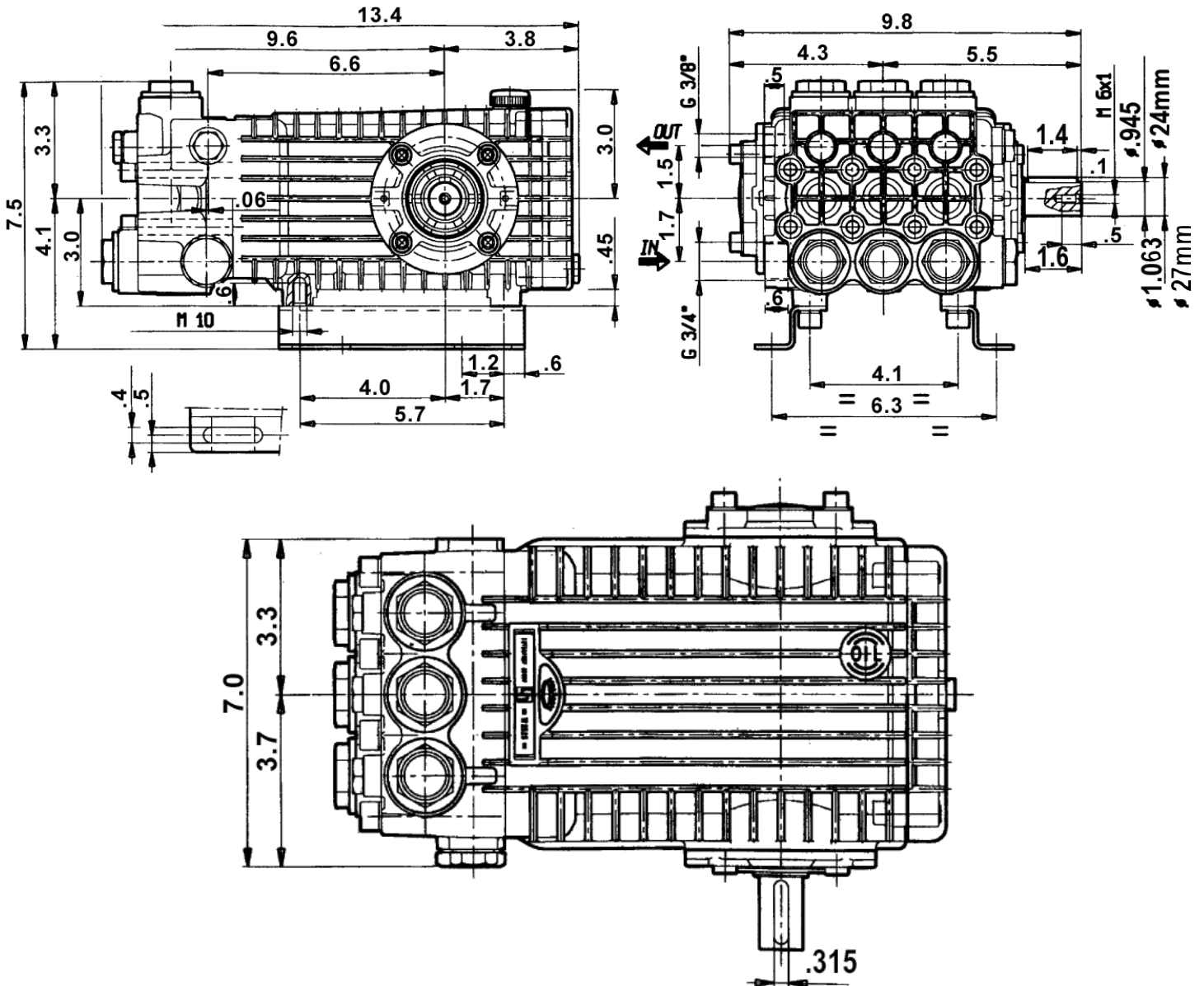

WARNING: High Pressure Systems require a primary pressure regulating device (i.e. regulator, unloader) and a secondary pressure relief device (i.e. pop-off valve, relief valve). Failure to install such relief devices properly could result in personal injury or damage to pump or property. GP does not assume any liability or responsibility for the operation of the user's high pressure system.



WARNING: This product can expose you to chemicals including lead, which is known to the state of California to cause cancer and birth defects or other reproductive harm. For more information, go to www.P65Warnings.ca.gov

