

## FEATURES

- Features patent-pending “high tech” packings:
  - dynamic low-pressure seal retainer
  - superior low-pressure seal
  - innovative intermediate ring
  - superior high-pressure seal
- Ceramic plungers
- Patent-pending inlet/outlet valve cage
- Nickel-plated forged brass manifold
- Heavy-duty tapered roller bearings
- Specifically designed to handle rigorous duty cycles, high temperatures and chemicals
- Ideal for use in car wash and other high pressure cleaning applications

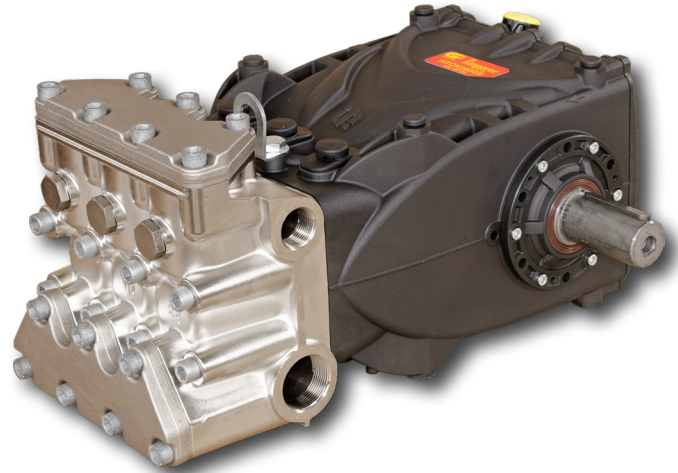

## SPECIFICATIONS

Pump Model	HTCK4050S	
Maximum Volume	40.0 GPM	45.0 GPM
Maximum Pressure	1500 PSI	
Maximum RPM	800 RPM	900 RPM
Horsepower	41.1 HP	46.2 HP
Maximum Inlet Pressure	125 PSI	
Minimum Inlet Pressure	3 ft. water (2.6 in. Hg)	
Maximum Fluid Temperature	185°F	
Bore (in / mm)	1.6 in./40 mm	
Stroke (in / mm)	1.9 in./50 mm	
Oil Capacity	124.4 oz. - Use GP 220 Series Oil	
Inlet Port Thread	1-1/2"-11 NPT-F	
Discharge Port Thread	1"-11 NPT-F	
Shaft Diameter	1.9 in./40 mm	
Weight	157 lbs.	
Dimensions - Nominal	20.7" x 14.5" x 9.9"	



# Instructions and Recommendations for the Installation of *HT Series Pumps*

The high-temperature pumps of the HT series have been designed for use in applications where the water must be pre-heated, such as in carwash, food and pharmaceutical industries.

Maximum temperature of the water through the pump is 185°F (85°C).

In order to obtain maximum performance in terms of duration of seals and valves, it is necessary to respect a few simple rules, as follows:

1) **In order to avoid damage caused by cavitation, the pump must be pressure fed.**

The higher the inlet pressure, the longer the life of the wet end of the pump.

When working at 185°F (85°C), the minimum feed pressure - measured directly in the inlet port of the pump when it is working - is 45 psi (3 bar).

The minimum feed pressure according to the different temperatures are:

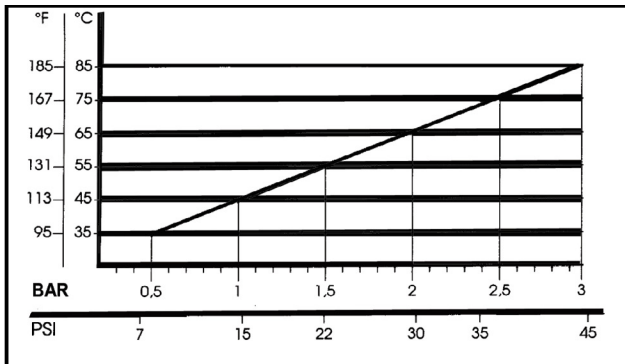

Naturally, if the application allows for feeding the pump with 45 psi (3 bar) even at low temperatures (for example: 115°F/45°C the life of the wet end of the pump will be even longer.

2) **The plumbing which feeds the pump must be of a diameter at least equal to the inlet port.**

Also, follow the suggestions below:

a) Make the plumbing as short and straight as possible, preferably in an upward direction to facilitate the expulsion of eventual air bubbles naturally if compatible with the requirements of the system.

b) It is always useful to put a filter at the inlet with capacity of 4 to 5 times the flow of

the pump, for example for a 4 gpm (15 l/min) pump, put a filter from 16 to 20 gpm (60-75 l/mi). The mesh size suitable for this application is 0.016" (.4 mm).

c) It is extremely important to put a pressure switch on the suction port of the pump, and in any case downstream from the filter, so that it can stop the pump should the feed pressure drop by 20% due to the filter clogging or failure of the feed pump, etc.

3) **Change of oil**

We recommend the **first oil change after the first 50 hours**, with the **pump stopped** and the **oil still warm**.

This change is not recommended because the oil has lost its properties, but rather to eliminate the impurities that have gotten into the oil during the running-in phase. If these impurities are not removed, but are allowed to remain in the oil, they *may cause premature wear* to the moving parts and the oil seals. **After this initial change, the oil can then be changed every three months or 300 hours of operation thereafter.**

Please note: If the pump works in conditions with high humidity and with sharp temperature changes, it is possible that condensation will appear inside the crankcase, which mixing with the oil can change its properties. This is easy to see because the oil changes to a white, milky color.

If the pump does not have excessive water leaking from the packings, and the oil becomes milky, the oil has to be changed more frequently. The percentage of water in the oil must not exceed 20%.

Use Oil per the following chart:

BRAND	TYPE
<b>GENERAL PUMP</b>	<b>SERIES 220</b>
BP	ENERGOL HLP 220
CASTROL	Hyspin VG220, Magna 220
MOBIL	DTE OIL BB
SHELL	TELLUS C 220
TOTAL	CORTIS 220

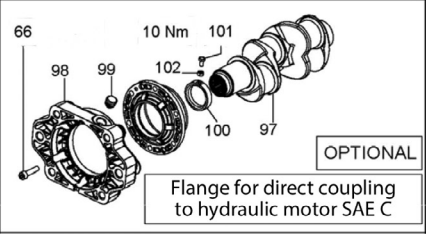
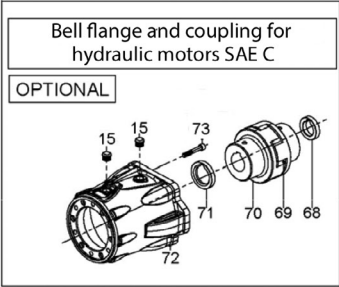
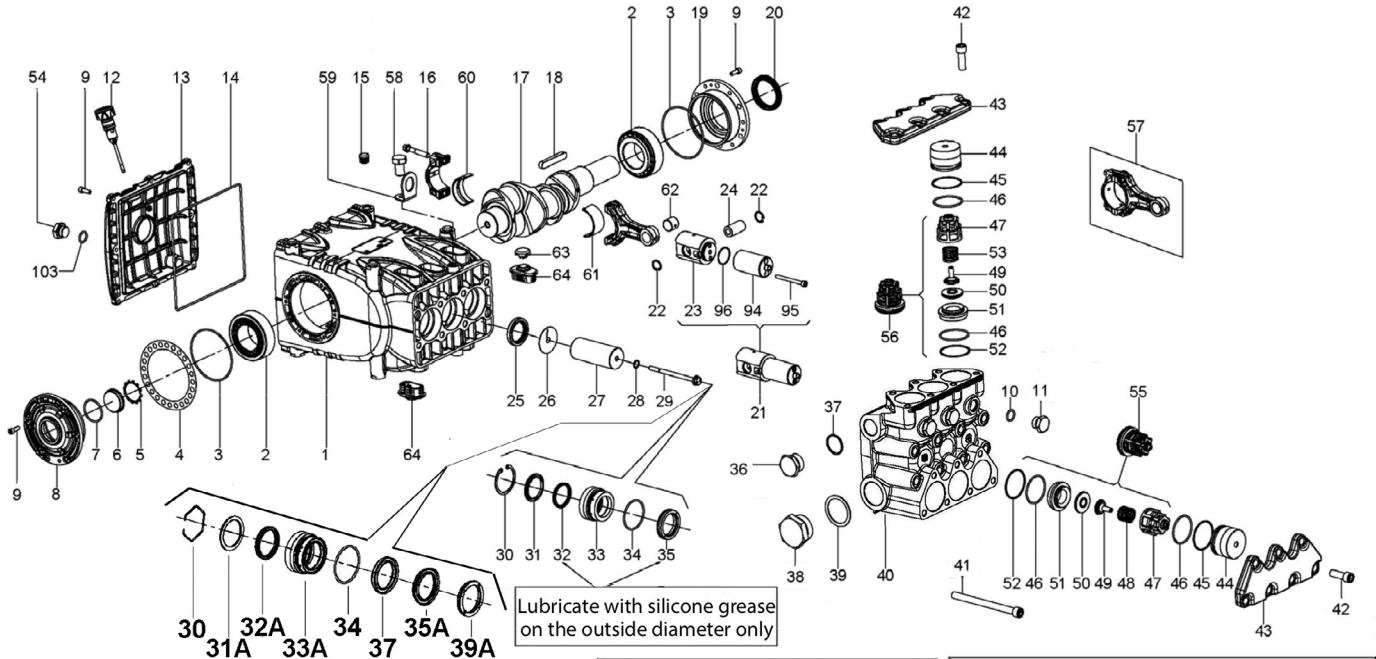

**PARTS LIST**

ITEM	PART NO.	DESCRIPTION	QTY	ITEM	PART NO.	DESCRIPTION	QTY	ITEM	PART NO.	DESCRIPTION	QTY
1.	71010022	Crankcase	1	31A.	F7128270	Ring Seal, Ø 40	3	59.	71223074	Bracket	1
2.	91859000	Bearing, Tapered Roller	2	32.	90245000	Seal, LP, 40 mm	3	60.	90924300	Babbitt, Back	3
3.	90391800	O-ring	2	32A.	F90282800	Seal, LP, 40 mm	3		90924400	Babbitt, Back, +0.25	3
4.	71220081	Shim, 0.1 mm	1	33.	71216670	Retainer, Intermediate, 40 mm	3		90924500	Babbitt, Back, +0.50	3
	71220381	Shim, 0.25 mm	1	33A.	F71215570	Retainer, Intermediate, 40 mm	3	61.	90924000	Babbitt, Front	3
5.	90075600	Retainer	1	34.	90389150	O-ring	3		90924100	Babbitt, Front, +0.25	3
6.	70211801	Oil Level Indicator	1	35.	90246000	Seal, HP, 40 mm	3		90924200	Babbitt, Front, +0.50	3
7.	90387700	O-ring	1	35A.	F90283200	Seal, HP, 40 mm	3	62.	90911000	Bushing, Con-rod	3
8.	71150122	Side Cover, Sight Glass	1	36.	638295	Plug, 1" NPT, SS, OPTIONAL	1	63.	71225951	Plug, Cover, Crankcase	3
9.	99186700	Screw, M6 x 18	20	37.	F90283800	Ring, Restop, Ø40x55x8	3	64.	71225851	Plug, Crankcase	6
10.	701115	O-ring	4	38.	638298	Plug, 1-1/2" NPT, SS, OPTIONAL	1	66.	99309800	Screw, M8 x 35	6
11.	98218300	Plug, 1/2"G Nickel-plated	4	39	93199000	Seal Washer	1	68.	10074570	Spacer, Ø 31.75 x 10.50	1
12.	98212000	Oil Dipstick	1	39A.	F71100351	Ring, Front, Ø 40	1	69.	10074947	Flex Coupler, Ø 55	1
13.	71160022	Crankcase Cover, Rear	1	40.	71124641	Manifold, Nickel-plated, 40 mm, NPT	1	70.	10742801	Flex Coupler, Ø 40 x 31.75	1
14.	90400000	O-ring	1	41.	99448000	Screw, M12 x 150	8	71.	10074670	Spacer, 40 x 10	1
15.	98206000	Rubber Plug	7	42.	99429500	Screw, M12 x 35	14	72.	10075020	Hydraulic Bell Flange, SAE C	1
16.	99313800	Screw	6	43.	71210136	Valve Cover	2	73.	99314600	Screw, M8x50	6
17.	71020035	Crankshaft	1	44.	71211170	Plug	6	94.	71050866	Plunger Guide	3
18.	91500000	Key	1	45.	90525000	Anti-extrusion Ring	6	95.	99199400	Screw, M6 x 65	3
19.	71150022	Crankcase Cover, Open	1	46.	90388950	O-ring	12	96.	90352800	O-ring Ø 29 x 1.5	3
20.	90170000	Crankshaft Oil Seal	1	47.	36204505	Valve Guide	6	97.	71020835	Crankshaft, Ø 50, SAE C	1
21.	71606601	Plunger Guide, Complete	1	48.	94754000	Spring, Outlet	3	98.	10085422	Hydraulic Flange, SAE C	1
22.	90060600	Circlip	6	49.	36208651	Valve Guide	6	99.	90206500	Plug, Plastic	1
23.	71050015	Plunger Guide	3	50.	36208502	Valve, Spherical	6	100.	71228971	Ring, Ø 40	1
24.	97743000	Wrist Pin	3	51.	36204156	Valve Seat	6	101.	70227034	Screw, M6 x 12	1
25.	90167800	Plunger Rod Oil Seal	3	52.	90524000	Anti-extrusion Ring	6	102.	99202500	Nut, M6 x 5	1
26.	96714000	Flinger Washer	3	53.	94755000	Spring, Ø 25.2x26	3	103.	90384100	O-ring, Ø17.13 x 2.62	1
27.	71040509	Plunger, 40 mm	3	54.	98218700	Plug, G1/2" x 13	1		HT150RCK	Rail Conversion Kit	1
28.	90367150	O-ring	3	55.	36716601	Valve Assy., Inlet	3		200082	Bolts, M12-1.75 x 25 mm	4
29.	71219566	Plunger Bolt	3	56.	36716701	Valve Assy., Outlet	3		200083	Lock Washer, M16	4
30.	90079700	Circlip	3	57.	71030701	Connecting Rod	3				
31.	71218970	Ring Seal, Ø 40	3	58.	99512000	Screw, M12x25	1				

**REPAIR KITS**

KIT NO.	K2012	K2013	K2033	K2034	F2020	K2035
ITEM NO'S INCLUDED IN KIT	46, 47, 48, 49, 50, 51, 52, (55)	46, 47, 49, 50, 51, 52, 53 (56)	32, 35	30, 31, 32, 33, 34, 35	32A, 34, 35A, 37	30, 31A, 32A, 33A, 34, 35A, 37, 39
NUMBER OF ASSY'S IN KIT	3	3	3	1	3	3 kits needed for pump
NO. OF CYLINDERS KIT SERVICES	3	3	3	1	3	

**TORQUE SPECS\***

Position	Ft.-Lbs.	Nm.
9	7.4	10
11	29.5	40
16	22	30
29**	14.7	20
36	110.6	150
38	110.6	150
41	59.0	80
42	88.5	120
54	29.5	40
58	29.5	40
66	29.5	40
73	29.5	40
101	7.4	10

\*Decrease torque by 20% if threads are lubricated.

\*\*Use Loctite 542.

**DIMENSIONS**

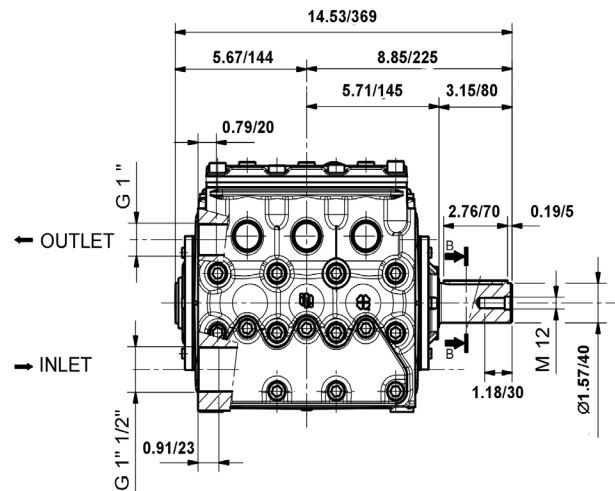
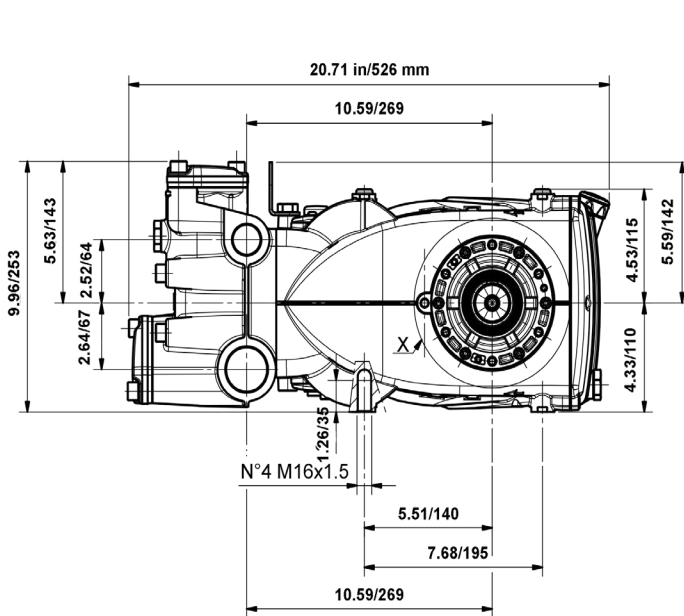

**WARNING: High Pressure Systems require a primary pressure regulating device (i.e. regulator, unloader) and a secondary pressure relief device (i.e. pop-off valve, relief valve). Failure to install such relief devices properly could result in personal injury or damage to pump or property. GP does not assume any liability or responsibility for the operation of the user's high pressure system.**

**WARNING:** This product can expose you to chemicals including lead, which is known to the state of California to cause cancer and birth defects or other reproductive harm. For more information, go to [www.P65Warnings.ca.gov](http://www.P65Warnings.ca.gov)