

Owner's Manual

- *Installation*
- *Use*
- *Maintenance*

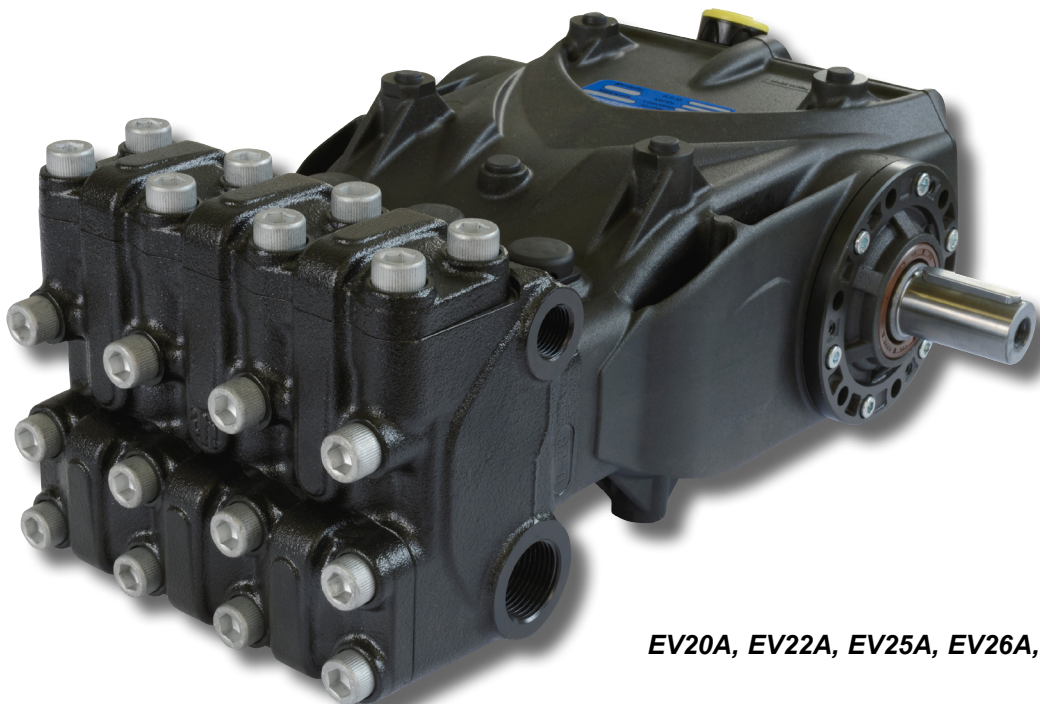

EV20A, EV22A, EV25A, EV26A, EV28A

INDEX

1.	INTRODUCTION	Page 3
2.	DESCRIPTION OF SYMBOLS	Page 3
3.	SAFETY	Page 4
	3.1 General safety instructions	Page 4
	3.2 High pressure unit safety requirements	Page 4
	3.3 Safety during operation	Page 4
	3.4 General procedures for using nozzles	Page 4
	3.5 Safety during unit maintenance	Page 5
4.	PUMP IDENTIFICATION	Page 5
5.	TECHNICAL FEATURES	Page 6
6.	DIMENSIONS AND WEIGHT	Page 6
7.	OPERATING INSTRUCTIONS	Page 7
	7.1 Water temperature	Page 7
	7.2 Maximum flow and pressure rates	Page 7
	7.3 Minimum RPM	Page 7
	7.4 Vibration	Page 7
	7.5 Recommended lubricant types and Manufacturers	Page 7
8.	PORTS AND CONNECTIONS	Page 9
9.	PUMP INSTALLATION	Page 9
	9.1 Installation	Page 9
	9.2 Direction of rotation	Page 10
	9.3 Version change and reducer positioning	Page 10
	9.4 Hydraulic connections	Page 11
	9.5 Pump power supply	Page 11
	9.6 Suction line	Page 11
	9.7 Filtration	Page 12
	9.8 Outlet line	Page 13
	9.9 Internal diameter of hose	Page 13
	9.10 V-belt transmission	Page 14
	9.11 Transmission of Power	Page 14
	9.12 Definition of Static Pull to Apply on Belts	Page 16
10.	START UP AND OPERATION	Page 17
	10.1 Preliminary inspections	Page 17
	10.2 Starting up	Page 17
11.	PREVENTATIVE MAINTENANCE	Page 18
12.	PUMP STORAGE	Page 18
	12.1 Longterm Inactivity	Page 18
	12.2 Filling the pump with anti-corrosion emulsion or anti-freeze	Page 18
13.	PRECAUTIONS AGAINST FREEZING	Page 18
14.	WARRANTY TERMS	Page 19
15.	TROUBLESHOOTING	Page 19
16.	EXPLODED VIEWS AND PARTS	Page 21
17.	MAINTENANCE LOG	Page 23

1. INTRODUCTION

This manual describes the use and maintenance instructions of the EV pump, and should be carefully read and understood before using the pump.

Correct use and adequate maintenance will guarantee the pumps trouble-free operation for a long time. General Pump declines any responsibility for damage caused by misuse or the non-observance of the instructions indicated in this manual.

Upon receiving the pump, check that it is complete and in perfect condition. Should anything be found out of order, please contact us before installing and starting the pump.

2. SYMBOL DESCRIPTIONS



Warning
Potential Danger

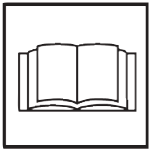

Read carefully and understand
the manual before operating
the pump



Danger
High Voltage



Danger
Wear protective mask



Danger
Wear goggles



Danger
Wear protective gloves



Danger
Wear protective boots

3. SAFETY

3.1 General Safety Indications

Improper use of pumps and high pressure systems, and the non-compliance with installation and maintenance instructions may cause severe injury to people and/or damage to property. Anyone assembling or using high pressure systems must possess the necessary competence to do so, should be aware of the characteristics of the components assembled/used, and must take all precautions necessary to ensure maximum safety in any operating condition. In the interest of safety, both for the Installer and the Operator, no reasonably applicable should be omitted.

3.2 High pressure unit safety requirements

1. The pressure line must always be equipped with a safety valve.
2. High pressure system components, in particular for those units working outside, must be adequately protected against rain, frost and heat.
3. The electrical control system must be adequately protected from water spray, and must comply with the specific regulations in force.
4. High pressure hoses must be properly sized for maximum operating pressure of the system and always and only used within the operating pressure range specified by the hose manufacturer. The same rules should be observed for all other auxiliary systems affected by high pressure.
5. The ends of high pressure hoses must be sheathed and secured to a solid structure to prevent dangerous whiplash in case of bursting or broken connections.
6. Appropriate safety guards must be provided for the pump transmission systems (couplings, pulleys and belts, auxiliary drives).



3.3 Safety During Operation

The working area of a high pressure system must be clearly marked. Access must be prohibited to unauthorized personnel and, wherever possible, the area should be restricted or fenced. The personnel authorized to access this area should first be trained, and informed about the risks that may arise from failures or malfunctions of the high pressure unit.

Before starting the unit, the operator must check:

1. That the high pressure system is properly powered (see paragraph 9.5).
2. That pump intake filters are perfectly clean; we advise the use of a device that indicates the filters clogging level.
3. Electrical parts are adequately protected and in perfect condition.
4. The high pressure hoses do not show apparent signs of abrasion, and that fittings are in perfect shape.
5. In relation to the application, use and environmental conditions, during the operation the outer surfaces of the pump may reach high temperatures. Therefore we recommend to take precautions to avoid contact with hot parts.

Any fault or reasonable doubt that may arise before or during operation should be promptly reported and verified by competent personnel. In these cases, pressure should immediately be released and the high pressure system stopped.



3.4 General Procedures For Using Nozzles

1. The Operator must always place their safety and security first, as well as that of others that may be directly affected by their actions, or any other assessments or interests. The operator's work must be dictated by common sense and responsibility.
2. The Operator must always wear a helmet with a protective visor, waterproof clothing, and appropriate boots capable of guaranteeing grip on wet pavement.

Note: appropriate clothing will effectively protect against water spray, but it may not offer adequate protection against the direct impact of water jets or sprays from a close distance. Some circumstances may require further protection.

3. It is generally best to organize personnel into teams of at least two people capable of giving mutual and immediate assistance in case of necessity and of taking turns during long and demanding operation.
4. Access to the work area that is within the water jets' range must be absolutely prohibited to and free from objects that, inadvertently under a pressure jet, can be damaged and or create dangerous situations.
5. The water jet must only and always be directed in the direction of the work area, including during testing or preliminary tests or checks..
6. The Operator must always pay attention to the trajectory of the debris removed by the water jet. If necessary, suitable guards must be provided by the Operator to protect anything that may be accidentally exposed.
7. The Operator should not be distracted for any reason during operation. Workers needing to access the operating area must wait for the Operator to stop work, and then immediately make their presence known.
8. For safety reasons, it is important that each member of the team is fully aware of the intentions and actions of other team members in order to avoid dangerous misunderstandings.
9. The high pressure system must not be started up and run under pressure without all team members in position and without the Operator having already directed their lance toward the work area.

3.5 Safety During System Maintenance

1. The pressure system maintenance must be carried out in the time intervals set by the manufacturer who is responsible for the whole group according to law.
2. Maintenance should always be carried out by trained and authorized personnel.
3. Assembly and disassembly of the pump and its various components must be performed exclusively by authorized personnel, using appropriate equipment in order to avoid damage to components and connections.
4. Always use original spare parts to ensure total reliability and safety.

4. PUMP IDENTIFICATION

Each pump has a specific serial number (1, fig. 1) and a pump label (2, fig. 1) which contains:

- Pump model and version
- Maximum RPM
- Power Hp-kW
- Pressure - P.S.I.
- Flow Rate - GPM



Pump model, version and serial number must always be specified when ordering spare parts.

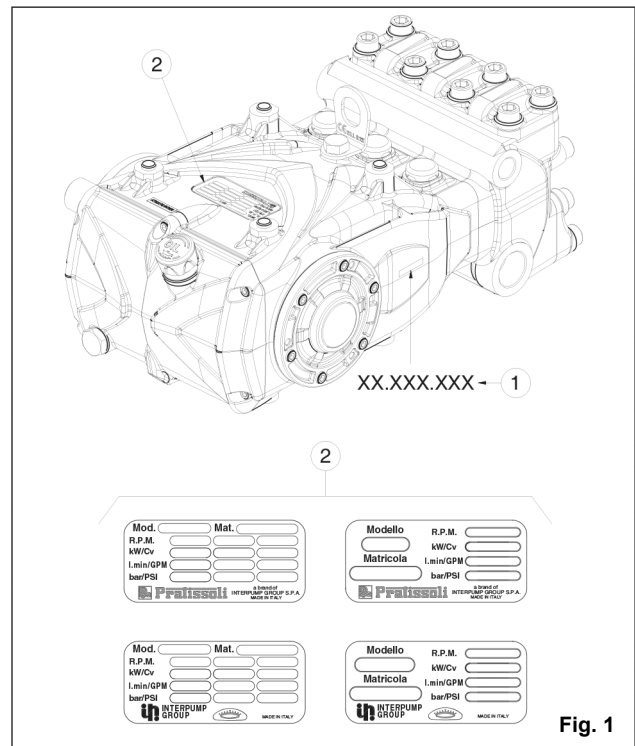

Fig. 1

5. TECHNICAL FEATURES

MODEL	RPM	FLOW RATE		PRESSURE		POWER	
		l/min	GPM	PSI	Bar	Hp	kW
EV20A	1450	48	12.68	3770	260	33	25
	1750	58	15.32	3770	260	40	30
EV22A	1450	58	15.32	3000	207	32	24
	1750	70	18.49	3000	207	38	28
EV25A	1450	75	19.82	3000	207	41	31
	1750	90	23.78	3000	207	49	37
EV26A	1450	81	21.40	2610	180	38	28
	1750	98	25.89	2610	180	46	34
EV28A	1450	94	24.83	2000	138	34	25

6. DIMENSIONS AND WEIGHT

For the pumps dimensions and weight, refer to Fig. 2.

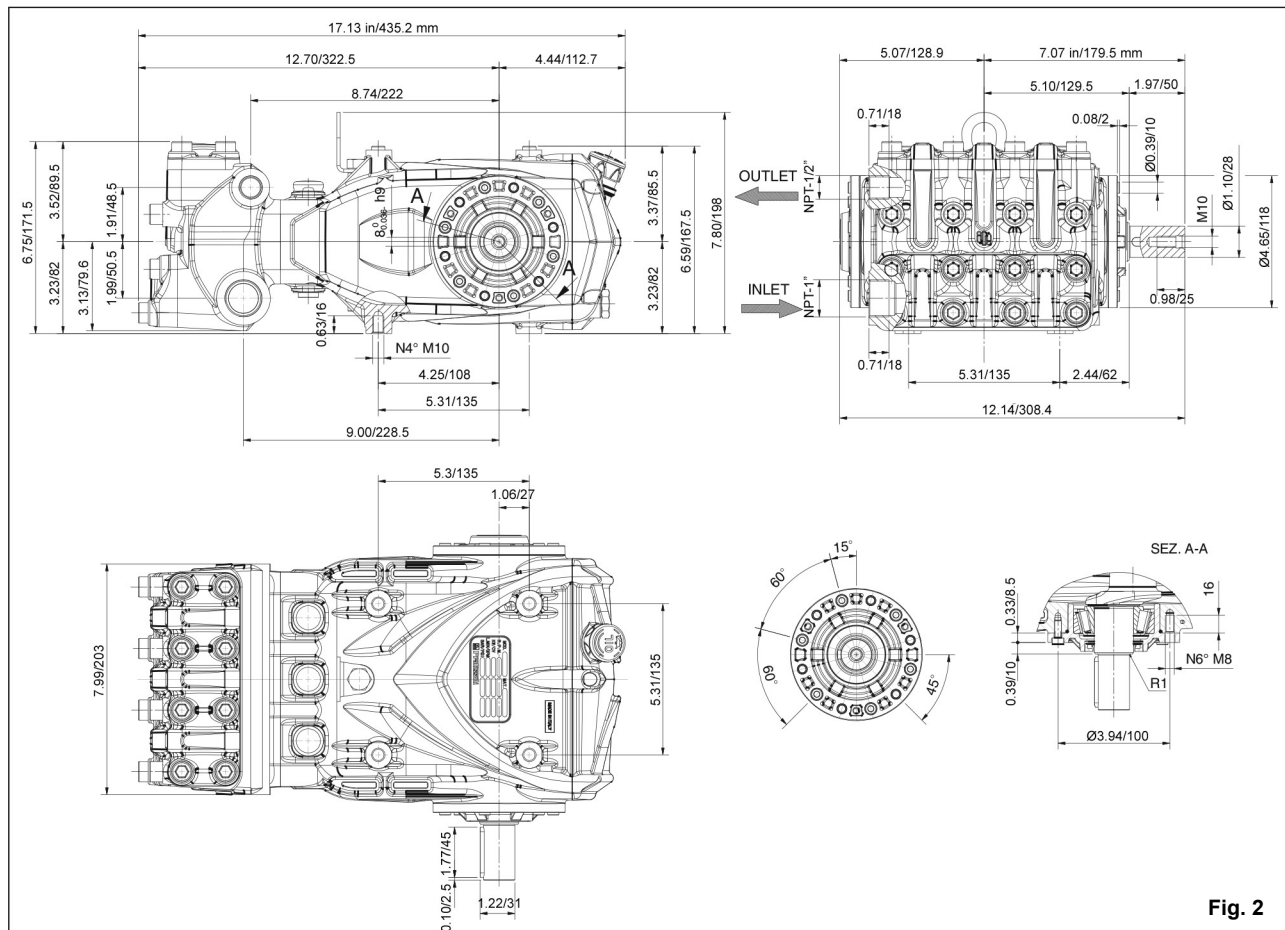

Weight: 68.34 Lbs./29.5 Kg.

Ref 310209 Rev. E
06-23

7. INFORMATION ABOUT PUMP USE



The EV pumps is designed to operate in environments with atmospheres that are not potentially explosive, and with filtered water (see par. 9.7) at a max 104° F (40° C).

Other fluids may be used only upon the approval of The Customer Service Department.

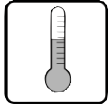

7.1 Water Temperature

The max water temperature is 104° F (40° C). However, it is possible to use the pump at temperatures of up to 140° F (60° C) for short periods of time. In this case we advise consulting the Customer Service Department.

7.2 Max Pressure and Flow Rate

The performance values indicated in the catalog refer to the maximum performance of the pump. Regardless of the power used, pressure and maximum RPM values indicated on the plate may not be exceeded unless expressly authorized by the **Customer Service Department**.

7.3 Minimum Operating Speed

The minimum speed of the crankshaft for these types of pumps is 100 RPM. Any lower RPM value different must authorized by the **Customer Service Department**.

7.4 Vibration

The detection of vibrations must be carried out with the pump set up in the plant and at the performance desired by the customer. Values must me in accordance with regulations

7.5 Recommended Lubricant Oil Types & Manufacturers

The pump is delivered with lubricant oil compliant with room temperatures ranging between 32° and 89.6° F (0° C and 30° C). Some recommended lubricant types are indicated in the table below; these lubricants are treated with additives in order to increase corrosion protection and resistance to fatigue. As an alternative, Automotive SAE 85W-90 gearing lubricants may also be used.

BRAND	TYPE
GENERAL PUMP	SERIES 220
ARAL	Aral Degol BG 220
BP	ENERGOL HLP 220
CASTROL	Hyspin VG 220, Magna 220
ELF	POLYTELIS 220
ESSO	NUTO 220
FINA	Cirkan 220
FUCHS	RENOLIN 220
MOBIL	DTE OIL BB
SHELL	TELLUS C 220
TEXACO	RANDO HD 220
TOTAL	CORTIS 220

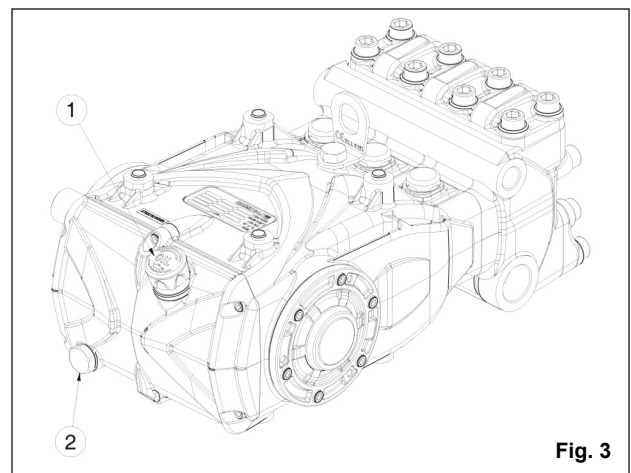

Fig. 3



In any case the oil must be changed at least once a year, as it is a degraded by oxidation.

Check the oil level by using the oil level dipstick (1, fig. 3). Refill if necessary to top off level. Correct oil level inspection is done with the pump at room temperature; oil is changed with the pump at working temperature, by removing the rear plug (2, fig. 3). Checking and changing oil is to be carried out as indicated in Chapter 11. The amount required is 64.25 oz (1.9 liters)

For room temperatures other than between 32° F - 86° F, follow the instructions in the following diagram, considering the oil must have a minimum viscosity of 180 cSt.

VISCOSITY/ROOM TEMPERATURE DIAGRAM

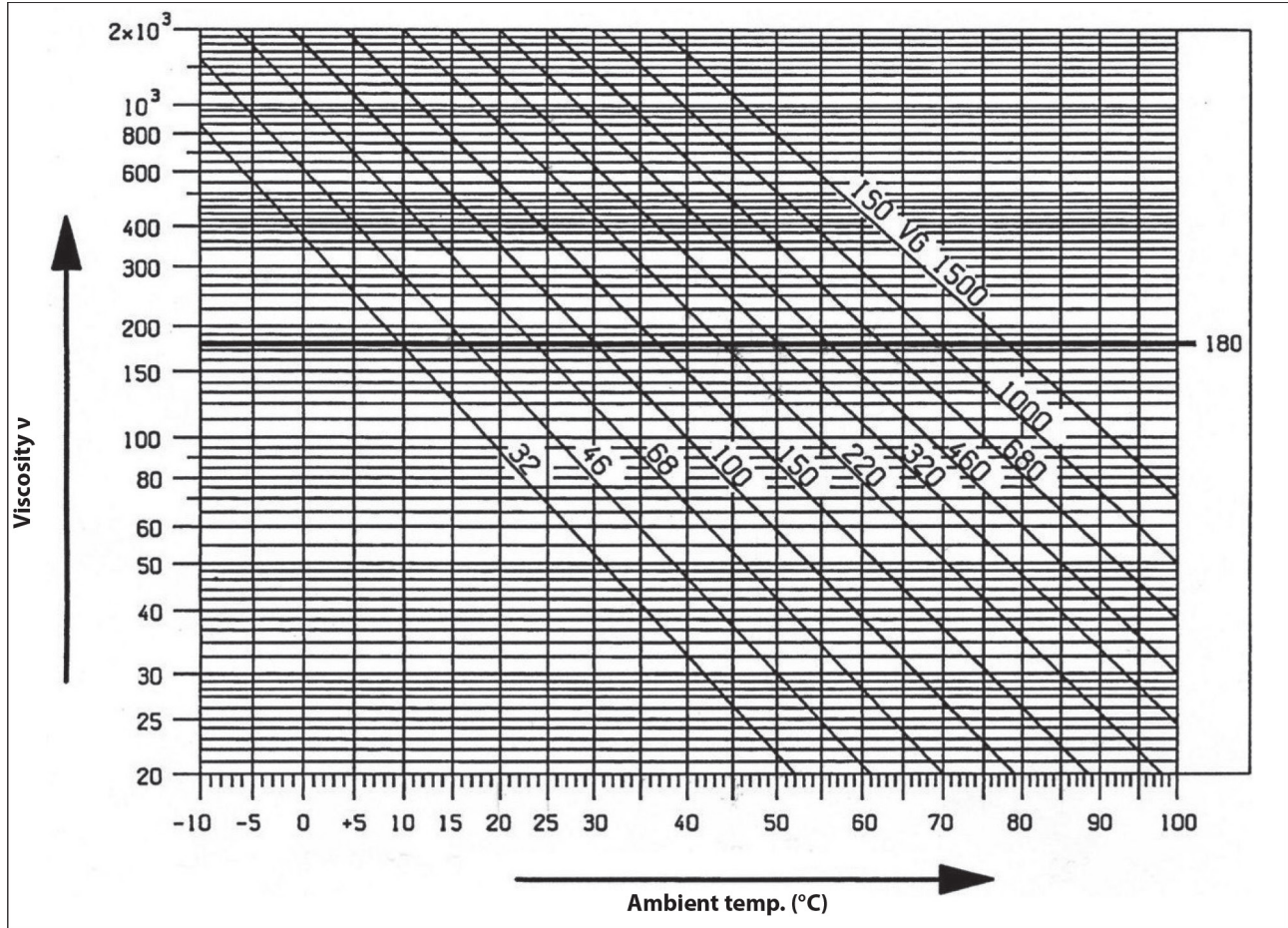

Exhausted oil must be collected in an appropriate container and disposed of in appropriate locations. In absolutely no case may it be dispersed into the environment.

8. PORTS AND CONNECTIONS

EV Series pumps are equipped with (see fig. 4):

1. 2 inlet ports "IN", 1" NPT.

The line can be connected to either of the two inlet ports; the ones not being used must be hermetically sealed.

2. 2 outlet ports "OUT", 1/2" NPT.

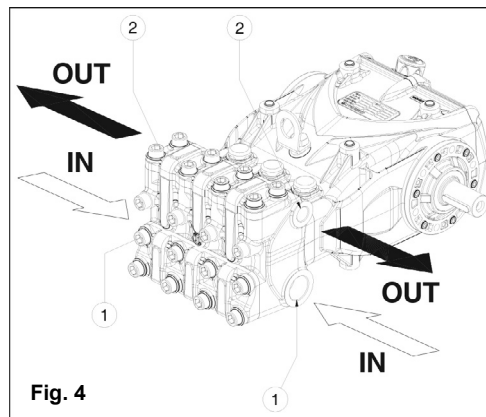

9. PUMP INSTALLATION

9.1 Installation

The pump must be installed in a horizontal position using the M10 threaded support feet. Tighten the screws with a torque of 10.12 Ft-lbs (45 Nm).

The base must be perfectly flat and rigid enough as not to allow bending or misalignment on the pump coupling and axis/transmission due to torque transmitted during operation.

The unit cannot be rigidly fixed to the floor but must use vibration dampers.

A lifting bracket is mounted on the pump crankcase for easy installation, as per figure below.





The bracket is sized for lifting the pump only. Therefore it must never be used for any additional loads.



Replace the oil filling hole closing service plug (red) positioned on the rear casing cover with the plug with oil dipstick. Check the correct quantity.

The dipstick must always be reachable, even when the unit is assembled.



The pump's shaft (PTO) must not be rigidly connected to the motor unit.

The following transmission types are suggested:

- Hydraulics by flange, for proper application contact Customer Service Department
- Flexible joint
- Cardan Joint (please respect the maximum working angles indicated by the manufacturer)
- Belts; for correct application, please contact the Customer Service Department.

9.2 Direction of rotation

The PTO rotation is indicated by an arrow located on the reduction gear cover. From a position facing the pump head, the rotation direction will be as in fig. 5.

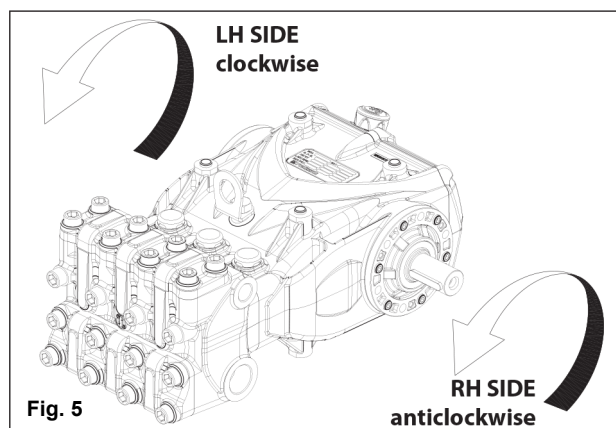

9.3 Version Change and Reducer Positioning

A right version pump is defined when: observing the pump from the head side, the PTO shank of the pump shaft is on the right side.

A left version pump is defined when: observing the pump from the head side, the PTO shank is on the left side.

Note: The version shown in Fig. 5 is right.



The version may be changed only by trained and authorized personnel by carefully following the instructions below.

1. Separate the hydraulic part from the mechanical part as indicated in Chapter 2 in points 2.2.1 and 2.2.2 of the Repair Manual.
2. Turn the mechanical part 180° and reposition the rear casing cover in such a way that the oil dipstick is turned upward. Reposition the lifting bracket and relative hole closing plugs in the upper part of the casing. Invert the two inspection covers, ensuring that the open one is positioned lower. Finally, properly reposition the specification label in its housing on the casing.



Make sure that the lower casing draining holes in correspondence with the pistons are open and not closed from the plastic plugs provided for the previous version.

3. Reassemble the hydraulic part to the mechanical part as indicated in Chapter 2 in points 2.2.1, 2.2.4 and 2.2.5 of the Repair Manual.

9.4 Hydraulic Connections

In order to isolate the system from the vibrations produced by the pump, we advise to build the first section of the duct near the pump (both for intake and delivery) with flexible hose. The consistency of the intake section must allow to avoid deformation caused by the depressurization produced by the pump.

9.5 Pump Supply

A positive head of at least 0.66 ft. (0.20 meters) is required for the best volumetric efficiency.



For negative prevalence contact Customer Service Department.

9.6 Suction Line

For the pump's correct operation, the suction line must have the following characteristics:

1. Minimum internal diameter as indicated in the diagram in paragraph 9.9, and in any case equal or greater than the pump head's value.



Along the duct, avoid localized diameter reductions that may cause pressure drops with subsequent cavitation. Absolutely avoid 90° elbows, connections with other hoses, bottlenecks, counter-slopes, upside down "U" shaped curves, "T" connections.

2. With a layout that is set in such a way to prevent cavitation.
3. It should be perfectly airtight, and built in a way that guarantees perfect sealing over time.
4. Avoid pump emptying when stopping (even partial emptying).
5. Do not use hydraulic fittings, 3 or 4 way fittings, adapters, swivel joints, etc., since they may hinder the pump's performance.
6. Do not install Venturi tubes or injectors for detergent intake.
7. Avoid the use of base valves or any other type of one-way valves.
8. Do not connect the by-pass line from the valve directly to the pump suction line.
9. Provide appropriate baffle plates inside the tank in order to avoid water flows coming from both the by-pass and feeding lines which may create turbulence near the tank's outlet port.
10. Make sure that the suction line is perfectly clean inside before connecting it to the pump.
11. The pressure gauge for checking booster pressure must be installed near the plunger pump's inlet port, and always downstream from the filters.

9.7 Filtering

On the suction line, install one filters as indicated in fig. 6 and fig. 6a.

With the manual adjustment valve:

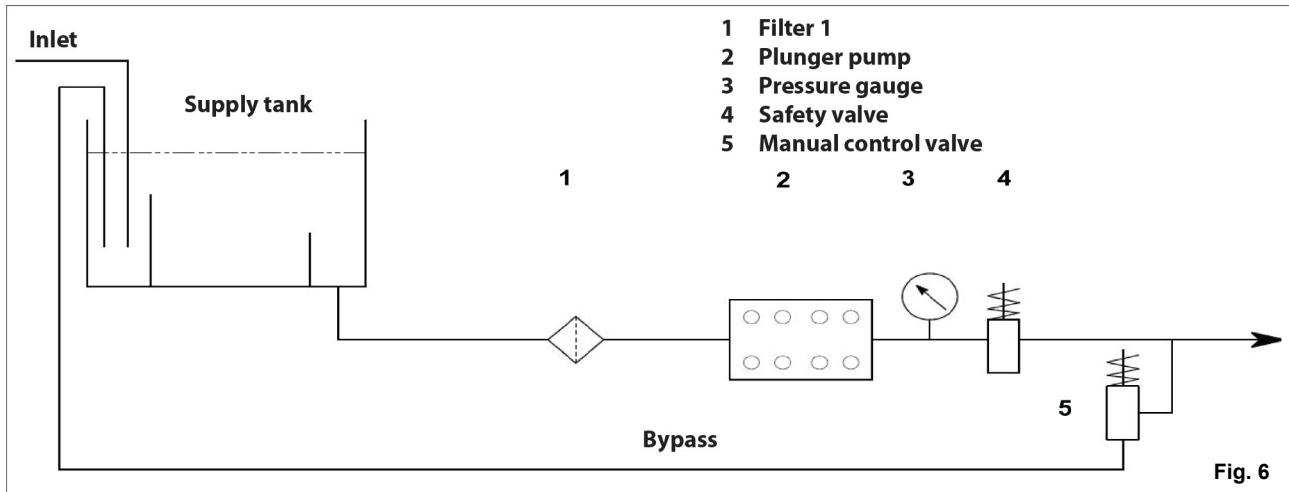

With the pneumatic adjustment valve:

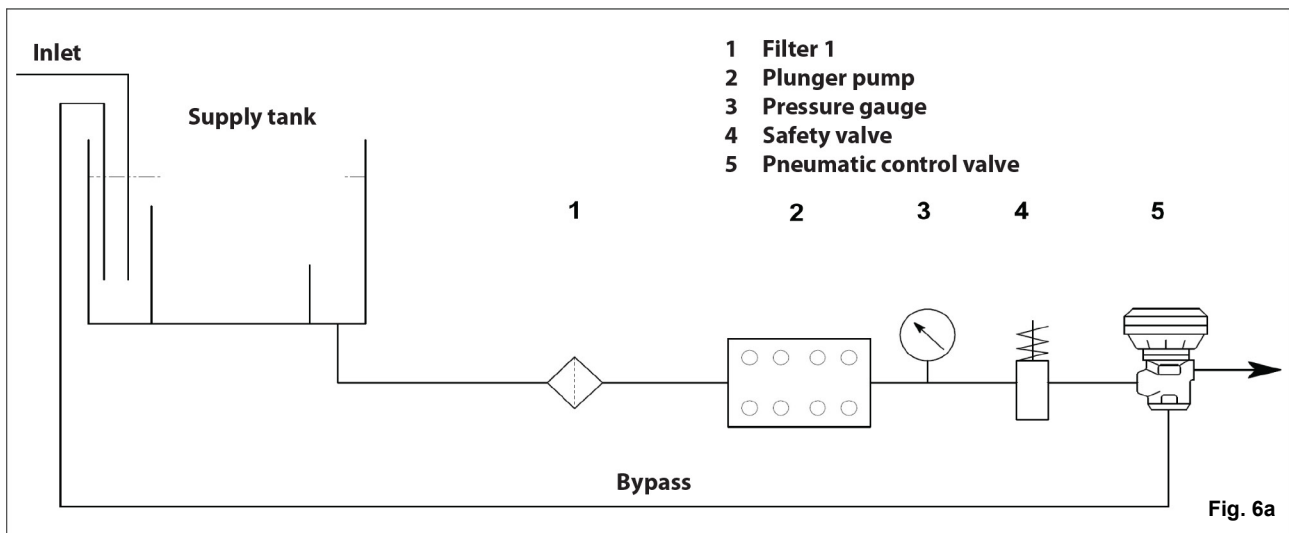

The filter must be installed as close as possible to the pump, should allow easy inspection and have the following characteristics:

1. Minimum capacity 3 times greater than the pump's rated flow value.
2. Filter port diameters must not be smaller than the pump inlet ports.
3. Filtration degree ranging between 200 and 360 μm .



In order to guarantee correct pump operation, it is important to plan periodical cleaning of the filter depending on actual pump usage, water quality and actual clogging conditions.

9.8 Outlet Line

To obtain a correct delivery line, please comply with the following installation instructions:

1. The internal diameter of the hose must allow to guarantee correct fluid speed; see digram in paragraph 9.9
2. The first section of the hose connected to the pump must be flexible in order to isolate pump vibrations from the rest of the system.
3. Use high pressure hoses and fittings that guarantee wide safety margins in any working condition.
4. Install a safety valve on the delivery line.
5. Use pressure switches suitable for the pulsating loads typical of plunger pumps.
6. In the design phase, take into proper account the pressure drop along the line, since this causes a reduction in usage pressure with respect to the value measured at the pump.
7. If the pump pulsations are harmful for particular applications, install an appropriately sized pulsation dampener on the outlet line.

9.9 Internal Diameter of the Hose Line

To determine the internal diameter of the hose, please refer to the following diagram.

Suction Hose

With a flow rate of ~25.90 GPM (98 l/mn) and water speed of 0.5 m/sec. the diagram line that connects the two scales intersects the central scale, indicating the diameters, at a value of ~ 2.52 inch (64 mm).

Delivery Hose

With a flow rate of ~25.90 GPM (98 l/mn) and water speed of 5 m/sec. The diagram line that connects the two scales intersects the central scale, indicating the diameters at a value of ~ 0.79 inch (20 mm).

Optimal speed to be obtained with the booster pump:

- Suction: ≤ 0.5 m/sec.
- Delivery: ≤ 5 m/sec.

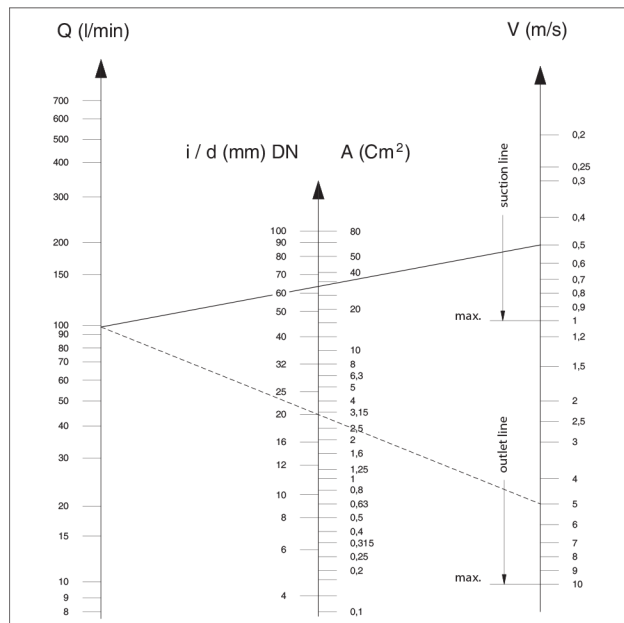

The diagram does not take into account the hose and valve resistance, the pressure drop due to the pipe length, the viscosity and the temperature of the pumped fluid. If necessary, contact our Customer Service Department.

9.10 V-belt Transmission

The pump can be controlled by a V-belt system. For these pump models, we recommend use of 3 XPB belts (16.5x13 serrated). Use an XPC profile only for long durations. Both the characteristics and transmissible power of each belt can be verified in the diagram in Fig. 7, in relation to the number of rpm normally declared by the manufacturer. Minimum duct pulley diameter (on pump shaft): ≥ 6.3 in (160 mm). The radial load on the shaft must not exceed 3319 ft. lbs. 4500 N (value necessary for Layout definition). The transmission is considered adequate if the load is applied to a maximum distance $a = 1.97$ in. (50 mm) from the shaft shoulder (P.T.O) as shown in Fig. 10.



For dimensions differing from those specified above, contact our Customer Service Department.

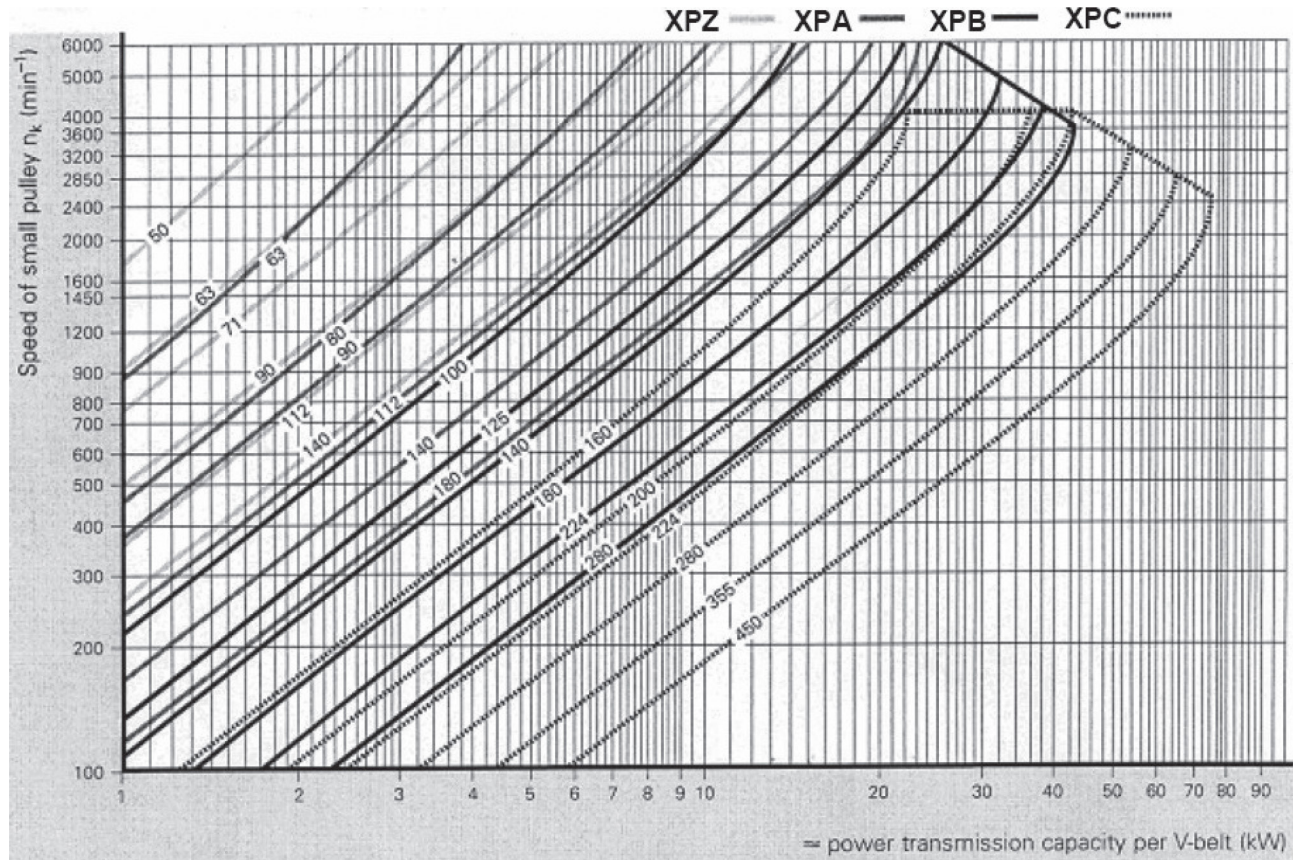

Fig. 7

9.11 Transmission of power

To prevent irregular radial loads on the shaft and the relative bearing, follow these directions:

- A) Use pulleys with V-belts with the size of the groove required/recommended by the manufacturer of belt used. In the absence of directions, follow Fig. 8 and the table in Fig. 9.

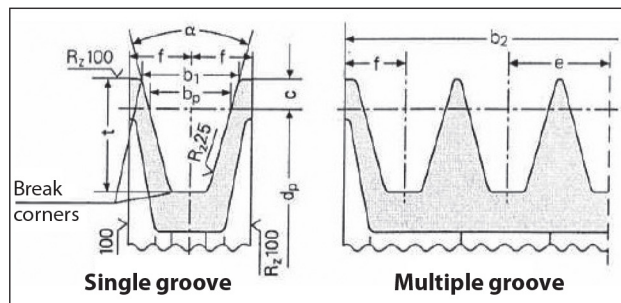

Fig. 8

Dimensions (in mm)

Belt section as per DIN 7753 part 1 and B.S. 3790		DIN symbol symbol B.S./ISO	XPB/SPB SPB	XPC/SPC SPC
Belt section as per DIN 2215 and B.S. 3790		DIN symbol symbol B.S./ISO	17 B	22 C
Pitch width		b_w	14.0	19.0
Increased grooving width $b_1 \approx$			$\alpha = 34^\circ$	18.9
			$\alpha = 38^\circ$	19.5
		c	8.0	12.0
Distance between grooving		and	23 ± 0.4	31 ± 0.5
		f	14.5 ± 0.8	20.0 ± 1.0
Increased grooving depth		t_{min}	22.5	31.5
α	34°	by primitive diameter	d_w	from 140 to 190
	38°	narrow-section V-belts DIN 7753 part 1		> 190
α	34°	by primitive diameter	d_w	from 112 to 190
	38°	classic section V-belts DIN 2215		> 190
Tolerance for $\alpha = 34^\circ-38^\circ$				$\pm 1^\circ$
Pulleys for b_2 by grooving number z $b_2 = (z-1) e + 2 f$			1	29
			2	52
			3	75
			4	98
			5	121
			6	144
			7	167
			8	190
			9	213
			10	236
			11	259
			12	282
Minimum pulley diameter must be respected. Do not use laminated V-belts.				

Fig. 9

B) Use high performance belts – for example XPB instead of SPB – as a lower quantity of belts for the same transmitted power may be necessary and a consequent shorter resulting distance compared to the shaft shoulder (P.T.O) “a” of Fig. 10.

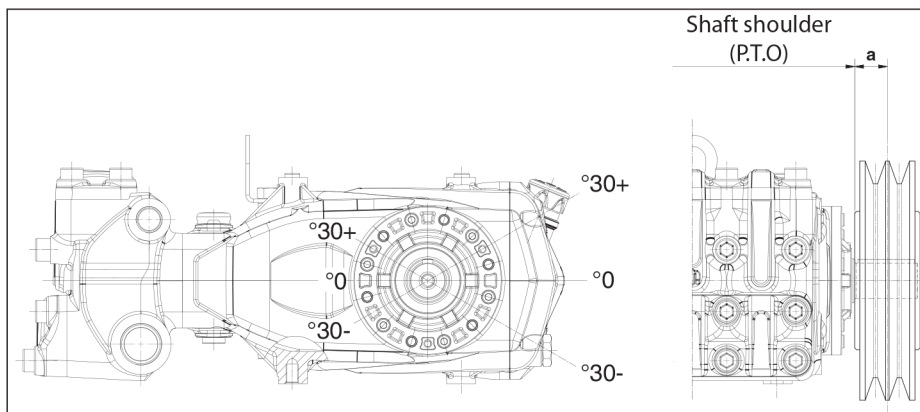

Fig. 10

- C) Pull the belts according to manufacturer instructions. Excessive pulling can cause reduced bearing life and wear out the pulley prematurely. Pulling depends on different variables as indicated in par. 9.12.
- D) Belt length has a natural tolerance $\geq \pm 0.75\%$. For this reason, the 3 belts must be purchased as a pair.
- E) Follow the direction of the belt pull as shown in Fig. 10 for other needs, contact our Customer Service Department.
- F) Take care of the alignment of the driving pulley and driven pulley grooves.

9.12 Definition of static pull to apply on belts

Static pull depends on:

- a) The wheelbase between the two pulleys (belt length).
- b) The load due to static pull of the belt.
- c) The number of belts.
- d) The winding angle of the smallest pulley.
- e) Average speed.
- f) Etc.

Values of the static pull to be applied can be obtained from the diagram in Fig. 11 for belts with a XPB profile in relation to the wheelbase.

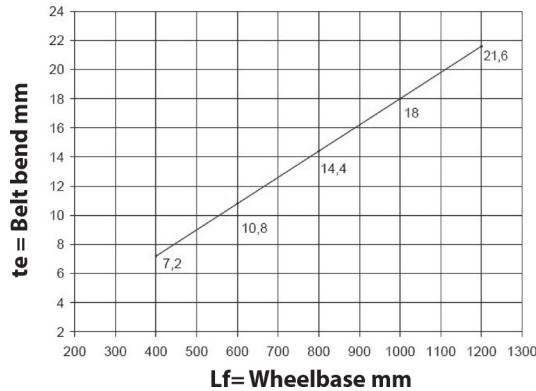
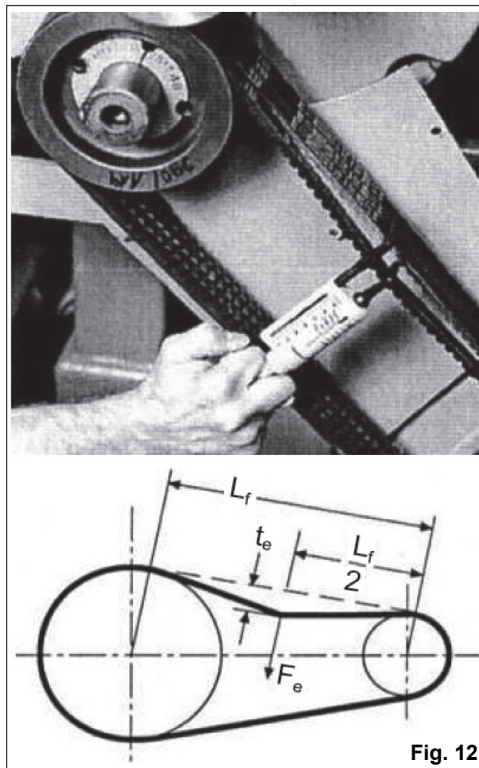

Fig. 11

Conclusion: with a wheelbase of 23.62 in (600 mm) and with a dynamo-meter, loading the belt branch with 16.86 ft. lbs. (75 N) as indicated in Fig. 12, a “te” bend of approximately 0.43 (10.8 mm) is obtained.



Lf = Wheelbase
 te = Belt bend
 Fe = 75 N Dynamometer load

Note: Unless otherwise stated by the supplier of the belts, control of proper pull and its relative re-tensioning should be performed after no less than 30 minutes of motion necessary for the normal adjustment of the belts. Best performance and durability will be achieved with proper tensioning.

Note: In case of necessity or for routine maintenance, never replace a single belt but the complete set.

10. START-UP AND OPERATION

10.1 Preliminary Inspections

Before Start-up Be sure that:



The suction line is connected and up to pressure (see Chapter 9) the pump must never run dry.

1. The suction line must be perfectly airtight.
2. All the On-Off valves between the pump and the feeding source are completely open. The delivery line must discharge freely in order to allow the air in the pump to be ex-pulsed easily, thus facilitating pump priming.
3. All suction/delivery connections and fittings must be correctly tightened.
4. Coupling tolerances on the pump/transmission axis (half-joint misalignment, Cardan joint tilt belt tightening, etc.) must remain within the limits indicated by the transmission Manufacturer.
5. The pump's oil level must be verified using the correct dipsticks (1, fig. 13) and with the oil level indicator (2, fig. 13).

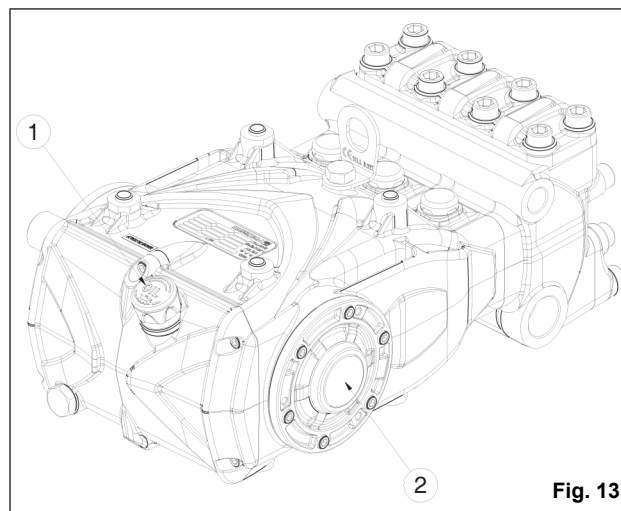

Fig. 13

10.2 Start-up

1. When starting the pump for the first time, check for the correct direction of rotation.
2. Verify correct feeding pressure.
3. The pump must be started off-load.
4. During operation, check that the rotating speed does not exceed the rated value.
5. Before putting the pump under pressure let it run for at least 3 minutes.
6. Before stopping the pump, release the pressure by acting on the adjustment valve or on any discharging device.

11. PREVENTIVE MAINTENANCE

To guarantee pump reliability and efficiency, comply with the maintenance intervals as indicated in the table below.

PREVENTIVE MAINTENANCE	
EVERY 500 HOURS	EVERY 1500 HOURS
Check oil level	Change oil
	Check / Replace:* Valves Valve seats Valve springs Valve guides
	Check / Replace: H.P. packings L.P. packings

* For replacement follow instructions contained in the repair manual.

12. PUMP STORAGE



12.1 Long-term inactivity

If the pump is started for the first time after a long period from the date of shipment, before operation check the oil level, inspect the valves as specified in chapter 10, then follow described start-up procedures.

12.2 Filling the Pump With An Anti-Corrosion Emulsion or Anit-freeze

Method for filling pump with anti-corrosion emulsion or anti-freeze solution using an external diaphragm pump based on the layout shown in par. 9.7 in Fig. 6 and Fig. 6/a:

- In place of the service tank, use a suitable container containing the solution to be pumped.
- Close the filter drainage, if open.
- Make sure that the hoses to be used are clean inside and spread grease on their connections.
- Connect the high pressure outlet pipe to the pump.
- Connect the inlet pipe to the diaphragm pump.
- Connect the inlet pipe between the pump head and the diaphragm pump.
- Fill the service container with solution/emulsion.
- Insert the free ends of the inlet pipes and the high pressure outlet pipe inside the container.
- Switch on the diaphragm pump.
- Pump the emulsion until it exits from the high pressure exhaust pipe.
- Continue pumping for at least another minute.
- Stop the pump and remove the previously connected pipes.
- Clean, grease and plug the connections on the pump head.

The characteristics of the emulsion can be strengthened if necessary by adding, for example, Shell Donax.

13. PRECAUTIONS AGAINST FREEZING



In areas and periods of the year where there is risk of freezing, follow the instructions indicated in Chapter 12 (see paragraph 12.2).



In the presence of ice, do not start the pump for any reason until the circuit has been fully defrosted, otherwise there can be serious damage to the pump.

14. WARRANTY TERMS

The pump is guaranteed for a period of stated in the purchase agreement. In any case, please refer to the contract terms for other warranty conditions. The warranty is void if:

- a) The pump has been used for purposes that differ from that agreed.
- b) The pump has been fit with an electric or diesel engine with performance greater than that indicated in the table.
- c) The required safety devices were un-adjusted or disconnected.
- d) The pump was used with accessories or spare parts not supplied by General Pump.
- e) Damage was caused by:
 - 1) improper use
 - 2) the non-observance of maintenance instructions
 - 3) use not compliant with operating instructions
 - 4) insufficient flow rate
 - 5) faulty installation
 - 6) incorrect positioning or sizing of the hoses
 - 7) non-authorized design changes
 - 8) cavitation

15. TROUBLESHOOTING



The pump does not produce any noise at start-up:

- The pump is not primed and is running dry
- There is no water in the inlet line
- The valves are blocked
- The delivery line is closed and does not allow the air in the pump to be discharged



The pump pulses irregularly (knocking):

- Air suction
- Insufficient feeding
- Bends, elbows, fittings along the suction line obstruct the fluid's passage
- The inlet filter is dirty or too small
- The booster pump, where provided, supplies insufficient pressure or flow rate
- The pump is not primed due to insufficient head or the delivery line is closed during priming
- The pump is not primed due to valve seizing
- Worn valves
- Worn pressure packings
- Incorrect operation of the pressure adjustment valve
- Transmission problems



The pump does not deliver the rated flow / is noisy:

- Insufficient feeding (see the causes listed above)
- RPM are less than the rated flow
- Excessive amount of water by-passed by the pressure adjustment valve



- Worn valves
- Leakage from the pressure packings
- Cavitation due to:
 - 1) Wrong sizing of the suction hose/undersized diameters
 - 2) Insufficient flow rate
 - 3) High water temperature



Insufficient pump pressure:

- The nozzle (or has become) too large
- Insufficient RPM
- Leakage from the pressure packings
- Incorrect operation of the pressure adjustment valve
- Worn valves

15. TROUBLESHOOTING



Overheated pump:

- The pump is overloaded (pressure or RPM exceed the rated values)
- Oil level is too low, or the oil is not of a suitable type, indicated in Chapter 7 (see paragraph 7.4)
- Incorrect alignment of the joint or pulleys
- Excessive inclination of the pump during operation



Pump vibrations or knocking:

- Air suction
- Incorrect operation of the pressure adjustment valve
- Valve malfunction
- Irregular drive transmission motion

16. EXPLODED VIEW AND PARTS LIST

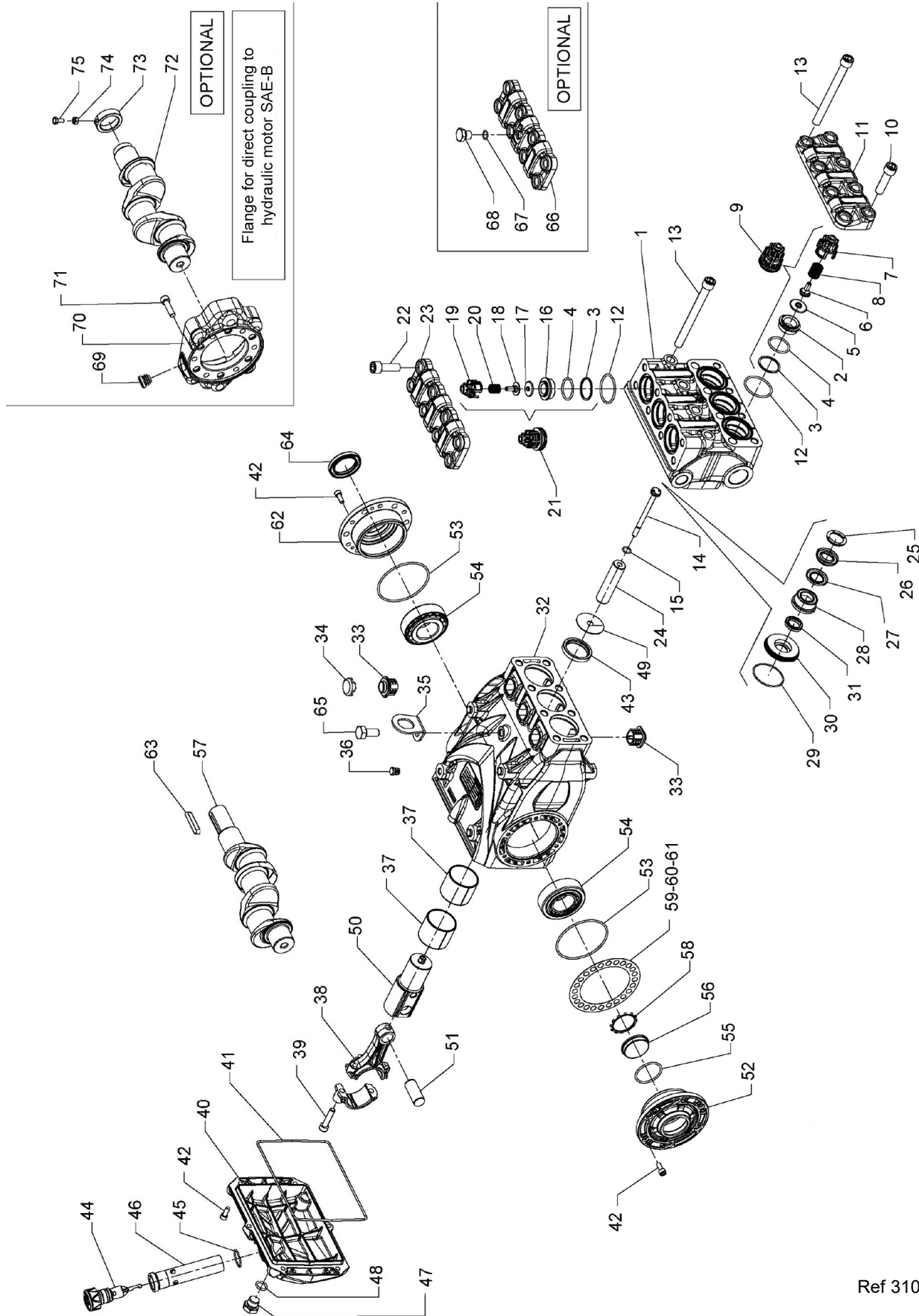

Parts List

Item	Part #	Description	QTY.
1	F64120415	MANIFOLD Ø20-22, NPT	1
	F64120515	MANIFOLD Ø25-26, NPT	
	F64120615	MANIFOLD Ø28, NPT	
2	F36204866	INTAKE VALVE SEAT	3
3	F90517800	ANTI-EXTRUSION RING Ø 31.0x35.5x1.5	6
4	90386500	O-RING Ø 29.82x2.62	6
5	F36216266	VALVE, SPHERICAL	3
6	F36216151	INTERNAL INTAKE VALVE GUIDE	3
7	F36216005	INTAKE VALVE GUIDE	3
8	F94744700	SPRING, Ø 15.9x24.3	3
9	F36727701	INTAKE VALVE ASSEMBLY	3
10	F99432500	SCREW, M12x45	4
11	F64211015	INTAKE VALVE COVER	1
12	F90387950	O-RING Ø 40.95x2.62	6
13	F99446700	SCREW M12x130	8
14	F64210936	PLUNGER SCREW	3
15	90358400	O-RING, Ø 10.82x1.78	3
16	F36203866	VALVE SEAT	3
17	F36209966	VALVE, SPHERICAL, INLET	3
18	F36210151	INTERNAL OUTLET VALVE GUIDE	3
19	F36213805	OUTLET VALVE GUIDE	3
20	F94740100	SPRING, VALVE, DELIVERY	3
21	F36713401	OUTLET VALVE ASSEMBLY	3
22	F99429500	SCREW, M12x35	8
23	F64210115	OUTLET VALVE COVER	1
24	F64040109	PLUNGER, Ø 20x77	3
	F64040209	PLUNGER, Ø 22x77	
	F64040309	PLUNGER, Ø 25x77	
	F64040409	PLUNGER, Ø 26x77	
	F64040509	PLUNGER, Ø 28x77	
25	47100051	HEAD RING, Ø 20	3
	F46100051	HEAD RING, Ø 22	
	F71100151	HEAD RING, Ø 25	
	F64100051	HEAD RING, Ø 26	
	F71100351	HEAD RING, Ø 28	
26	90270500	PACKING, Ø 20.0x35.0x7.5, HP	3
	90272500	PACKING, Ø 22.0x35.0x7.0, HP	
	F90274900	PACKING, Ø 25.0x38.0x7.0/4.6, HP	
	F90274990	PACKING, Ø 26.0x38.0x6.0/3.5, HP	
	F90275800	PACKING, Ø 28.0x45.0x8.5/5.0, HP	
27	660270	RESTOP RING, Ø 20.0x35.0x5.5/2.0	3
	90273000	RESTOP RING, Ø 22.0x35.0x5.5/2.0	
	F90274800	RESTOP RING, Ø 25.0x38.0x5.0/2.1	
	F90274980	RESTOP RING, Ø 26.0x38.0x5.5/3.0	
	F90275500	RESTOP RING, Ø 28.0x45.0x8.5/4.0	
28	F64210470	INTERMEDIATE RING, Ø 20	3
	F64210570	INTERMEDIATE RING, Ø 22	
	F64210670	INTERMEDIATE RING, Ø 25	
	F64210770	INTERMEDIATE RING, Ø 26	
	F64210870	INTERMEDIATE RING, Ø 28	
29	F90362400	O-RING, Ø 47.35x1.78	3
30	F64080170	LP SEAL RETAINER, Ø 20	3
	F64080270	LP SEAL RETAINER, Ø 22	
	F64080370	LP SEAL RETAINER, Ø 25	
	F64080470	LP SEAL RETAINER, Ø 26	
	F64080570	LP SEAL RETAINER, Ø 28	
31	F90268800	PACKING, Ø 20.0x28.0x5.5 LP	3
	F90271300	PACKING, Ø 22.0x30.0x5.5 LP	
	F90274600	PACKING, Ø 25.0x33.0x5.5 LP	
	F90274910	PACKING, Ø 26.0x34.0x5.4 LP	
	F90275000	PACKING, Ø 28.0x36.0x5.5 LP	

Item	Part #	Description	QTY.
32	F64010022	CRANKCASE	1
33	F70222551	CAP	6
34	F71225951	CRANKCASE CAP	3
35	F71223074	LIFTING BRACKET	1
36	F98200200	PLUG, M10	4
37	F90918550	BUSHING, Ø 45.0x49.0x40.0	6
38	F64030001	CONNECTING ROD, COMPLETE	3
39	99309900	CONNECTING ROD SCREW	6
40	F64160022	REAR COVER	1
41	F90393500	O-RING, Ø 171.12x2.62	1
42	F99185400	SCREW, M16x16	18
43	F90167600	OIL SEAL	3
44	F98211400	OIL DIPSTICK, Ø 21.5x58	1
45	90360400	O-RING, Ø 25.12x1.78	1
46	F72210695	DIPSTICK TUBE	1
47	98210050	PLUG, G3/8"x13	1
48	90383300	O-RING, Ø 13.95x2.62	1
49	F96709900	WASHER, 10.0x45.0x1.0	3
50	F64050022	PLUNGER GUIDE	3
51	F97742500	PIN, Ø 18.0x45.0	3
52	F70150122	BEARING SIDE COVER	1
53	F90391500	O-RING, Ø 80.60x2.62	2
54	91847300	BEARING	2
55	90387700	O-RING, Ø 39.34x2.62	1
56	70211801	OIL LEVEL SIGHT GLASS	1
57	F64020035	CRANK SHAFT	1
58	90075600	RETAINER CLIP	1
59	F70220081	SHIM, 0.10	1
60	F70220381	SHIM, 0.25	1
61	F70220581	SHIM, 0.35	1
62	F70150022	SIDE COVER	1
63	F91489500	KEY, 8x7x45	1
64	90166800	OIL SEAL Ø 35.0X52.0X7.0	1
65	99426600	SCREW M12X25	1
66	F64210215	OUTLET VALVE COVER, G1/4"	1
67	90358500	O-RING, Ø 10.82x1.78	1
68	F98204700	PLUG, G1/4"x13	1
69	F90206500	HOLE PLUG M18	1
70	F10085322	FLANGE, SAE-B	1
71	99308400	SCREW, M8x30	6
72	F64020135	CRANKSHAFT, SAE-B	1
73	F70226771	STOP RING, Ø 30	1
74	92202500	NUT, M6x5.0	1
75	F70227034	SCREW, M6x12, REFLECTOR	1
	200081	FEET BOLTS, M10-1.5x22, OPTIONAL	4
	96710600	FEET LOCK WASHERS, M10, OPTIONAL	4

REPAIR KITS

KIT NUMBER	F2470 (EV20) Plunger Pack.	F2471 (EV22) Plunger Pack.	F2472 (EV25) Plunger Pack.	F2473 (EV26) Plunger Pack.	F2474 (EV28) Plunger Pack.	F2468 Inlet Valve	F2001 Outlet Valve
Positions Included	26, 27, 29, 31	26, 27, 29, 31	26, 27, 29, 31	26, 27, 29, 31	26, 27, 29, 31	3,4,9	3,4,21

KIT NUMBER	F2476 (EV20) Complete Seals Kit	F2477 (EV22) Complete Seals Kit	F2478 (EV25) Complete Seals Kit	F2479 (EV26) Complete Seals Kit	F2480 (EV28) Complete Seals Kit
Positions Included	3,4,12, 15, 26, 27, 29, 31, 41, 43, 45, 48, 53, 55, 64	3,4,12, 15, 26, 27, 29, 31, 41, 43, 45, 48, 53, 55, 64	3,4,12, 15, 26, 27, 29, 31, 41, 43, 45, 48, 53, 55, 64	3,4,12, 15, 26, 27, 29, 31, 41, 43, 45, 48, 53, 55, 64	3,4,12, 15, 26, 27, 29, 31, 41, 43, 45, 48, 53, 55, 64

17. MAINTENANCE LOG

HOURS & DATE

OIL CHANGE							
GREASE							
PACKING REPLACEMENT							
PLUNGER REPLACEMENT							
VALVE REPLACEMENT							



GP Companies, Inc.
1174 Northland Drive
Mendota Heights, MN 55120
Phone: 651.686.2199 Fax: 800.535.1745
www.generalpump.com email: sales@gpcompanies.com

Ref 310209 Rev. E
06-23