

**FEATURES**

- Durable forged brass manifold
- Dust protection chamber
- Solid ceramic plungers
- Advanced plunger mounting system
- Valve cover for ease of service

**SPECIFICATIONS**

<b>Pump Model</b>	ETB1508S34
Maximum Volume	3.4 GPM
Maximum Discharge Pressure	2,610 PSI
Horsepower	6.1 EBHP
Maximum Pump Speed	3400 RPM
Maximum Inlet Pressure	125 PSI
Max. Inlet Vacuum	3 ft. water (2.6 Hg)
Plunger Bore (in / mm)	.591 in./15 mm
Plunger Stroke (in / mm)	.315 in./8 mm
Oil Capacity	8.5 oz.
Maximum Fluid Temperature	165° F
Inlet Port Thread	1/2"-14 BSP-F
Discharge Port Thread	3/8"-19 BSP-F
Shaft Diameter	.945 in./24 mm
Weight	11.0 lbs.
Dimensions - Nominal	8" x 7.4" x 4.7"

TRIPLEX

TRIPLEX



General Pump  
is a member of  
the Interpump Group



Ref 301107 Rev. D  
08-23



# Instructions and Recommendations for the Installation of *ETB Series Pumps*

Maximum temperature of the water through the pump is 165°F (73°C).

In order to obtain maximum performance in terms of duration of seals and valves, it is necessary to respect a few simple rules, as follows:

**1) In order to avoid damage caused by cavitation, the pump must be pressure fed.**

The higher the inlet pressure, the longer the life of the wet end of the pump.

When working at 165°F (73°C), the minimum feed pressure - measured directly in the inlet port of the pump when it is working - is 45 psi (3 bar).

The minimum feed pressure according to the different temperatures are:

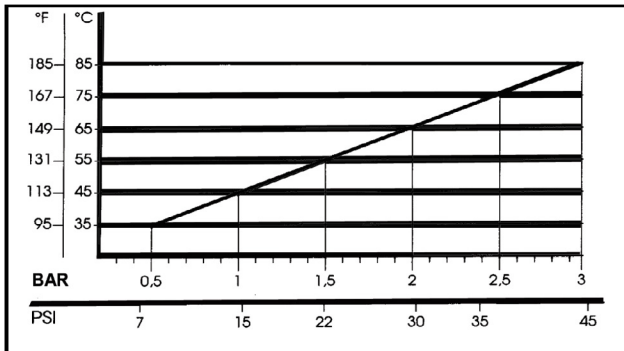

Naturally, if the application allows for feeding the pump with 45 psi (3 bar) even at low temperatures (for example: 115°F/45°C the life of the wet end of the pump will be even longer.

**2) The plumbing which feeds the pump must be of a diameter at least equal to the inlet port.**

Also, follow the suggestions below:

a) Make the plumbing as short and straight as possible, preferably in an upward direction to facilitate the expulsion of eventual air bubbles naturally if compatible with the requirements of the system.

b) It is always useful to put a filter at the inlet with capacity of 4 to 5 times the flow of

the pump, for example for a 4 gpm (15 l/min) pump, put a filter from 16 to 20 gpm (60-75 l/min). The mesh size suitable for this application is 0.016" (.4 mm).

c) It is extremely important to put a pressure switch on the suction port of the pump, and in any case downstream from the filter, so that it can stop the pump should the feed pressure drop by 20% due to the filter clogging or failure of the feed pump, etc.

**3) Change of oil**

We recommend the **first oil change after the first 50 hours**, with the **pump stopped** and the **oil still warm**.

This change is not recommended because the oil has lost its properties, but rather to eliminate the impurities that have gotten into the oil during the running-in phase. If these impurities are not removed, but are allowed to remain in the oil, they *may cause premature wear* to the moving parts and the oil seals. **After this initial change, the oil can then be changed every three months or 300 hours of operation thereafter.**

Please note: If the pump works in conditions with high humidity and with sharp temperature changes, it is possible that condensation will appear inside the crankcase, which mixing with the oil can change its properties. This is easy to see because the oil changes to a white, milky color.

If the pump does not have excessive water leaking from the packings, and the oil becomes milky, the oil has to be changed more frequently. The percentage of water in the oil must not exceed 20%.

**Use oil per the following chart:**

CHART OF COMPATIBLE OILS	
General Pump	Series 100
BP	VISCO 2000
CASTROL	CWX
MOBIL	SUPER
SHELL	HELIX SUPER
TOTAL	QUARTZ 4000-5000

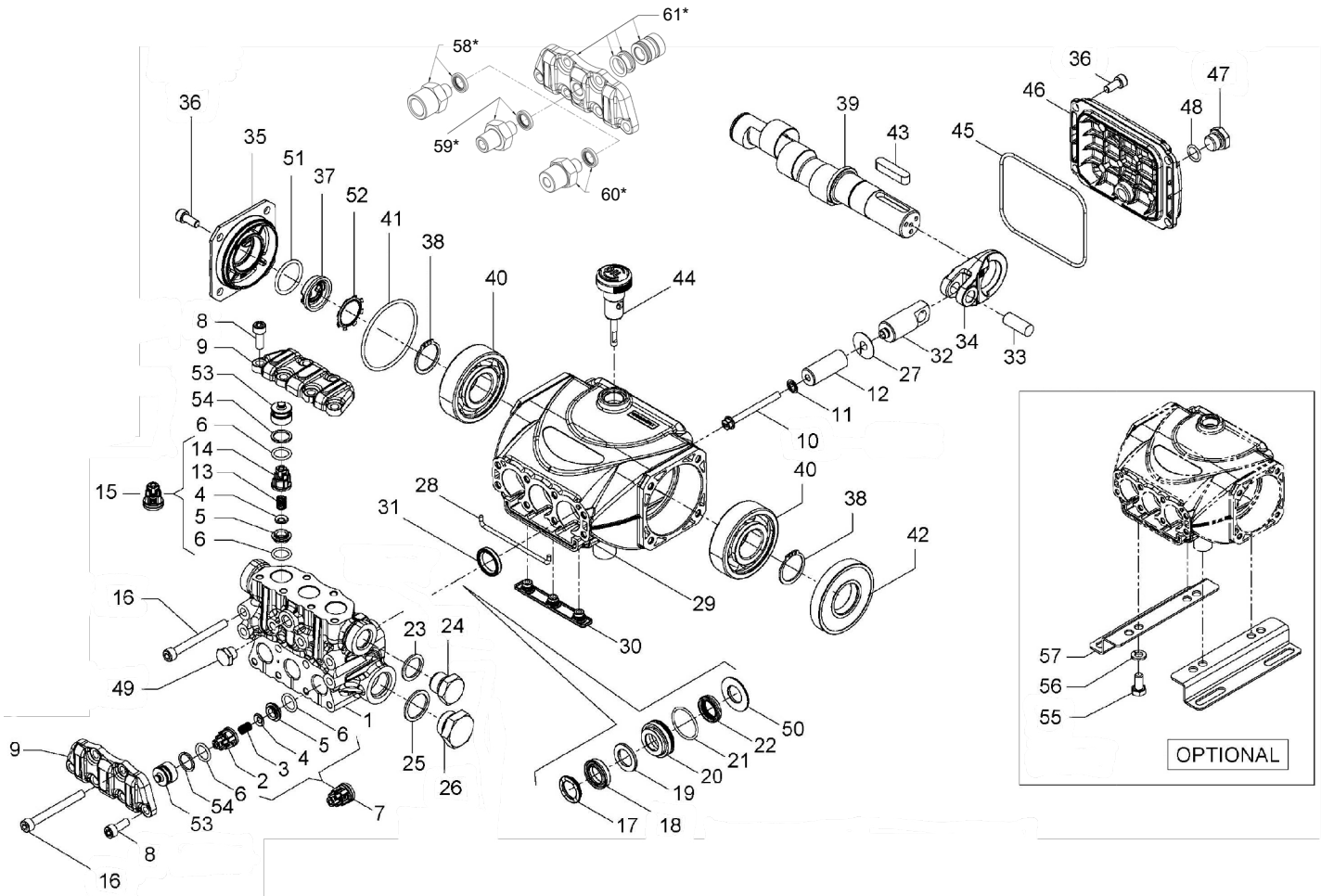

### PARTS LIST

ITEM	PART NO.	DESCRIPTION	QTY	ITEM	PART NO.	DESCRIPTION	QTY	ITEM	PART NO.	DESCRIPTION	QTY
1.	53122941	Manifold, Ø 15	1	22.	90260800	Packing, Ø 15, LP	3	44.	98210800	Oil Dipstick	1
2.	36211951	Inlet Valve Guide	3	710030	Packing, Ø 15, LP	(K312H, K313H)	3	45.	90391700	O-ring, Ø 88.57x2.62	1
3.	94732600	Spring, Ø 6x12	3	23.	93738000	Washer, Ø17.5x23x1.5	1	46.	53160022	Rear Cover	1
4.	36211276	Valve, Spherical	6	24.	98210000	Plug, 3/8"x13	1	47.	98204250	Plug, 1/4"x9	1
5.	36211366	Valve Seat	12	25.	96751400	Washer, Ø	1	48.	701013	O-ring, Ø 10.82x1.78	1
6.	90367400	O-ring, Ø12.0x2.0	6	26.	98217600	Plug, G1/2"x10	1	49.	98196600	Plug, 1/8"x8	1
7.	36722401	Valve Assembly	3	27.	96699000	Gasket, Ø 7.5x23x0.5	3	50.	53210670	Support Ring, Ø15	3
8.	99186700	Screw, M8x16	14	28.	53210382	Gasket, Ø3x85	1	51.	90385900	O-ring, Ø 25.7x2.62	1
9.	53212015	Valve Cover	2	29.	53010022	Crankcase	1	52.	90067100	Stop Ring	1
10.	99169000	Plunger Bolt, M5x55	3	30.	58210451	Drip Cover	1	53.	36217851	Inlet/Outlet Valve Cap	6
11.	96690500	Washer, Ø 5x11.5x0.4	3	31.	90159300	Oil Seal, Ø 18x24x4.4	3	54.	90509300	Ring, Ø 16.4x13.2x1.3	6
12.	53040009	Plunger, Ø 15x42	3	32.	53050066	Piston Guide	3	55.	99303700	Screw, M8x16	4
	63040509	Plunger, Ø 18x42	3	33.	97733800	Piston Pin, Ø 10x26.5	3	56.	96701600	Washer, Ø 8.4x14.4x2.0	4
13.	94733300	Spring, Ø 6.2x10.4	3	34.	53030022	Connecting Rod	3	57.	50200074	Pump Foot	2
14.	36211151	Outlet Valve Cage Guide	3	35.	53150022	Crankcase Side Cover	1	58.*	101162	Kit, ADTR, 1/4"-F, SS, W/Seal	1
15.	36719301	Complete Outlet Valve	3	36.	99183700	Screw, M6x16	8	59.*	101157	Kit, ADTR, 1/4"-M, SS, W/Seal	1
16.	99199600	Screw, M6x70	8	37.	53210851	Oil Sight Glass	1	60.*	101158	Kit, ADTR, 3/8"-K, SS, W/Seal	1
17.	63101051	Head Ring, Ø 15	3	38.	90063500	Stop Ring	2	61.*	K424	Kit, Tapped Valve Plate	1
18.	90261100	Packing, Ø 15, HP	3	39.	60020965	Crankshaft, 8 mm	1			W/ Valve Spacer & Seals	
	710031	Packing, Ø 15, HP	(K312H, K313H)	40.	91832800	Bearing, Premium	2				
19.	90508990	Anti-ext. Ring, Ø 15	3	41.	90389800	O-ring, Ø 56.82x2.62	1				
20.	53210170	Support Ring, Ø 15	3	42.	90164100	Oil Seal, Ø 25x62x10	1				
21.	90360400	O-ring, 25.12x1.78	3	43.	91489200	Key, 8x7x35	1				

\* Optional Parts

\*\* 53150001 Oil Level Indicator Assembled W/O Screws and O-ring

**REPAIR KITS**

**TORQUE SPECS\***

KIT NO.	K309	K311	Ø 15			
			K312	K312H' (Hot Kit)	K313	K313H' (Hot Kit)
ITEM NO'S INCLUDED IN KIT	2, 3, 4, 5, 6, 13, 14, (7), (15)	31	17, 18, 19, 21, 22	18, 22	17, 18, 19, 20, 21, 22, 50	17, 18, 19, 20, 21, 22, 50
NUMBER OF ASSY'S IN KIT	6	3	3	3	1	3
NO. OF CYLINDERS KIT SERVICES	3	3	3	3	1	3

Position	Ft.-Lbs.	Nm.
8	8.9	12
10	4.4	6
16	8.9	12
24**	30	40
26	30	40
36	7.4	10
47	14.8	20
49**	9.6	13
55	14.8	20

\*Decrease torque by 20% if threads are lubricated.  
\*\*Use Loctite 542 Red

<sup>1</sup> Note: Seal tools included

**DIMENSIONS**

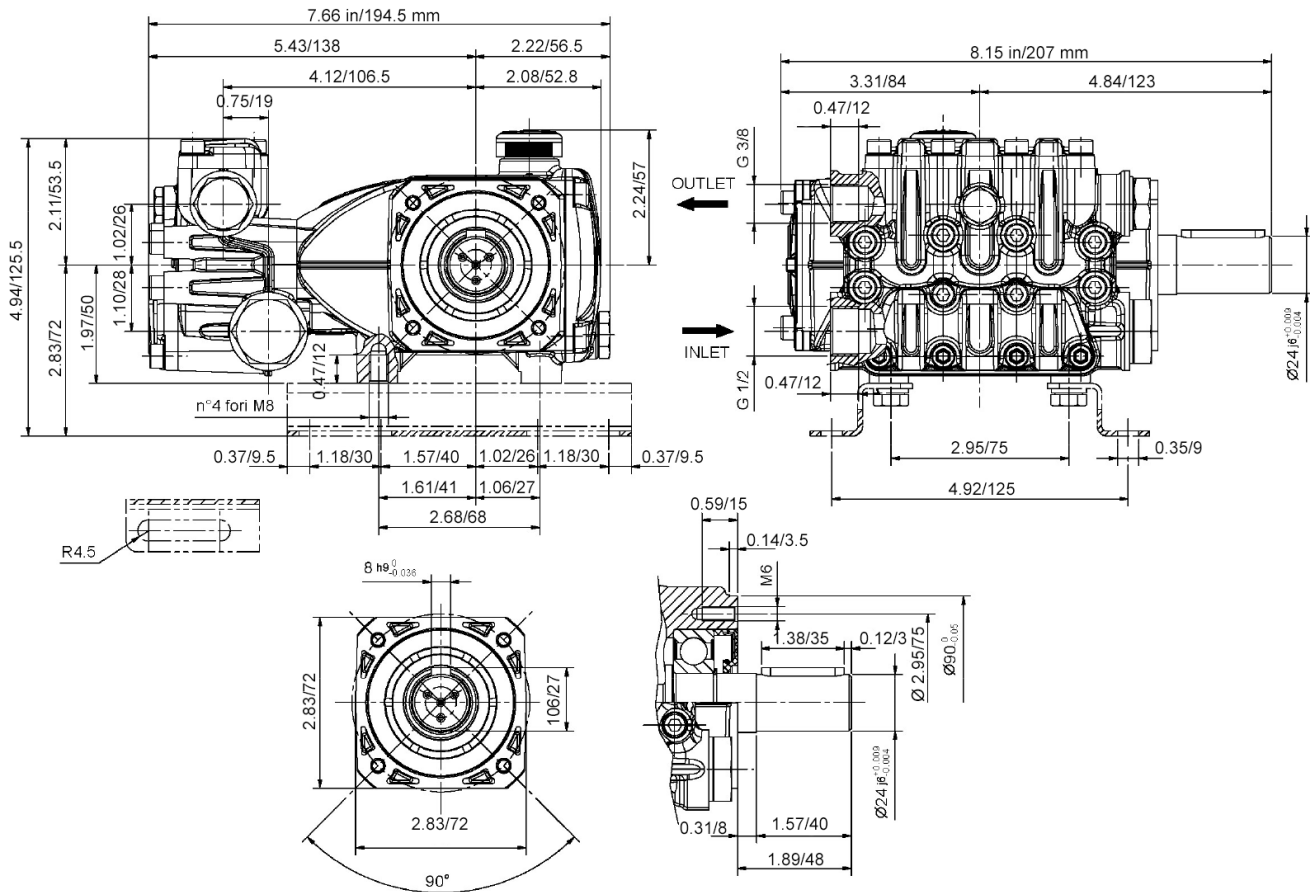

**WARNING: High Pressure Systems require a primary pressure regulating device (i.e. regulator, unloader) and a secondary pressure relief device (i.e. pop-off valve, relief valve). Failure to install such relief devices properly could result in personal injury or damage to pump or property. GP does not assume any liability or responsibility for the operation of the user's high pressure system.**

**WARNING:** This product can expose you to chemicals including lead, which is known to the state of California to cause cancer and birth defects or other reproductive harm. For more information, go to [www.P65Warnings.ca.gov](http://www.P65Warnings.ca.gov)

