

Triplex Plunger Pump, Solid Shaft, SS, 1750 RPM

FEATURES

- 316 SS fluid end for superior corrosion resistance
- New Generation seal package
- Dust protection chamber
- Solid ceramic plungers
- Oversized plunger guide
- Optimized inlet and outlet valves
- Oversized crankcase

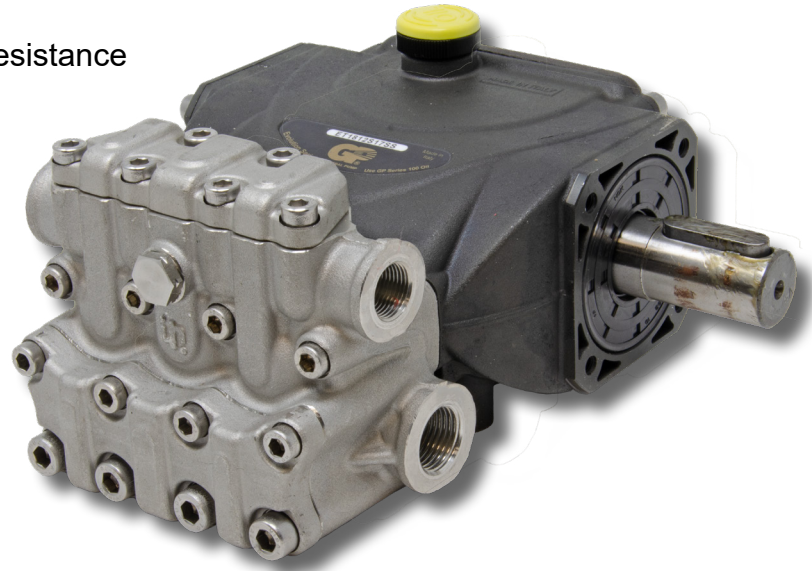

SPECIFICATIONS

Pump Model	ET1506S17SS(L)	ET1509S17SS(L)	ET1511S17SS(L)	ET1810S17SS(L)	ET1812S17SS(L)
Maximum Volume	1.6 GPM	2.4 GPM	2.9 GPM	3.4 GPM	4.0 GPM
Maximum Discharge Pressure	2,175 PSI				
Horsepower	2.4 EBHP	3.6 EBHP	4.3 EBHP	5.0 EBHP	6.0 EBHP
Maximum Pump Speed	1750 RPM				
Maximum Inlet Pressure	125 PSI				
Max. Inlet Vacuum	3 ft. water (2.6 Hg)				
Plunger Bore (in / mm)	.591 in./15 mm	.591 in./15 mm	.591 in./15 mm	.708 in./18 mm	.708 in./18 mm
Plunger Stroke (in / mm)	.236 in./6.0 mm	.354 in./9.0 mm	.452 in./11.5 mm	.393 in./10 mm	.472 in./12 mm
Oil Capacity	8.5 oz.				
Maximum Fluid Temperature	165° F				
Inlet Port Thread	1/2"-14 BSP-F				
Discharge Port Thread	3/8"-19 BSP-F				
Shaft Diameter	.945 in./24 mm				
Weight	11.0 lbs.				
Dimensions - Nominal	8" x 7.4" x 4.7"				

TRIPLEX

TRIPLEX

Instructions and Recommendations for the Installation of *ET Series Pumps*

Maximum temperature of the water through the pump is 165°F (73°C).

In order to obtain maximum performance in terms of duration of seals and valves, it is necessary to respect a few simple rules, as follows:

1) **In order to avoid damage caused by cavitation, the pump must be pressure fed.**

The higher the inlet pressure, the longer the life of the wet end of the pump.

When working at 165°F (73°C), the minimum feed pressure - measured directly in the inlet port of the pump when it is working - is 45 psi (3 bar).

The minimum feed pressure according to the different temperatures are:

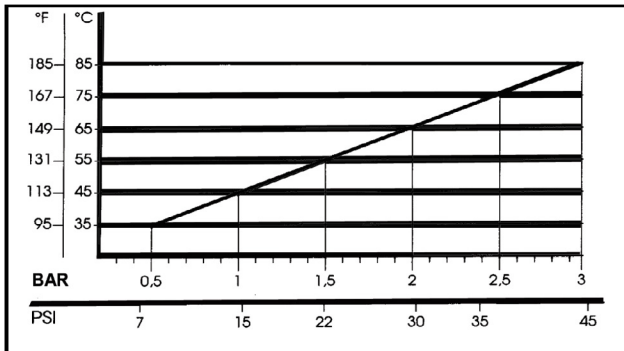

Naturally, if the application allows for feeding the pump with 45 psi (3 bar) even at low temperatures (for example: 115°F/45°C the life of the wet end of the pump will be even longer.

2) **The plumbing which feeds the pump must be of a diameter at least equal to the inlet port.**

Also, follow the suggestions below:

a) Make the plumbing as short and straight as possible, preferably in an upward direction to facilitate the expulsion of eventual air bubbles naturally if compatible with the requirements of the system.

b) It is always useful to put a filter at the inlet with capacity of 4 to 5 times the flow of

the pump, for example for a 4 gpm (15 l/min) pump, put a filter from 16 to 20 gpm (60-75 l/min). The mesh size suitable for this application is 0.016" (.4 mm).

c) It is extremely important to put a pressure switch on the suction port of the pump, and in any case downstream from the filter, so that it can stop the pump should the feed pressure drop by 20% due to the filter clogging or failure of the feed pump, etc.

3) **Change of oil**

We recommend the **first oil change after the first 50 hours**, with the **pump stopped** and the **oil still warm**.

This change is not recommended because the oil has lost its properties, but rather to eliminate the impurities that have gotten into the oil during the running-in phase. If these impurities are not removed, but are allowed to remain in the oil, they *may cause premature wear* to the moving parts and the oil seals. **After this initial change, the oil can then be changed every three months or 300 hours of operation thereafter.**

Please note: If the pump works in conditions with high humidity and with sharp temperature changes, it is possible that condensation will appear inside the crankcase, which mixing with the oil can change its properties. This is easy to see because the oil changes to a white, milky color.

If the pump does not have excessive water leaking from the packings, and the oil becomes milky, the oil has to be changed more frequently. The percentage of water in the oil must not exceed 20%.

Use oil per the following chart:

CHART OF COMPATIBLE OILS	
General Pump	Series 100
BP	VISCO 2000
CASTROL	CWX
MOBIL	SUPER
SHELL	HELIX SUPER
TOTAL	QUARTZ 4000-5000

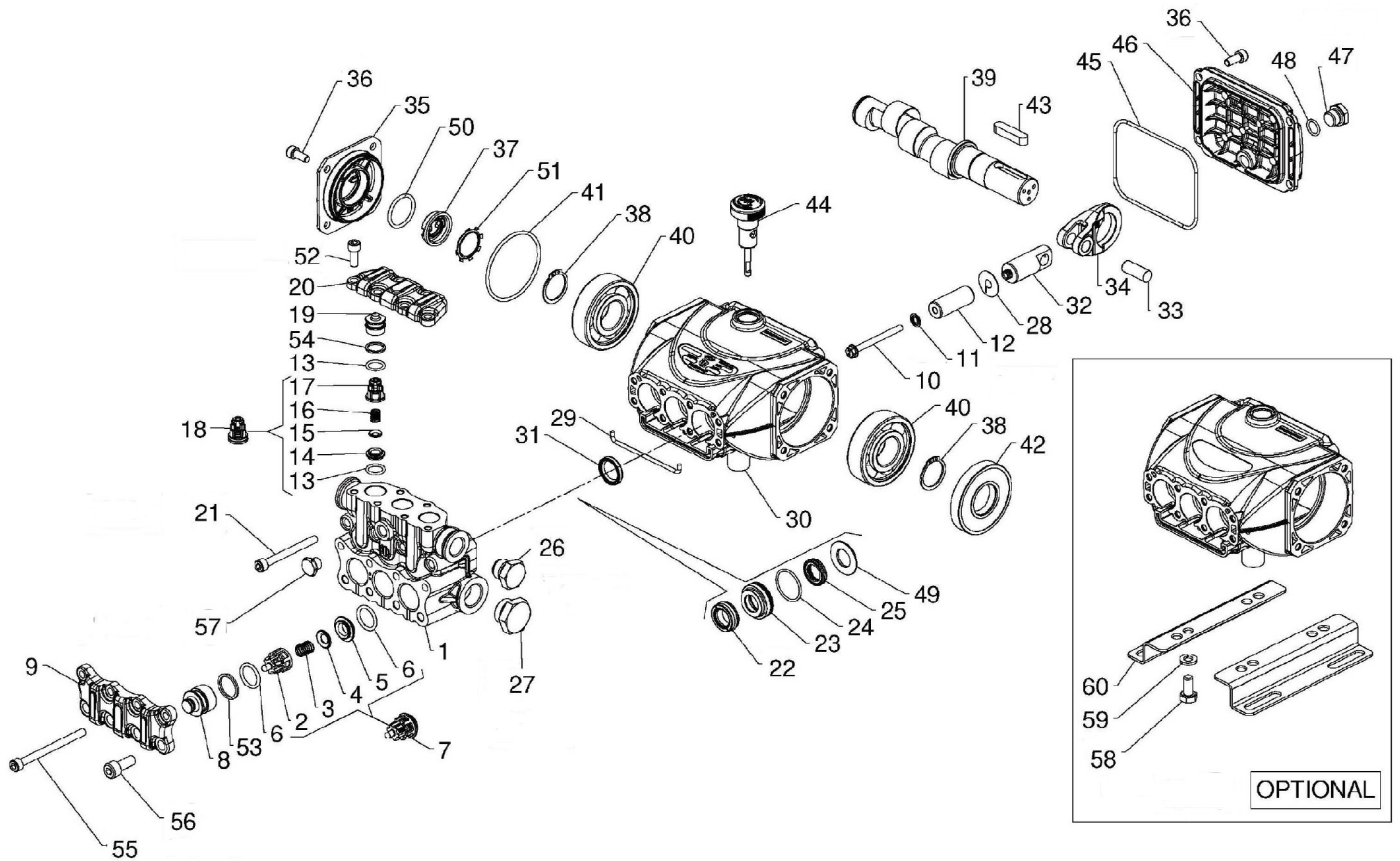

PARTS LIST

ITEM	PART NO.	DESCRIPTION	QTY	ITEM	PART NO.	DESCRIPTION	QTY	ITEM	PART NO.	DESCRIPTION	QTY
1.	53123836	Manifold, Ø 15	1	23.	90221000	Packing, Ø 18, HP	3	39.	53020135	Crankshaft, 12.0 mm (ET151S17SS, ET1812S17SS)	1
2.	36202551	Inlet Valve Guide	3	24.	53211656	Support Gasket, Ø 15	3	40.	91832800	Premium Bearing	2
3.	94737300	Spring, Ø 9.4x14.8	3	25.	90260900	Packing, Ø 15, LP	3	41.	90389800	O-ring, Ø56.82x2.62	1
4.	36200176	Valve, Spherical	3	26.	90265050	Packing, Ø 18, LP	3	42.	90164100	Oil Seal, Ø25x62x10	1
5.	36203666	Valve Seat	3	27.	90360400	O-ring, 25.12x1.78	3	43.	91489200	Crankshaft Key	1
6.	701115	O-ring, Ø17.13x2.62	3	28.	98210066	Plug, G3/8"x13	1	44.	98210800	Oil Dipstick	1
7.	36713001	Valve Assembly	3	29.	98218000	Plug, G1/2"x13	1	45.	90391700	O-ring, Ø88.57X2.62	1
8.	53212556	Inlet/Outlet Valve Cap	3	30.	96699000	Washer, Ø7.5x23x.5	3	46.	53160022	Rear Cover	1
9.	53212336	Valve Plate	3	31.	53210382	Gasket, Ø3x85	1	47.	98204000	Plug, G1/4x9	1
10.	99169000	Plunger Bolt, M5x55	3	32.	53010022	Crankcase	1	48.	701013	O-ring, Ø10.82x1.78	1
11.	96690500	Washer, Ø 5x11.5x0.4	3	33.	90159300	Oil Seal, Ø18x24x4	3	49.	53211756	Support Ring Ø15	3
12.	53040009	Plunger, Ø 15x42	3	34.	53050166	Plunger Guide	3	50.	53211556	Support Ring Ø18	3
13.	53040009	Plunger, Ø 18x42	3	35.	97733800	Pin, Ø10x26.5	3	51.	90385900	O-ring, Ø25.07x2.62	1
14.	90359300	O-ring, Ø 12x2	6	36.	53030022	Connecting Rod	3	52.	90067100	Stop Ring	1
15.	53211166	Valve Seat	3	37.	53150022	Side Cover	1	53.	99186800	Screw, M6x18	6
16.	36211276	Valve, Spherical	3	38.	99183800	Screw, M6x14	8	54.	90514650	Ring, Ø22.4x18.3x1.5	3
17.	94733300	Spring, Ø6.7x10.8	3	39.	53210851	Oil Sight Glass	1	55.	90509300	Ring, Ø16.4x13.2x1.3	3
18.	36211151	Outlet Valve Cage Guide	3	40.	90063500	Stop Ring	2	56.	99199830	Screw, M6x75	4
19.	36724501	Complete Outlet Valve	3	41.	60020765	Crankshaft, 7.2 mm (ET1506S17SS)	1	57.	99305800	Screw, M8x25	4
20.	36217851	Inlet/Outlet Valve Cap	3	42.	60028335	Crankshaft, 10.0 mm (ET1509S17SS, ET1810S17SS)	1	58.	98192700	Plug, G1/8x8	1
21.	53212436	Valve Plate	3	43.				59.	99303700	Screw, M8x16	4
22.	99199200	Screw, M6x60	8	44.				60.	96701600	Washer, Ø.4x14.4x2.0	4
	90216000	Packing, Ø 15, HP	3	45.					50200074	Pump Feet	2

REPAIR KITS

KIT NO.	K341	K334	K311	Ø 15		Ø 18	
				K381	K383	K382	K384
ITEM NO'S INCLUDED IN KIT	2, 3, 4, 5, 6, (7)	13, 14, 15, 16, 17, (18)	31	22, 24, 25	22, 23, 24, 25, 49	22, 24, 25	22, 23, 24, 26, 49
NUMBER OF ASSY'S IN KIT	6	6	3	3	1	3	1
NO. OF CYLINDERS KIT SERVICES	3	3	3	3	1	3	1

TORQUE SPECS*

Position	Ft.-Lbs.	Nm.
10	4.4	6
21	8.9	12
26	29.5	40
27	29.5	40
36	7.4	10
47	14.8	20
52	8.9	12
55	8.9	12
56	41.3	30
57	9.6	13
58	14.8	20

*Decrease torque by 20% if threads are lubricated.
**Use Loctite 542 Red

DIMENSIONS

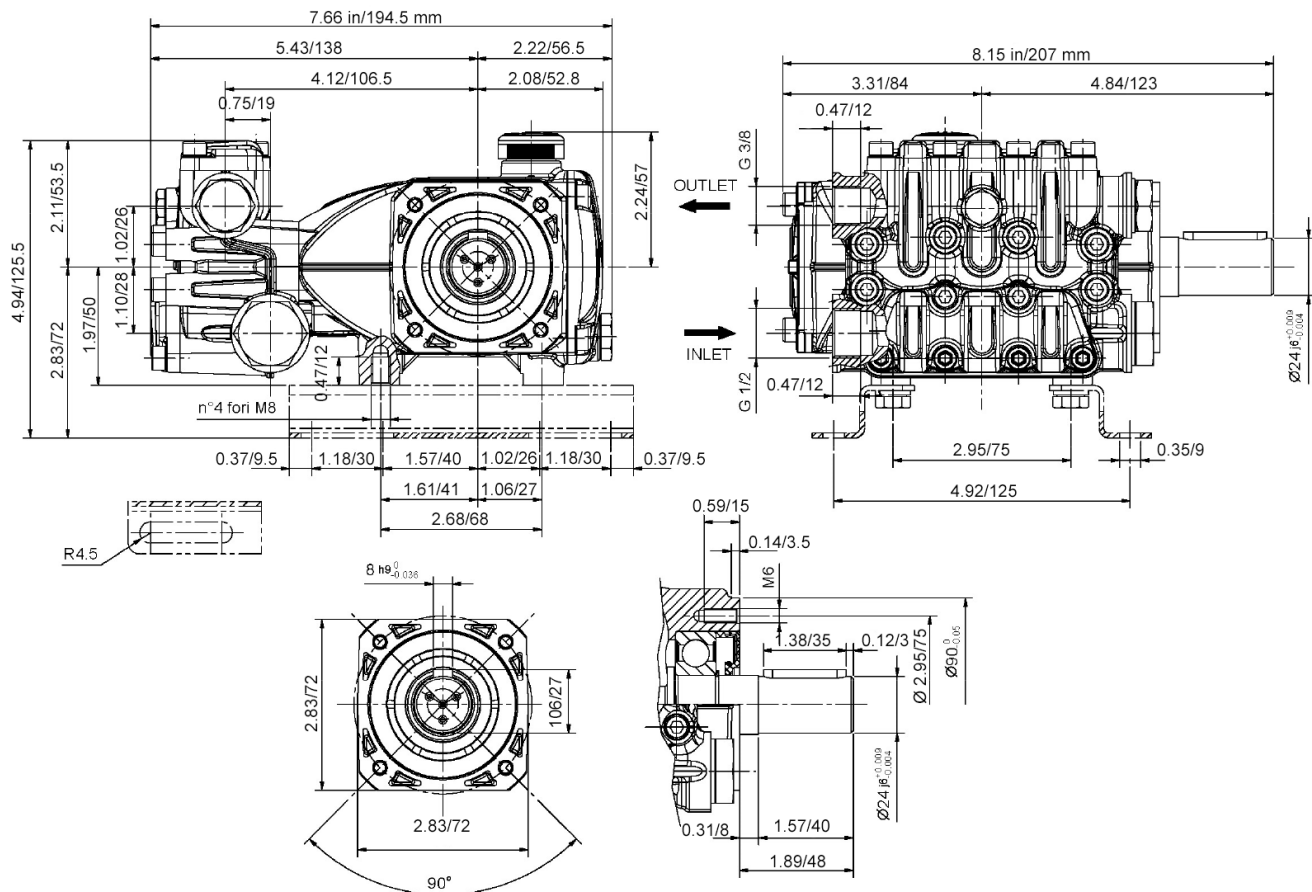

WARNING: High Pressure Systems require a primary pressure regulating device (i.e. regulator, unloader) and a secondary pressure relief device (i.e. pop-off valve, relief valve). Failure to install such relief devices properly could result in personal injury or damage to pump or property. GP does not assume any liability or responsibility for the operation of the user's high pressure system.

