

FEATURES

- “HR” anti-corrosion surface treatment on manifold
- New generation seal package
- Dust protection chamber
- Solid ceramic plungers
- Oversized plunger guide
- Optimized inlet and outlet valves
- Oversized crankcase

**SPECIFICATIONS**

| Pump Model | ET1305S34 | ET1306S34 | ET1307S34 | ET1308S34 | ET1309S34 | ET1310S34 | ET1311S34 | ET1312S34 |
|----------------------------|------------------|-----------------|-----------------|---------------|---------------|----------------|----------------|------------------|
| Maximum Volume | 1.6 GPM | 1.9 GPM | 2.1 GPM | 2.4 GPM | 2.6 GPM | 2.9 GPM | 3.1 FPM | 3.4 GPM |
| Maximum Discharge Pressure | 4,450 PSI | | | | | | | |
| Horsepower | 4.8 EBHP | 5.6 EBHP | 6.4 EBHP | 7.2 EBHP | 8.1 EBHP | 8.9 EBHP | 9.7 EBHP | 10.5 EBHP |
| Maximum Pump Speed | 3400 RPM | | | | | | | |
| Maximum Inlet Pressure | 125 PSI | | | | | | | |
| Max. Inlet Vacuum | Flooded | | | | | | | |
| Plunger Bore (in / mm) | .512 in./13 mm | | | | | | | |
| Plunger Stroke (in / mm) | .197 in./5 mm | .256 in./6.5 mm | .283 in./7.2 mm | .315 in./8 mm | .354 in./9 mm | .394 in./10 mm | .433 in./11 mm | .453 in./11.5 mm |
| Oil Capacity | 8.5 oz. | | | | | | | |
| Maximum Fluid Temperature | 165° F | | | | | | | |
| Inlet Port Thread | 1/2"-14 BSP-F | | | | | | | |
| Discharge Port Thread | 3/8"-19 BSP-F | | | | | | | |
| Shaft Diameter | .945 in./24 mm | | | | | | | |
| Weight | 11.0 lbs. | | | | | | | |
| Dimensions - Nominal | 8" x 7.4" x 4.7" | | | | | | | |

TRIPLEX

TRIPLEX



Instructions and Recommendations for the Installation of *ET Series Pumps*

Maximum temperature of the water through the pump is 165°F (73°C).

In order to obtain maximum performance in terms of duration of seals and valves, it is necessary to respect a few simple rules, as follows:

1) **In order to avoid damage caused by cavitation, the pump must be pressure fed.**

The higher the inlet pressure, the longer the life of the wet end of the pump.

When working at 165°F (73°C), the minimum feed pressure - measured directly in the inlet port of the pump when it is working - is 45 psi (3 bar).

The minimum feed pressure according to the different temperatures are:

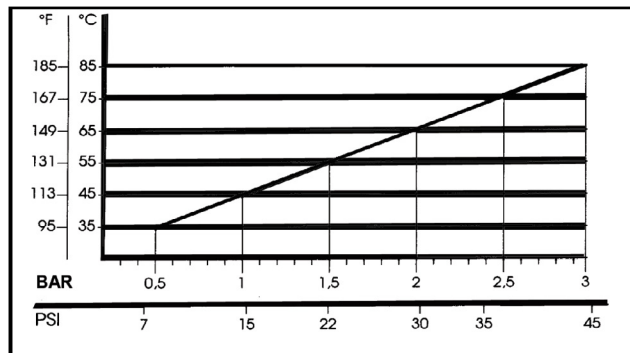

Naturally, if the application allows for feeding the pump with 45 psi (3 bar) even at low temperatures (for example: 115°F/45°C the life of the wet end of the pump will be even longer.

2) **The plumbing which feeds the pump must be of a diameter at least equal to the inlet port.**

Also, follow the suggestions below:

a) Make the plumbing as short and straight as possible, preferably in an upward direction to facilitate the expulsion of eventual air bubbles naturally if compatible with the requirements of the system.

b) It is always useful to put a filter at the inlet with capacity of 4 to 5 times the flow of

the pump, for example for a 4 gpm (15 l/min) pump, put a filter from 16 to 20 gpm (60-75 l/min). The mesh size suitable for this application is 0.016" (.4 mm).

c) It is extremely important to put a pressure switch on the suction port of the pump, and in any case downstream from the filter, so that it can stop the pump should the feed pressure drop by 20% due to the filter clogging or failure of the feed pump, etc.

3) **Change of oil**

We recommend the **first oil change after the first 50 hours**, with the **pump stopped** and the **oil still warm**.

This change is not recommended because the oil has lost its properties, but rather to eliminate the impurities that have gotten into the oil during the running-in phase. If these impurities are not removed, but are allowed to remain in the oil, they *may cause premature wear* to the moving parts and the oil seals. **After this initial change, the oil can then be changed every three months or 300 hours of operation thereafter.**

Please note: If the pump works in conditions with high humidity and with sharp temperature changes, it is possible that condensation will appear inside the crankcase, which mixing with the oil can change its properties. This is easy to see because the oil changes to a white, milky color.

If the pump does not have excessive water leaking from the packings, and the oil becomes milky, the oil has to be changed more frequently. The percentage of water in the oil must not exceed 20%.

Use oil per the following chart:

| CHART OF COMPATIBLE OILS | |
|--------------------------|------------------|
| General Pump | Series 100 |
| BP | VISCO 2000 |
| CASTROL | CWX |
| MOBIL | SUPER |
| SHELL | HELIX SUPER |
| TOTAL | QUARTZ 4000-5000 |

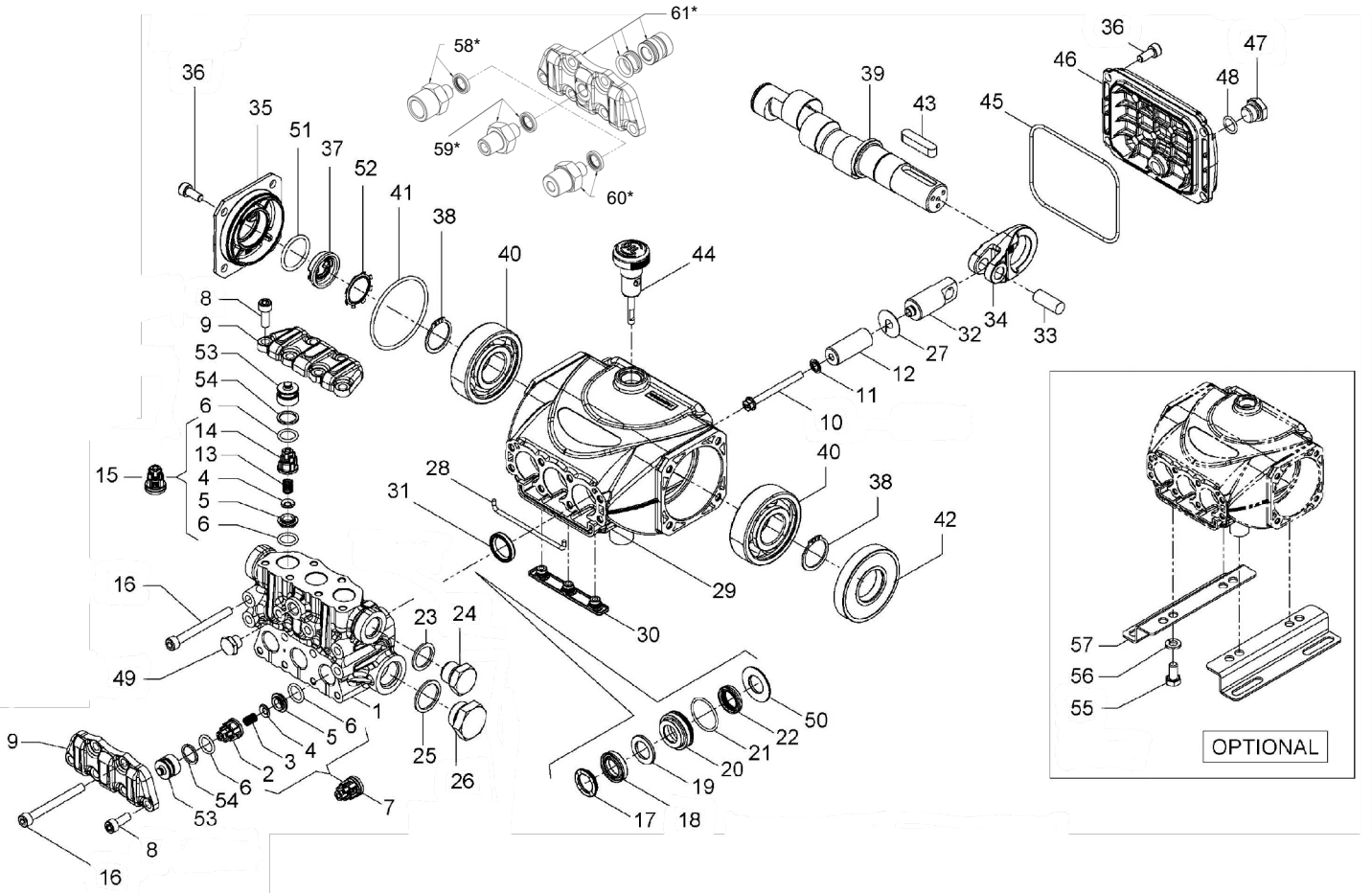

PARTS LIST

| ITEM | PART NO. | DESCRIPTION | QTY | ITEM | PART NO. | DESCRIPTION | QTY | ITEM | PART NO. | DESCRIPTION | QTY |
|------|----------|-------------------------|-----|------|----------|-----------------------|-----|----------|-------------------------|-------------------------------|-----|
| 1. | 53122015 | Manifold, Ø 13 | 1 | 27. | 96699000 | Gasket, Ø 7.5x23x0.5 | 3 | 60021735 | Crankshaft, 11.5 mm | 1 | |
| 2. | 36211951 | Inlet Valve Guide | 3 | 28. | 53210382 | Gasket, Ø3x85 | 1 | | (ET1312S34) | | |
| 3. | 94732600 | Spring, Ø 6x12 | 3 | 29. | 53010022 | Crankcase | 1 | 40. | 91833100 | Bearing, Premium | 2 |
| 4. | 36211276 | Valve, Spherical | 6 | 30. | 58210451 | Drip Cover | 1 | 41. | 90389800 | O-ring Ø 56.82x2.62 | 1 |
| 5. | 36211366 | Valve Seat | 6 | 31. | 90159300 | Oil Seal, Ø 18x24x4.4 | 3 | 42. | 90164100 | Oil Seal, Ø 25x62x10 | 1 |
| 6. | 90367400 | O-ring, Ø12.00x2.00 | 12 | 32. | 53050066 | Piston Guide | 3 | 43. | 91489200 | Key, 8x7x35 | 1 |
| 7. | 36722401 | Valve Assembly | 3 | 33. | 97733800 | Piston Pin, Ø 10x26.5 | 3 | 44. | 98210800 | Oil Dipstick | 1 |
| 8. | 99185400 | Screw, Mx16 | 10 | 34. | 53030022 | Connecting Rod | 3 | 45. | 90391700 | O-ring, Ø 88.57X2.62 | 1 |
| 9. | 53211815 | Valve Cover | 2 | 35. | 53150022 | Crankcase Side Cover | 1 | 46. | 53160022 | Rear Cover | 1 |
| 10. | 99169000 | Plunger Bolt, M5x55 | 3 | 36. | 99183700 | Screw, M4x14 | 8 | 47. | 98204250 | Plug, 1/4"x9 | 1 |
| 11. | 96690500 | Washer, Ø 5x11.5x0.4 | 3 | 37. | 53210851 | Oil Sight Glass | 1 | 48. | 701013 | O-ring, Ø 10.82x1.78 | 1 |
| 12. | 63040609 | Plunger, Ø 13x42 | 3 | 38. | 90063500 | Stop Ring, A25 | 2 | 49. | 98196800 | Plug, 1/8"x8 | 1 |
| 13. | 94733300 | Spring, Ø 6.2x10.4 | 3 | 39. | 60020265 | Crankshaft, 5 mm | 1 | 50. | 53210570 | Support Ring, Ø13 | 3 |
| 14. | 36211151 | Outlet Valve Cage Guide | 3 | | | (ET1305S34) | | 51. | 90385900 | O-ring, Ø 25.07x2.62 | 1 |
| 15. | 36719301 | Complete Outlet Valve | 3 | | 60020465 | Crankshaft, 6 mm | 1 | 52. | 90067100 | Stop Ring | 1 |
| 16. | 99199600 | Screw, M6x70 | 8 | | | (ET1306S34) | | 53. | 36217851 | Inlet/Outlet Valve Cap | 6 |
| 17. | 44100251 | Head Ring, Ø 13 | 3 | | 60020765 | Crankshaft, 7.2 mm | 1 | 54. | 90509300 | Ring, Ø 16.4x13.2x1.3 | 6 |
| 18. | 90260200 | Packing, Ø 13, HP | 3 | | | (ET1307S34) | | 55. | 99303700 | Screw, M8x16 | 4 |
| 19. | 90507650 | Anti-ext. Ring, Ø 13 | 3 | | 60020965 | Crankshaft, 8 mm | 1 | 56. | 96701600 | Washer, Ø 8.4x14.4x2.0 | 4 |
| 20. | 53210470 | Support Ring, Ø 13 | 3 | | | (ET1308S34) | | 57. | 50200074 | Pump Foot | 2 |
| 21. | 90360400 | O-ring, 25.12x1.78 | 3 | | 60028535 | Crankshaft, 9 mm | 1 | 58.* | 101162 | Kit, ADTR, 1/4"-F, SS, W/Seal | 1 |
| 22. | 90260100 | Packing, Ø 13, LP | 3 | | | (ET1309S34) | | 59.* | 101157 | Kit, ADTR, 1/4"-M, SS, W/Seal | 1 |
| 23. | 93738000 | Washer, Ø17.5x23x1.5 | 1 | | 60028335 | Crankshaft, 10 mm | 1 | 60.* | 101158 | Kit, ADTR, 3/8"-K, SS, W/Seal | 1 |
| 24. | 98210050 | Plug, 3/8"x13 | 1 | | | (E1310S34) | | 61.* | K423 | Kit, Tapped Valve Plate | 1 |
| 25. | 96751400 | Washer | 1 | | 60028435 | Crankshaft, 11 mm | 1 | | W/ Valve Spacer & Seals | | |
| 26. | 98218700 | Plug, 1/2" BSPx10 | 1 | | | (ET1311S34) | | | | | |

* Optional Parts

** 53150001 Oil Level Indicator Assembled W/O Screws and O-ring

REPAIR KITS

| KIT NO. | K309 | K311 | Ø 13 | |
|---------------------------|----------------------------------|------|--------------------|----------------------------|
| | | | K318 | K319 |
| ITEM NO'S INCLUDED IN KIT | 2, 3, 4, 5, 6, 13, 14, (7), (15) | 31 | 17, 18, 19, 21, 22 | 17, 19, 19, 20, 21, 22, 50 |
| NUMBER OF ASSY'S IN KIT | 6 | 3 | 3 | 1 |
| NO. OF CYLINDERS | 3 | 3 | 3 | 1 |
| KIT SERVICES | | | | |

TORQUE SPECS*

| Position | Ft.-Lbs. | Nm. |
|----------|----------|-----|
| 8 | 8.9 | 12 |
| 10 | 4.4 | 6 |
| 16 | 8.9 | 12 |
| 24** | 30 | 40 |
| 26 | 30 | 40 |
| 36 | 7.4 | 10 |
| 47 | 14.8 | 20 |
| 49** | 9.6 | 13 |

*Decrease torque by 20% if threads are lubricated.
**Use Loctite 542 Red

DIMENSIONS

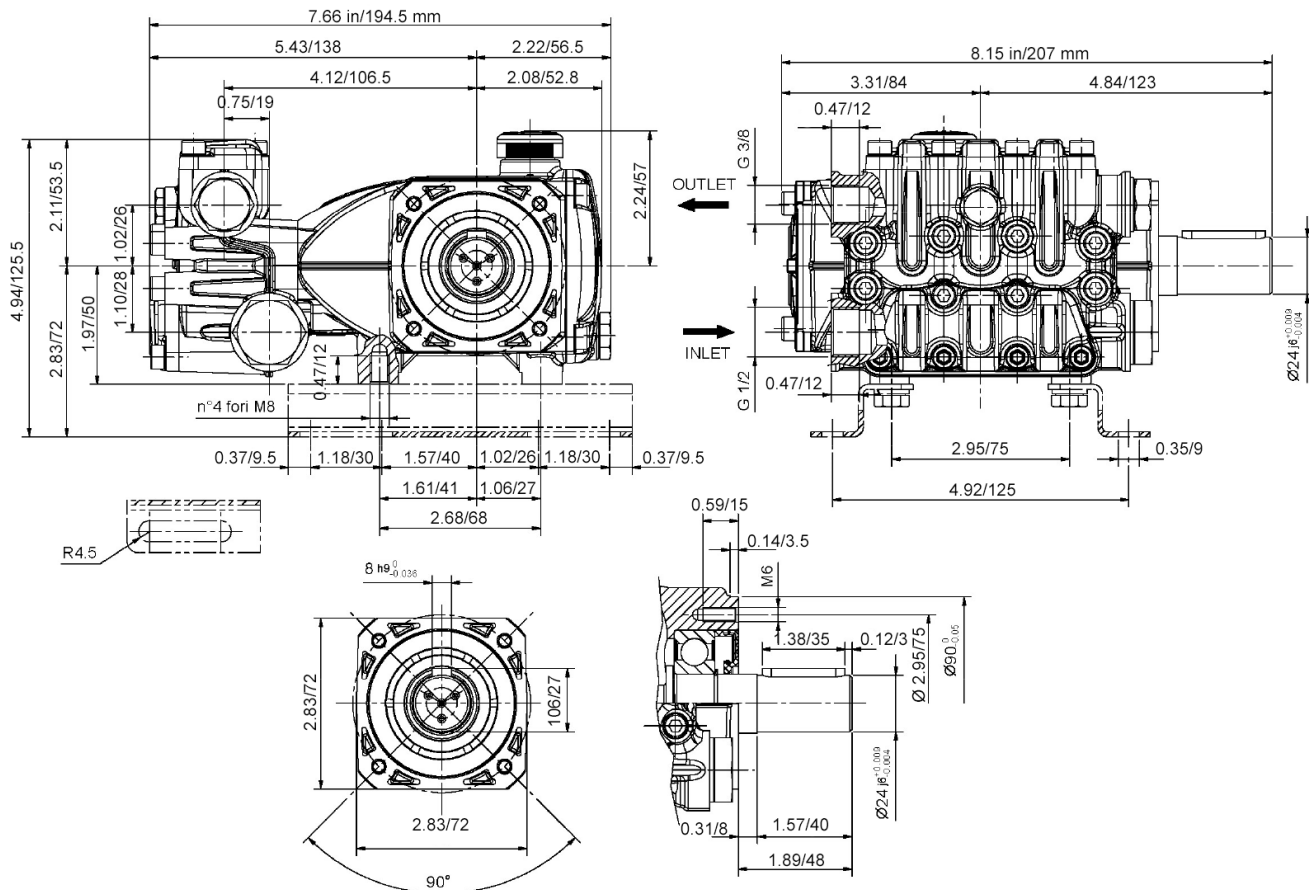

WARNING: High Pressure Systems require a primary pressure regulating device (i.e. regulator, unloader) and a secondary pressure relief device (i.e. pop-off valve, relief valve). Failure to install such relief devices properly could result in personal injury or damage to pump or property. GP does not assume any liability or responsibility for the operation of the user's high pressure system.

