

FEATURES

- Features patented “high tech” packings:
 - dynamic low-pressure seal retainer
 - superior low-pressure seal
 - innovative intermediate ring
 - superior high-pressure seal
- Ceramic plungers
- Patent-pending inlet/outlet valve cage
- Stainless Steel manifold (316 SS)
- Nickel-plated crankcase
- Heavy-duty tapered roller bearings
- Specifically designed to handle Reverse Osmosis, Desalination, Chemical Injection, Deionized Water, Pharmaceuticals and Aggressive Enviornments



SPECIFICATIONS

Pump Model	ESS2010SS	ESS2012SS	ESS2212SS	ESS2213SS
Maximum Volume	4.0 GPM	4.75 GPM	5.50 GPM	5.50 GPM
Maximum Pressure	3,000 PSI			
Maximum RPM	1750 RPM	1750 RPM	1750 RPM	1450 RPM
Horsepower	8.2 EBHP	9.8 EBHP	11.3 EBHP	11.3 EBHP
Maximum Inlet Pressure	125 PSI			
Minimum Inlet Vacuum	3 ft. water (2.6 in. Hg)			
Maximum Fluid Temperature	185°F			
Bore (in / mm)	.787 in./20 mm	.787 in./20 mm	.866 in./22 mm	.866 in./22 mm
Stroke (in / mm)	.394 in./10 mm	.472 in./12 mm	.472 in./12 mm	.551 in./14 mm
Oil Capacity	22 oz.			
Inlet Port Thread	1/2" - 14 BSP-F			
Discharge Port Thread	3/8" - 19 BSP-F			
Shaft Diameter	.945 in./24 mm			
Weight	22.0 lbs.			
Dimensions - Nominal	10.4" x 8.8" x 5.4"			

TRIPLEX

TRIPLEX

Instructions and Recommendations for the Installation of **59 Series Pumps**

The high-temperature pumps of the ESS series have been designed for use in applications where the water must be pre-heated, such as in carwash, food and pharmaceutical industries.

Maximum temperature of the water through the pump is 185°F (85°C).

In order to obtain maximum performance in terms of duration of seals and valves, it is necessary to respect a few simple rules, as follows:

1) **In order to avoid damage caused by cavitation, the pump must be pressure fed.**

The higher the inlet pressure, the longer the life of the wet end of the pump.

When working at 185°F (85°C), the minimum feed pressure - measured directly in the inlet port of the pump when it is working - is 45 psi (3 bar).

The minimum feed pressure according to the different temperatures are:

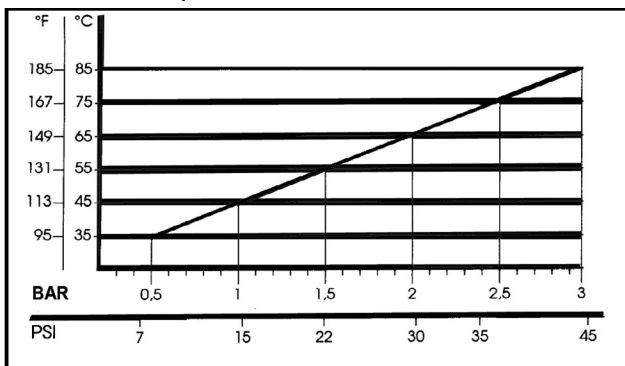

Naturally, if the application allows for feeding the pump with 45 psi (3 bar) even at low temperatures (for example: 115°F/45°C the life of the wet end of the pump will be even longer.

2) **The plumbing which feeds the pump must be of a diameter at least equal to the inlet port.**

Also, follow the suggestions below:

a) Make the plumbing as short and straight as possible, preferably in an upward direction to facilitate the expulsion of eventual air bubbles naturally if compatible with the requirements of the system.

b) It is always useful to put a filter at the inlet with capacity of 4 to 5 times the flow of

the pump, for example for a 4 gpm (15 l/min) pump, put a filter from 16 to 20 gpm (60-75 l/min). The mesh size suitable for this application is 0.016" (.4 mm).

c) It is extremely important to put a pressure switch on the suction port of the pump, and in any case downstream from the filter, so that it can stop the pump should the feed pressure drop by 20% due to the filter clogging or failure of the feed pump, etc.

3) **Change of oil**

We recommend the **first oil change after the first 50 hours**, with the **pump stopped** and the **oil still warm**.

This change is not recommended because the oil has lost its properties, but rather to eliminate the impurities that have gotten into the oil during the running-in phase. If these impurities are not removed, but are allowed to remain in the oil, they **may cause premature wear** to the moving parts and the oil seals. **After this initial change, the oil can then be changed every three months or 300 hours of operation thereafter.**

Please note: If the pump works in conditions with high humidity and with sharp temperature changes, it is possible that condensation will appear inside the crankcase, which mixing with the oil can change its properties. This is easy to see because the oil changes to a white, milky color.

If the pump does not have excessive water leaking from the packings, and the oil becomes milky, the oil has to be changed more frequently. The percentage of water in the oil must not exceed 20%.

Use oil per the following chart:

BRAND	TYPE
BP	ENERGOL HLP 220
MOBIL	DTE OIL BB
TOTAL	CORTIS 220

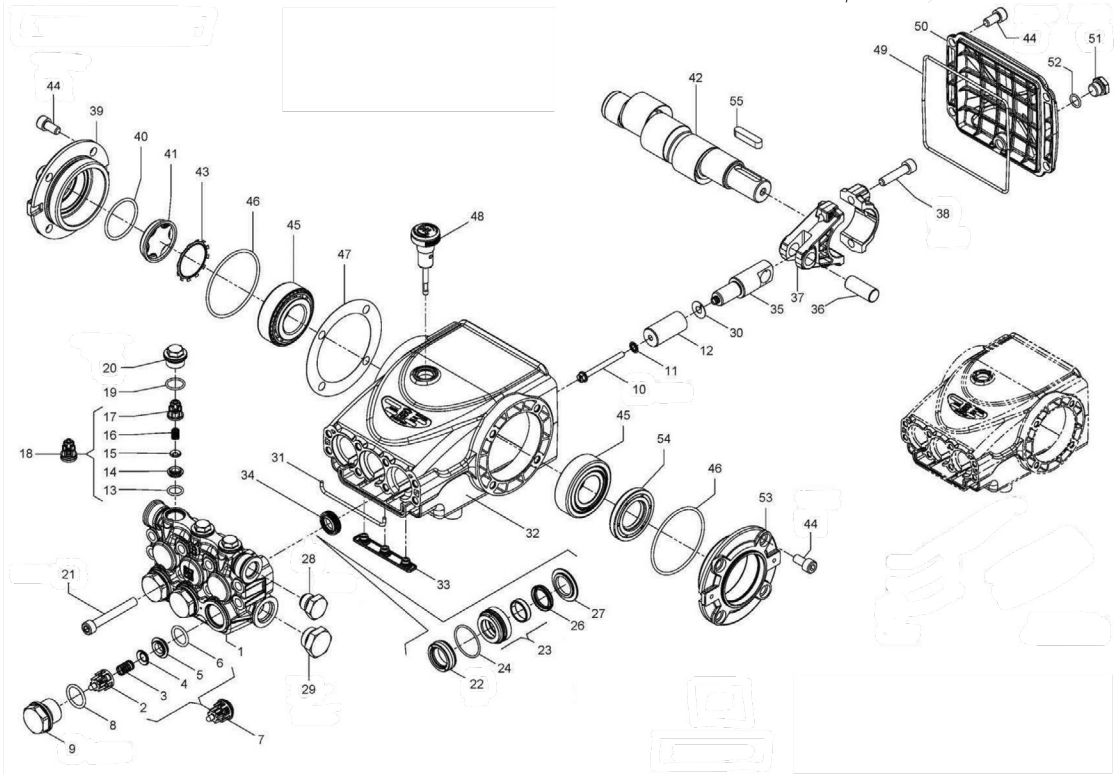

PARTS LIST

ITEM	PART NO.	DESCRIPTION	QTY	ITEM	PART NO.	DESCRIPTION	QTY	ITEM	PART NO.	DESCRIPTION	QTY
1.	59122036	Manifold, Ø 20	1	22.	90226000	Packing, Ø20x30x10, H.P.	3	42.	59020135	Crankshaft (ESS2213SS)	1
	59122136	Manifold, Ø 22	1		90231200	Packing, Ø22x30x10, H.P	3		59020235	Crankshaft (ESS2012SS, ESS2212SS)	1
2.	36202551	Valve Cage	3	23.	59606401	Head Ring, Ø 20	3		59020335	Crankshaft (ESS2010SS)	1
3.	94737600	Spring, Ø 9.4x14.8	3	24.	59606501	Head Ring, Ø 22x25	3	43.	90075600	Retaining Clip	1
4.	36200176	Valve, Spherical	3	26.	90225000	Packing, Ø 20x26.15, LP	3	44.	99303800	Screw, M8x16	12
5.	36200366	Valve Seat, Inlet	3		90230000	Packing, Ø 22x26.15, LP	3	45.	640047	Tapered Roller Bearing	2
6.	701115	O-ring, Ø17.13v2.62	3	27.	59211556	Packing, Ø 20	3	46.	701147	O-ring, Ø 67.95x2.62	2
7.	36713001	Valve Assembly	3	28.	59211656	Packing, Ø 22	3	47.	97567800	Shim, 0.3 mm	1
8.	701002	O-ring, Ø20.24x2.62	3	29.	98210066	Plug, 3/8"x13	1	48.	97568000	Shim, 0.1 mm	1
9.	98222900	Valve Cap, M24x1.5x17	3	30.	96738000	Plug, G 1/2"x10	1	49.	98210500	Oil Dipstick	1
10.	99169000	Plunger Bolt, M5x55	3	31.	96699000	Washer, Ø 7.5x23x0.5	3	50.	90392200	O-ring, Ø133.02x2.62	1
11.	96690500	Washer, Ø 5x11.5x0.4	3	32.	59211082	Gasket, Ø 3x103	1	51.	59160122	Rear Cover	1
12.	59040009	Plunger, Ø 20x42	3	33.	59010122	Crankcase	1	52.	98204250	Plug, 3/8"x9	1
13.	59040109	Plunger, Ø 22x42	3	34.	58210451	Drip Cover	1	53.	701013	O-ring, Ø 10.82x1.78	1
14.	90367400	O-ring, Ø 12.00x2.00	3	35.	90156550	Oil Seal, Ø 15x24x5.7	3	54.	59150122	Side Cover	1
15.	53211166	Outlet Valve Seat	3	36.	59050066	Piston Guide	3	55.	90164800	Oil Seal, Ø 30x55x7	1
16.	36211276	Outlet Valve Poppet	3	37.	97739900	Piston Pin, Ø 14x34	3		91489200	Key	1
17.	94733300	Spring, Ø 6.2x10.4	3	38.	59030001	Connecting Rod	6				
18.	36211151	Outlet Valve Cage Guide	3	39.	99309900	Connecting Rod Screw	1				
19.	36724501	Complete Outlet Valve	3	40.	59150222	Crankcase Cover, Side	1				
20.	701016	O-ring, Ø 15.6x1.78	3	41.	90387700	O-ring, Ø 39.34x2.62	1				
21.	98213720	Plug, M18x1.5x10	3		70211801	Sight Glass	1				
	99317600	Screw, M8x60	8								

REPAIR KITS

KIT NO.	K341	K334	K349	K336	K271	20 mm		22 mm	
						K350	K351	K352	K353
ITEM NO'S INCLUDED IN KIT	2, 3, 4, 5, 6, (7)	13, 14, 15, 16, 17, (18)	8, 9	19, 20	34	22, 24, 26	22, 23, 24, 26, 27	22, 24, 26	22, 23, 24, 25, 26, 27
NUMBER OF PIECES IN KIT	3	3	3	3	3	3	1	3	1

TORQUE SPECS*

Position	Ft.-Lbs.	Nm.
9	95.88	130
10	4.43	6
20	44.25	60
21	14.75	20
28*	29.50	40
29*	29.50	40
38	14.75	20
44	14.75	20
51	14.75	20

*Decrease torque by 20% if threads are lubricated.

DIMENSIONS

