

EM Series 83

Triplex Plunger Pump, Electric Flange

FEATURES

- High-resistance coated manifold
- New generation seal package
- New dust protection chamber
- Solid ceramic plungers
- New oversized plunger guide
- New optimized inlet and outlet valves
- New oil seal
- Flanged for direct couple to electric motors (56C)
- Available in left-handed (L) version

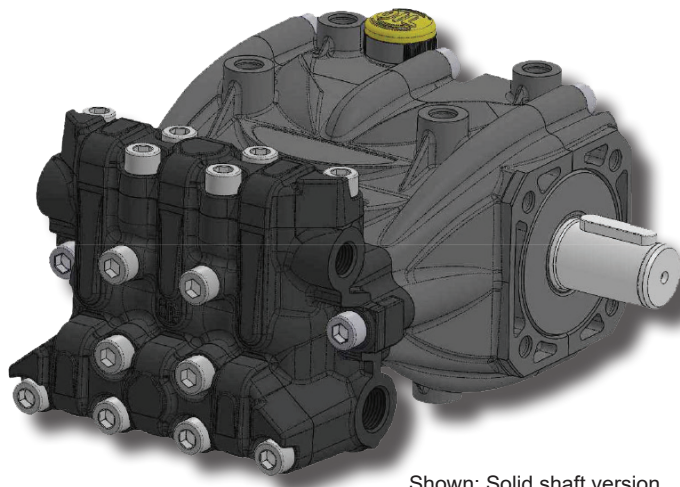

Shown: Solid shaft version

SPECIFICATIONS

Pump Model	EM12048E(L)	EM12078E(L)	EM12095E(L)	EM12120E(L)
Maximum Volume	0.66 GPM / 1.32 GPM	1.19 GPM / 2.11 GPM	1.45 GPM / 2.64 GPM	1.85 GPM / 3.43 GPM
Maximum Discharge Pressure	3,000 PSI			
Horsepower	1.4 EBHP / 2.7 EBHP	2.5 EBHP / 4.4 EBHP	3.0 EBHP / 5.5 EBHP	3.8 EBHP / 7.1 EBHP
Maximum Pump Speed	1750 RPM / 3400 RPM			
Maximum Inlet Pressure	125 PSI			
Plunger Bore (in / mm)	.472 in. / 12 mm			
Plunger Stroke (in / mm)	.189 in./4.8 mm	.307 in./7.8 mm	.374 in./9.5 mm	.472 in./12.0 mm
Oil Capacity	4.7 oz.			
Maximum Fluid Temperature	140° F*			
Inlet Port Thread	1/4" BSPP-F			
Discharge Port Thread	1/8" BSPP-F			
Shaft Diameter	5/8" Hollow			
Weight	7.7 lbs.			
Dimensions - Nominal	6.2"W x 5.5"H x 6.4"L			

*140°F permissible for short periods, Maximum seal life obtained at 104°F Max. Exceeding the maximum rating may be allowable under certain conditions; contact your GP Representative.

STANDARD VERSION

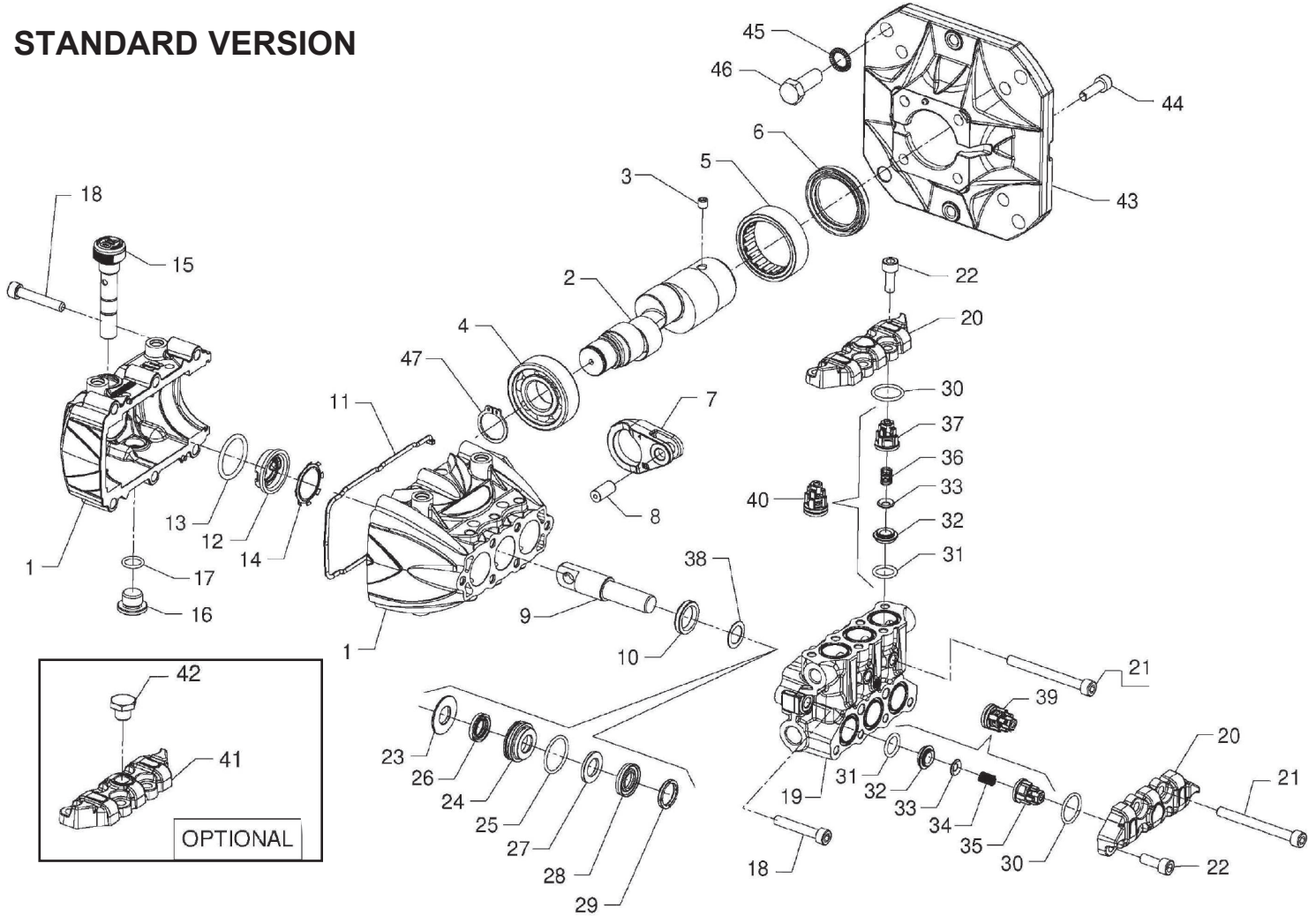

PARTS LIST

ITEM	PART NO.	DESCRIPTION	QTY	ITEM	PART NO.	DESCRIPTION	QTY	ITEM	PART NO.	DESCRIPTION	QTY
1.	83010201	Crankcase	1	15.	98204900	Oil Dipstick	1	32.	36211366	Inlet Valve Seat	6
2.	83021065	Crankshaft (EM12048E)	1	16.	98204150	Screw, G 1/4"x9	1	33.	36211276	Spherical Inlet Valve	6
	83020565	Crankshaft (EM12078E)	1	17.	701013	O-ring, Ø 10.82x1.78	1	34.	94732600	Spring, Inlet, 6.0x12.0	3
	83020665	Crankshaft (EM12095E)	1	18.	99192600	Screw, M6x35	8	35.	36211951	Valve Guide, Inlet	3
	83020165	Crankshaft (EM12120E)	1	19.	83120013	Manifold, Ø12	1	36.	94733300	Spring, Outlet, 6.7x10.8	3
3.	99179000	Screw, M6x06	1	20.	83210013	Valve Cover	2	37.	36211151	Outlet Valve Guide	3
4.	91822100	Ball Bearing	1	21.	99199000	Screw, M6x60	4	38.	83210851	Ring	3
5.	91846000	Roller Bushing	1	22.	99185400	Screw, M6x16	10	39.	36722401	Inlet Valve Assembly	3
6.	90166000	Seal, Crankshaft, Ø35.0x47.0x6.0	1	23.	83210370	Seal Ring, Ø 12	3	40.	36719301	Outlet Valve Assembly	3
7.	83030022	Connecting Rod	3	24.	83210270	Gasket Support, Ø 12	3	41.	83210113	Valve Cover, G1/8 opt.	1
8.	97730500	Pin, Ø8.0x17.0	3	25.	90360000	O-ring, Ø 21.95x1.78	3	42.	98196800	Plug, G1/8 opt.	1
9.	83040101	Plunger Assy., Ø12	3	26.	90258950	Seal Ring, Ø 12.0x18.5x4.5	3	43.	10098422	Flange, Electric, 56C	1
10.	90158000	Seal, Oil, Ø6.0x22.0x4.0	3	27.	90507080	Anti-extrusion Ring	3	44.	99188400	Screw M6x20	4
11.	83210747	Gasket, Crankcase	1	28.	90258900	Seal Ring, Ø 2.0x21.0x4.2	3	45.	96710400	Washer Ø 10.5x16.0x1.0	4
12.	53210851	Oil Level Sight Glass	1	29.	83100051	Head Ring, Ø 12	3	46.	99334500	Screw, 3/8"-16x1"	4
13.	90385900	O-ring, Ø25.07x2.62	1	30.	90359500	O-ring, Ø 17.17x1.78	6	47.	90060500	Anti-extrusion Ring	1
14.	90067100	Stop Ring	1	31.	90367400	O-ring, Ø 12.00x2.00	6				

REPAIR KITS

TORQUE SPECS*

STANDARD

KIT NO.	K309	K400	K401	K402
ITEM NO'S INCLUDED IN KIT	31, 32, 33, 34, 35, 36, 37 (39, 40)	10	25, 26, 27, 28, 29	23, 24, 25, 26, 27, 28, 29
NUMBER OF PIECES	3	3	3	1

STANDARD

Position	Ft.-Lbs.	Nm.
16	13.3	18
18	9.8	12
21	9.8	12
22	9.8	12
42	9.8	12
44	7.4	10

DIMENSIONS

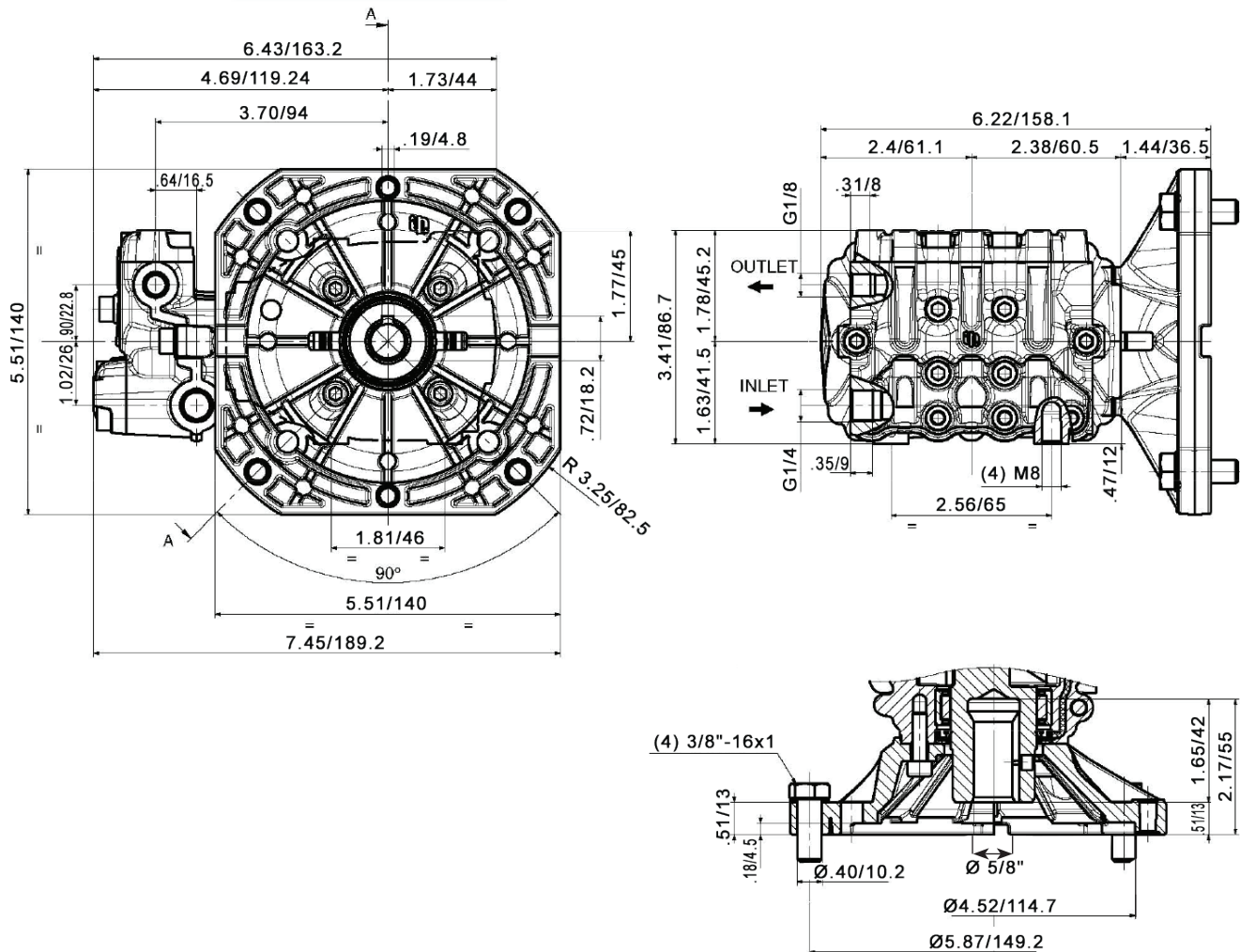

WARNING: High Pressure Systems require a primary pressure regulating device (i.e. regulator, unloader) and a secondary pressure relief device (i.e. pop-off valve, relief valve). Failure to install such relief devices properly could result in personal injury or damage to pump or property. GP does not assume any liability or responsibility for the operation of the user's high pressure system.

Instructions and Recommendations for the Installation of

EM Series Pumps

THIS MANUAL CONTAINS THE INSTRUCTIONS REQUIRED TO INSTALL GENERAL PUMP PUMPS AND PROVIDES THE INSTALLATION ENGINEER WITH THE NECESSARY INFORMATION ON THEIR USE AND MAINTENANCE. IT THUS FORMS AN INTEGRAL PART OF THE INSTRUCTIONS AND SHOULD BE READ CAREFULLY BEFORE PROCEEDING TO PERFORM ANY OPERATIONS, AND KEPT WITH CARE.

FOLLOW THE INSTRUCTIONS SCRUPULOUSLY IN ORDER TO ENSURE SAFE AND EFFICIENT OPERATION. FAILURE TO DO SO MAY CAUSE FAULTS TO OCCUR PREMATURELY AND CREATE HAZARDS, AS WELL AS MAKING THE GUARANTEE NULL AND VOID.

1. GENERAL INFORMATION

1.1 The installer is responsible for passing this information on to the end user to ensure that the machine on which the pump is used is used properly. General Pump declines all liability for any damage caused by negligence or failure to respect the rules contained in this manual.

1.2 The STANDARD pumps work with clean, soft water at a maximum temperature of 104° F (40° C) and, for short periods only, up to 140°F (60°C). In the latter case, call GP customer service to determine the specifications required according to the type of system installed.

Emperor Series pumps are specifically designed to operate with soft and clean water up to a temperature of 185° F (85° C) in compliance with the conditions indicated on the chart on the last page. The SS series pumps are specially designed to work with salty water, demineralized water up to a temperature of 185°F (85°C) and other aggressive solutions; for the latter, call the GP customer Service to assess compatibility and the specifications required according to the type of application. The performance indicated in the catalog refers to the maximum performance provided by the pump. Irrespective of the power used, the pressure and maximum number of revolutions indicated in the catalog cannot be exceeded unless expressly authorized by the GP customer service.

1.3 - Improper use of pumps and high-pressure systems and failure to respect installation and maintenance regulations may cause serious injury to persons and/or damage to things.

No reasonably applicable safety precaution must be omitted by the installation engineer or the operator. Any person responsible for assembling or using high-pressure systems must have the competence required to do so, be familiar with the characteristics of the components he is about to assemble/use and adopt all necessary precautions required to guarantee maximum safety under all operating conditions.

1.4 - Considering that the pump is incorporated in a complete system, its installation and use should be suitable for the type of system and conform to the safety regulations in force in the country where it is to be used.

1.5 - Before using the pump, make sure that the system in which it is incorporated has been declared compliant with the provisions laid down by the applicable Directives and/or standards.

1.6 - Before installing and using the pump received, we recommend you check its condition and that its ratings correspond to those required. If they do not, avoid starting the pump and contact the GP customer Service for instructions.

1.7 - The pump must be assembled and installed by qualified staff, with the necessary mechanical and technical skills, following the user and safety instructions given in this manual and the manual provided with the pump.

1.8 - High-pressure system components, particularly those of systems that run mainly outdoors, must be adequately protected against the rain, frost and heat.



A suitably-calibrated overpressure valve must be installed, as well as the pressure regulating valve, must be installed on the high-pressure line.



The high-pressure hoses must be correctly sized for the system's maximum working pressure and used exclusively within the working pressure range indicated by the pipe manufacturer and marked on the pipe itself.



The ends of the high-pressure hoses must be sheathed and secured to a solid structure, so as to avoid the risk of whiplash if the connections burst or break.



The pump transmission systems (joints, pulleys, belts, rotary shafts), must be suitably covered by a protective case.

Instructions and Recommendations for the Installation of EM Series Pumps



In relation to the application, use and environmental conditions, during the operation the outer surfaces of the pump may reach high temperatures.



If in doubt, call the GP customer service department.

2 - INSTALLATION

- 2.1 - The pump should be installed in a horizontal position using the supporting feet or coupled directly to the motor using the original flange provided.
- 2.2 - The base must be flat and rigid so as to avoid bending and misalignments along the pump/motor coupling axis.
- 2.3 - The pump/motor assembly cannot be fixed rigidly to the frame or base, anti-vibration elements must be set in between.
- 2.4 - Avoid installing and using the pumps near heat sources and/or in environments where condensation may form as this affects the effectiveness of the lubricant contained in the pump.
- 2.5 - Make sure that the pump never operates dry even for short periods by installing safety devices on the system.
- 2.6 - For pumps with a built-in regulating valve or if the plant system has the pressure regulating valve outlet (BYPASS) connected directly to the feed inlet (IN) of the pump, the pump must not be operated in BYPASS mode for more than 3 minutes, otherwise there will be a risk of damage to the seals and valves caused by overheating. For special applications, contact GP customer service.

3 - FEED LINE

To ensure the pump works to its full potential, the feed line must have the following characteristics:

- 3.1 - An inside diameter at least as large as the (IN) inlet on the pump manifold; along the pipe avoid fitting 90° elbows, connections with other pipes, chokes, "T" connections, siphons, areas where air bubbles may stagnate and cause head losses and cavitation.
- 3.2 - The lay-out must be such as to ensure, under all working conditions, a positive head of between min. 0.20 m (0.02 bars) and max. 80 m (8 bar) measured at the pump feed inlet; this minimum value is valid for cold water having a temperature of up to 20°C, for higher temperatures, see the graph on the last page. The pumps can also work at a lower supply pressure, under certain operating conditions authorized by GP customer service
- 3.3 - It must be completely airtight and designed in such a way that its seal is guaranteed to last in time.
- 3.4 - It must be equipped with a filter of a suitable size, according to the capacity of the pump, and with a filtering degree of min. 300 µm; the filter must be positioned as close as possible to the pump feed attachment. NOTE: Even if the water to be used is clean, the filter must be installed to prevent foreign bodies present in the plant system such as swarf, welding slag or limestone scaling from entering the pump.
- 3.5 - Flexible piping should be used in the section closest to the pump so as to prevent forced connections and the transmission of vibrations.
- 3.6 - It must be designed in such a way as to avoid the pump emptying even only partially when it comes to a halt.

4 - DELIVERY LINE

The following rules should be respected in designing the DELIVERY line:

- 4.1 - The inside diameter of the piping must be correctly sized according to the maximum pressure and capacity so as to ensure the appropriate speed of the fluid and to limit head losses.
- 4.2 - The first section of piping connected to the pump must be flexible, so as to avoid forced connections and to isolate the vibrations produced by the pump from the rest of the plant system.
- 4.3 - Use should be made of pressure gauges capable of withstanding the pulsating loads typical of piston pumps, installed in such a way as to measure the pressure directly at the pump manifold.

Instructions and Recommendations for the Installation of EM Series Pumps

4.4 - In the design phase, consideration should be given to the head losses on the line, which result in a drop in working pressure with respect to the pressure measured at the pump.

4.5 - A suitably sized pulsation damper should be installed for applications in which the pulsations produced by the pump on the delivery line have an undesired or detrimental effect.



Use high-pressure pipes and fittings suited to the working pressures that may arise under all operating conditions. Therefore we recommend to take precautions to avoid contact with hot parts.



Install a suitably calibrated overpressure valve, as well as the pressure regulating valve.

5 - MAINTENANCE

5.1 - System maintenance work should be done within the time intervals laid down by the system manufacturer, who is responsible for the entire assembly in accordance with the law.

5.2 - Correct maintenance prolongs the life of the pump and maintains its maximum performance in time.

5.3 - All maintenance work should be done by specialized, authorized staff.

5.4 - The pump and its components are to be assembled and disassembled exclusively by authorized staff, using equipment suited to the purpose so as to avoid damaging components that could put their safety at risk.

5.5 - When it is to be scrapped, we recommend you take the pump to an authorized waste disposal center or call GP customer service.

5.6 - Scheduled maintenance:

After the first 50 hours	Every 500 hours	Every 1000 hours (mean period: should be reduced for harsh operating conditions)
Oil change	Oil change	Checking/replacement: Valve assemblies, pumping seals

6 - GUARANTEE CONDITIONS

6.1 – The guarantee period and conditions are indicated in the purchase agreement.

6.2 – The guarantee will, in any case, be considered null and void if the pump is used for improper purposes, coupled with motors having a power higher than those indicated, used at pressures or speeds higher than those indicated, repaired with non-original spare parts or if it is damaged as a result of a failure to following the instructions given in this manual.

7 - START-UP

Replace the RED transport cap with the cap with a built-in dipstick provided.

7.1 - Check the oil level through the window or using the dipstick and, if necessary, top it up.

7.2 - Make sure that all fittings are securely tightened and that the pump feed is open.

7.3 - To expel the air present in the pump and make it easier to fill, we recommend you detach the delivery pipe from the pump or keep the appliance/s open without any nozzles fitted.

7.4 - Start the pump for 5/10 seconds until the liquid flows out smoothly from the delivery pipe or appliances; if this does not happen, stop the pump and repeat the operation after a 10-second pause.

7.5 - Complete the connections and/or install the nozzles.

7.6 - All General Pump pumps are tried and tested prior to shipment, the installation engineer is, however, obliged to test the complete system for an adequate time to check for leaks, overheating, deterioration in performance or calibration, etc.



Calibrate or regulate the valves; to prevent tampering, apply lead seals where possible, or paint the regulating registers so that any tampering can be readily detected.

Instructions and Recommendations for the Installation of EM Series Pumps

8 - TROUBLESHOOTING GUIDE

At start-up, the pump makes no noise	<ul style="list-style-type: none"> The pump is not primed and is operating dry, without lubricant The water supply is off The valves are blocked The delivery line is closed and does not let the air flow out of the pump
The hoses pulsate in an irregular fashion	<ul style="list-style-type: none"> There is insufficient air suction and/or supply Bends, elbows, fittings on the feed line are slowing down the flow of the liquid. The feed filter is dirty or too small The booster pump, if installed, is providing an insufficient pressure and/or capacity The pump is not primed due to an insufficient head, the delivery pipe closing during priming and/or a valve sticking Worn pressure valves and/or seals and/or transmission problems The pressure regulating valves are not working properly
The pump does not give the rated capacity and makes excessive noise	<ul style="list-style-type: none"> There is an insufficient supply and/or the number of revolutions is less than the rated value Excessive leaking from the pressure regulating valve and/or the pressure seals Worn valves Cavitation due to undersized feed pipes and/or filter, insufficient capacity, high water temperature, clogged filter
The pressure supplied by the pump is insufficient	<ul style="list-style-type: none"> The appliance (nozzle) is too large or is worn Excessive leaking from the pressure seals The pressure regulating valve is not working properly and/or the valves are worn
The pump overheats	<ul style="list-style-type: none"> The pressure and/or the number of revolutions is higher than the rated value. The oil in the sump of the pump is not at the required level or is not of the recommended type. The belt is too tight, the joint or the transmission is not aligned.

MINIMUM FEED PRESSURE CHART

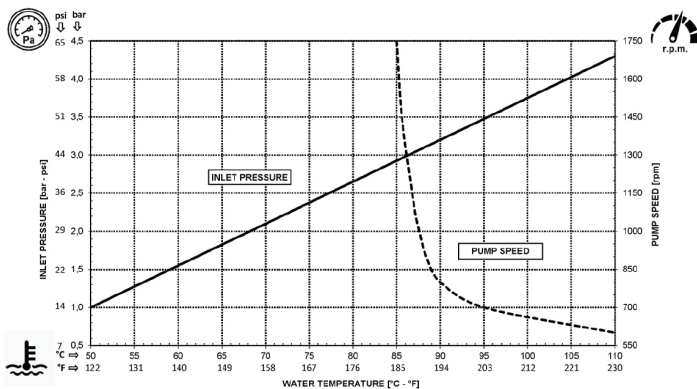

CHART OF COMPATIBLE OILS SAE15W40

General Pump	Series 100
BP	VISCO 2000
CASTROL	CWX
MOBIL	SUPER
SHELL	HELIX SUPER
TOTAL	QUARTZ 4000-5000

