

# DHR50100/50150

## Hose Reels



### SPECIFICATIONS

PART NUMBER	DHR50100	DHR50150
3/8" Hose Capacity	100 ft.	150 ft.
Swivel Pressure Rating	5000 PSI	
Inlet	3/8" NPT-M	
Outlet	3/8" NPT-F	
Max. Temp	300° F	

### FEATURES / BENEFITS

- Direct hand-crank rewind with locking pin
- Durable powdercoat finish
- Solid steel construction
- Full flow swivel steel joint

### DIMENSIONS (in/mm)

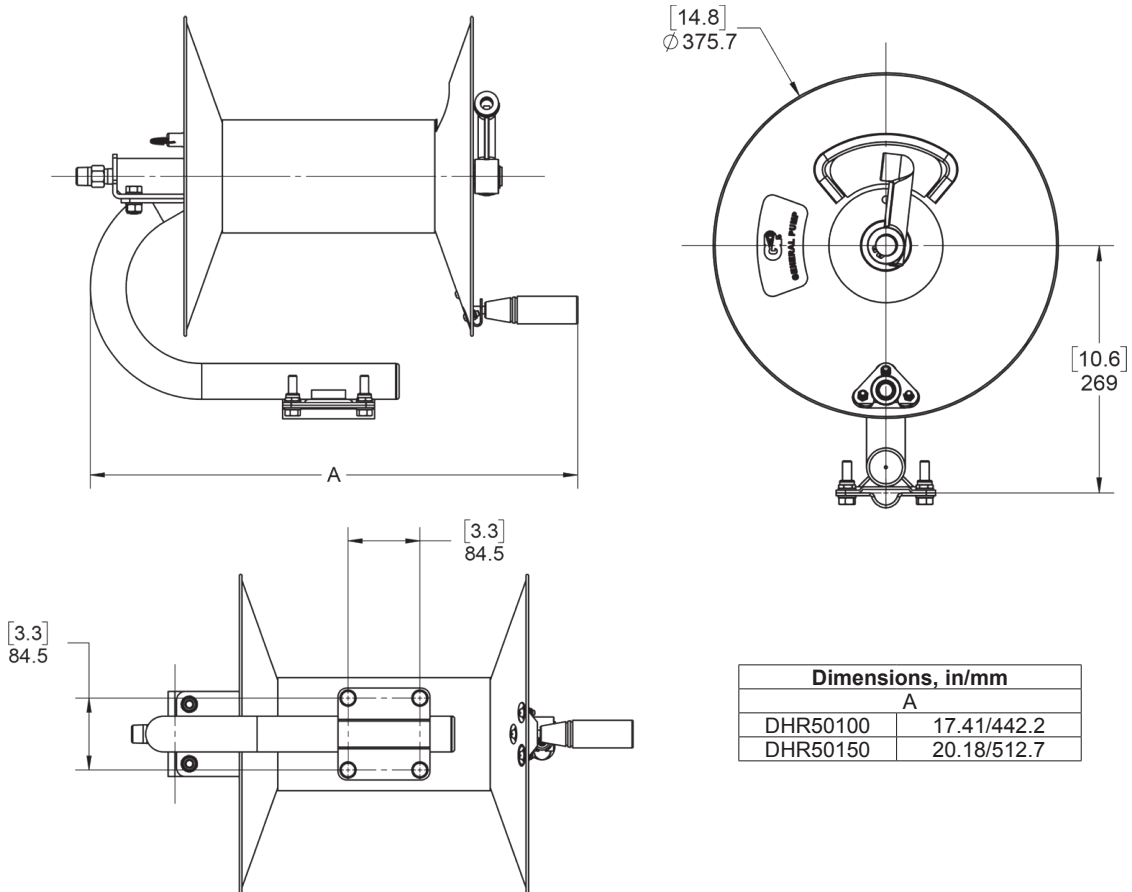

General Pump  
is a member of  
the Interpump Group



### PARTS LIST

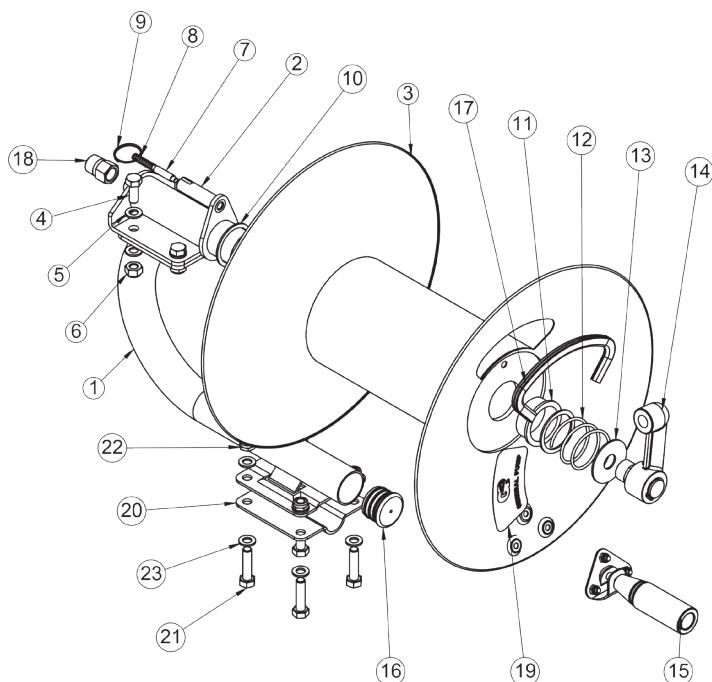

Item No.	Part No.	Description	Qty.
1	2103355	Base, 100'	1
1	2103357	Base, 150'	1
2	2103356	Arm, 100'	1
2	2103358	Arm, 150'	1
3	2540011	Assy, Flange, 100'	1
3	2103359	Assy, Flange, 150'	1
4	2200118	Bolt, HHCS, M10 x 25	4
5	2203413	Washer, Flat, M10	8
6	2203017	Nut, M10, Nylok, SST	4
7	2540001	Pin, Lock	1
8	2720004	Spring	1
9	2200032	Ring	1
10	2203403	Washer	2
11	2530025	Bushing	2
12	2720010	Spring	1
13	2203416	Washer, Swivel	1
14	2103130	Swivel, Hose Reel, Forged	1
15	100056	Handle, Assy	1
16	2660385	Plug	1
17	2702005	Guard, Hose	1
18	2530112	Fitting, 1/2 NPT-M x 3/8 NPT-F	1
19	2400004	Decal, GP	1
20	2200014	Bracket, Clamp	1
21	2200016	Bolt, HHCS, M10 x 35	4
22	2200019	Nut, Nylok, M10	4
23	2200008	Washer, Flat, M10	8
2100278		Swivel Repair Kit	

### ASSEMBLY INSTRUCTIONS

1. Connect the handle to the flange. Nuts go on handle side of flange.
2. Use (4) 3/8" or 10 mm bolts when securing the hose reel to ceiling or wall.
3. Use the provided nuts, bolts and mounting bracket when securing hose reel to a cart.
4. Use thread sealant (not provided) on inlet threads and on outlet hose (not provided).
5. Attach hose from high pressure pump outlet to hose reel inlet.
6. Attach hose reel hose to swivel on hose reel
7. The hose reel is ready for operation.

### SAFETY PRECAUTIONS

1. Make sure incoming pressure does not exceed the rated pressure.
2. Use proper eye protection when assembling and using the hose reel.
3. Assemble the hose reel on a clean workbench free of debris and moisture.
4. Use soap and water when checking for air leaks.
5. Keep children away from work area.

#### **WARNING!**

*Exposure of skin directly to pressurized air or fluids could result in severe bodily injury!*