

**GENERAL PUMP** *A member of the Interpump Group*

# 2560001 Multi-Nozzle Holder

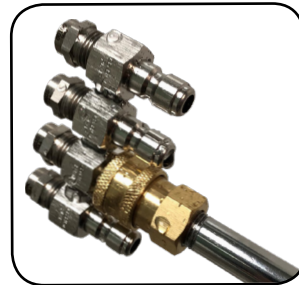

Above: 2560001 attached to a wand, holding 4 - 1/4" nozzles (wand and nozzles sold separately).

This handy tool made from 304 Stainless Steel, allows you to very quickly switch between four different nozzles on one spray gun wand. It accepts any 1/4" NPT-M thread spray nozzles and turns each one into a quick-connect tip. Works great for changing between foam and water, reaching multiple height levels, or altering the intensity of the spray without having to carry around several individual nozzles!

Nozzles not included.

## DIMENSIONS

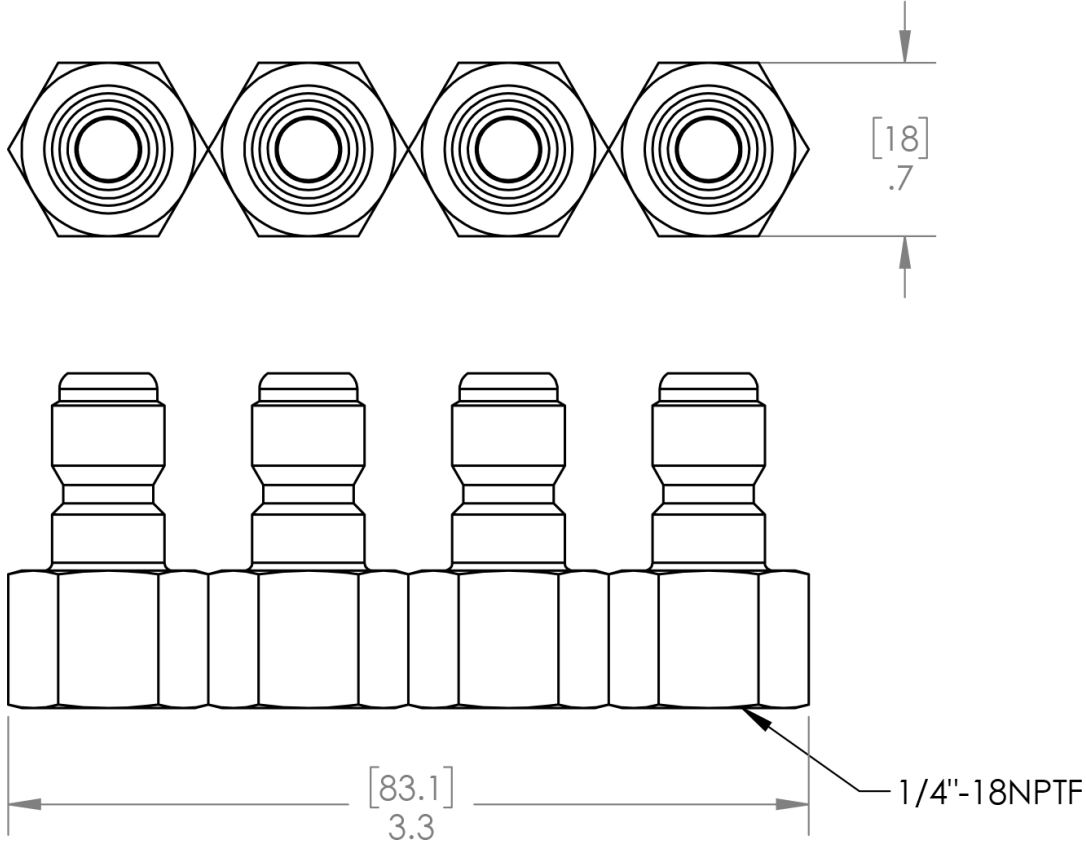

General Pump is a member of the Interpump Group



Ref 301032 Rev B  
03-21



# Multi-Nozzle Holder

**CHOOSING THE CORRECT SIZE GP NOZZLE** *(not included with nozzle holder)*

1. Find Your Nozzle Pressure (PSI) in the gold shaded area.
2. Find your Gallons Per Minute (GPM) in the blue shaded area.
3. In the blue square that your PSI and GPM intersect, follow it to the far left Nozzle Size green-shaded area.
4. This will be the Nozzle Size you need.

Nozzle Size	40 PSI	100 PSI	250 PSI	500 PSI	600 PSI	700 PSI	800 PSI	1000 PSI	1200 PSI	1500 PSI	2000 PSI	2500 PSI	3000 PSI	3500 PSI	4000 PSI	5000 PSI
2	0.20	0.32	0.50	0.71	0.77	0.84	0.89	1.00	1.10	1.22	1.41	1.58	1.73	1.87	2.00	2.24
2.5	0.25	0.40	0.63	0.88	0.97	1.05	1.12	1.25	1.37	1.53	1.77	1.98	2.17	2.34	2.50	2.90
3	0.30	0.47	0.75	1.06	1.16	1.25	1.34	1.50	1.64	1.84	2.12	2.37	2.60	2.81	3.00	3.35
3.5	0.35	0.55	0.88	1.24	1.26	1.46	1.57	1.75	1.92	2.14	2.47	2.77	3.03	3.27	3.50	3.91
4	0.40	0.63	1.00	1.41	1.45	1.67	1.79	2.00	2.19	2.45	2.83	3.16	3.46	3.74	4.00	4.47
4.5	0.45	0.71	1.13	1.59	1.74	1.88	2.01	2.25	4.26	2.76	3.18	3.56	3.90	4.21	4.50	5.03
5	0.50	0.79	1.25	1.77	1.94	2.09	2.24	2.50	2.74	3.06	2.54	3.95	4.33	4.68	5.00	5.59
5.5	0.55	0.87	1.38	1.94	2.13	2.30	2.46	2.75	3.01	3.37	3.89	4.25	4.76	5.14	5.50	6.15
6	0.60	0.95	1.50	2.12	2.32	2.51	2.68	3.00	3.29	3.67	4.24	4.74	5.20	5.61	6.00	6.71
6.5	0.65	1.03	1.63	2.30	2.52	2.72	2.91	3.25	3.56	3.98	4.60	5.14	5.63	6.08	6.50	7.27
7	0.70	1.11	1.75	2.47	2.71	2.93	3.13	3.50	3.83	4.29	4.95	5.53	6.06	6.55	7.00	7.83
7.5	0.75	1.19	1.88	2.65	2.90	3.14	3.35	3.75	4.11	4.59	5.30	5.93	6.60	7.02	7.50	8.39
8	0.80	1.26	2.00	2.83	3.10	3.35	3.58	4.00	4.38	4.90	5.66	6.32	6.93	7.48	8.00	8.94
8.5	0.85	1.34	2.13	3.01	3.29	3.56	3.80	4.25	4.66	5.21	6.01	6.72	7.32	7.95	8.50	9.50
9	0.90	1.42	2.25	3.18	3.49	3.76	4.02	4.50	4.93	5.51	6.36	7.12	7.79	8.42	9.00	10.06
9.5	0.95	1.50	2.38	3.36	3.68	3.97	4.25	4.75	5.20	5.82	6.72	7.51	8.26	8.89	9.50	10.62
10	1.00	1.58	2.50	3.54	3.87	4.18	4.47	5.00	5.48	6.12	7.07	7.91	8.66	9.35	10.00	11.18

**GP PART NUMBER SYSTEM FOR M-TYPE NOZZLES** *(not included with nozzle holder)*

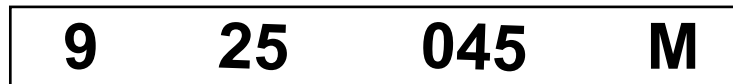

	PREFIX	DEGREE CODE	NOZZLE NUMBER	THREAD SIZE CODE
DESCRIPTION	"9" = Spray Tip Nozzle	"25" = Degree of Spray Angle	"045" = #4.5 Nozzle Size	"M" = 1/4" NPT-M Thread
Available Types	N/A	0°, 15°, 25°, 40°	#2.0, #2.5, #3.0, #3.5, #4.0, #4.5, #5.0, #5.5, #6.0, #6.5, #7.0, #7.5, #8.0, #8.5, #9.0, #9.5, #10.0	N/A

Note: Some special nozzle #s available upon request

**EXAMPLES**

- 900100M** > Stray Tip Nozzle, 0° Spray Angle, #10.0 Nozzle with a 1/4" NPT-M Thread
- 900035M** > Stray Tip Nozzle, 0° Spray Angle, #3.5 Nozzle with a 1/4" NPT-M Thread
- 925035M** > Stray Tip Nozzle, 25° Spray Angle, #3.5 Nozzle with a 1/4" NPT-M Thread
- 940090M** > Stray Tip Nozzle, 40° Spray Angle, #9.0 Nozzle with a 1/4" NPT-M Thread

