



* Hose Reel
Not Included

SPECIFICATIONS

- For all General Pump's A-frame hose reels
- Converts your General Pump hose reel into a hose reel cart
- Makes storage and moving of your fully loaded hose reel easy
- Stainless Steel hardware
- Powder coated steel frame
- Unique design - one kit can be used on all three hose reels
- Solid Polyurethane wheels will never go flat

PARTS LIST / DIMENSIONS

EXPLODED VIEW AND PARTS

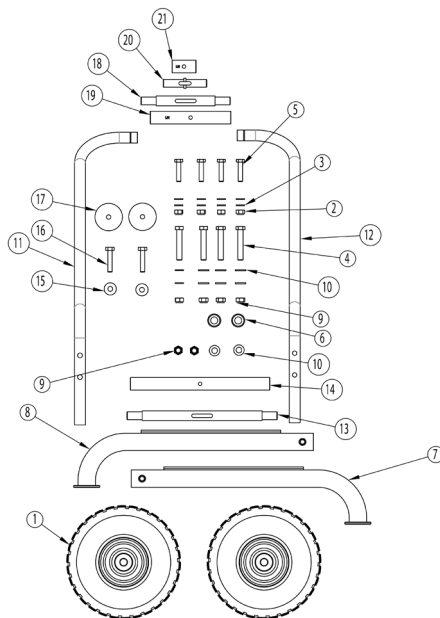

Pos.	Part #	Description	QTY
1	DP80052	WHEEL, 10"	2
2	2203017	NUT, M10, NYLOK, SST	4
3	2203413	WASHER, FLAT, M10	8
4	2200114	BOLT, M12	4
5	2200113	BOLT, M10 X 45	4
6	2660330	BUSHING, CART	2
7	2103306	ASSY, SUB, FRAME, RIGHT	1
8	2103305	ASSY, SUB, FRAME, LEFT	1
9	2203019	NUT, M12, NYLOK, SST	6
10	2203418	WASHER, FLAT, M12	10
11	2550210	HANDLE, CART	1
12	2550211	HANDLE, CART	1
13	2530126	HANDLE, SPACER	1
14	2550212	HANDLE, CENTER	1
15	2200035	WASHER, M10	2
16	2200101	BOLT, M10 X 50	2
17	2700016	FOOT, CART	2
18	2530127	HANDLE, SPACER	1
19	2550213	HANDLE, CENTER	1
20	2530128	HANDLE, SPACER	1
21	2550214	HANDLE, CENTER	1

DIMENSIONS MM, [IN]	DHRA50150	DHRA50300	DHRA50450
A	994 [39.13]	994 [39.13]	994 [39.13]
B	657 [25.87]	657 [25.87]	657 [25.87]
C	531 [20.91]	661 [26.02]	801 [31.54]

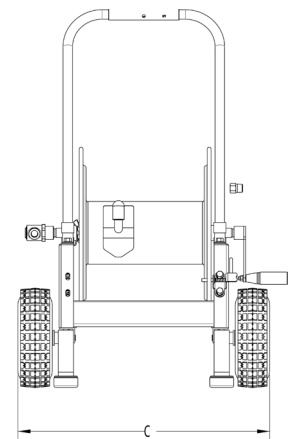
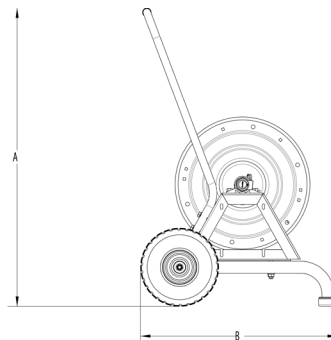

General Pump
is a member of
the Interpump Group



Ref 301030 Rev. B
09-21

ASSEMBLY / OPERATING INSTRUCTIONS

Figure 1: Use (4) M12 nuts, bolts and washers to assemble the hose reel to the two rails. Be sure the hose base slides into the gaps on the two rails. The lock pin needs to go toward the front or bent part of the rail. Tighten the nuts.

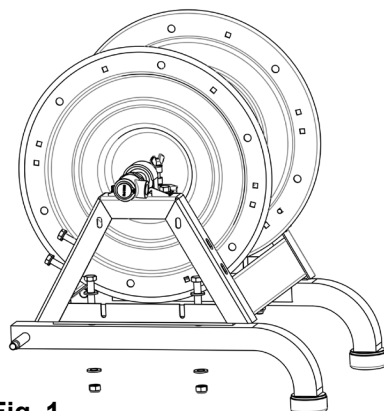
**Fig. 1**

NOTE: All hardware is stainless steel. A little oil or anti-seize on the threads will help prevent galling.

Figure 3: Look at the top of the handles. The top is the end opposite the end with the (2) holes. One handle is marked, LH, for left hand threads. Take the handle that is NOT marked and bolt it to the wheel side of the hose reel with the top bent portion facing toward the center of the reel. Use the (2) M10 nuts, bolts and washers. Do NOT tighten yet.

Find the correct handle connector for your hose reel. There are three:
Short DHRA50150
Medium DHRA50300
Long DHRA50450

One end of the handle connector is marked LH; this end has left hand thread. Take the end that is NOT marked and thread it onto the top of the handle (that is already bolted to the hose reel) $\frac{1}{2}$ OR 1 TURN ONLY - just enough to hold it onto the handle. Remember, these are left hand threads. Find the correct handle connector stiffener and slide it into the connector as far as it will go.

**Fig. 2**

Figure 2: Slide the (2) plastic bushings onto the axles. The bevel on the bushing goes toward the rail. Then slide the wheels on, followed by the M12 washers and nuts. Tighten the nuts.

**Fig. 3**

ASSEMBLY / OPERATING INSTRUCTIONS

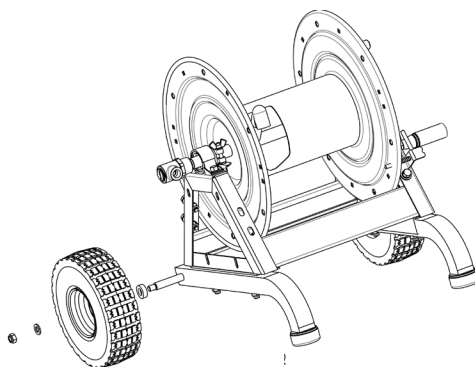
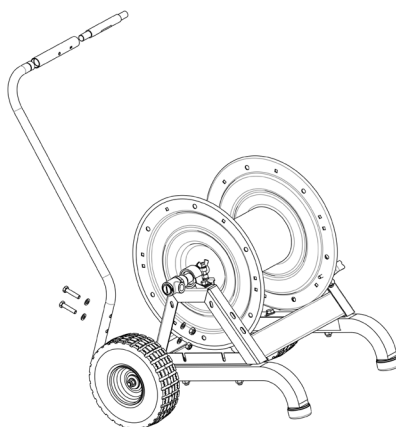
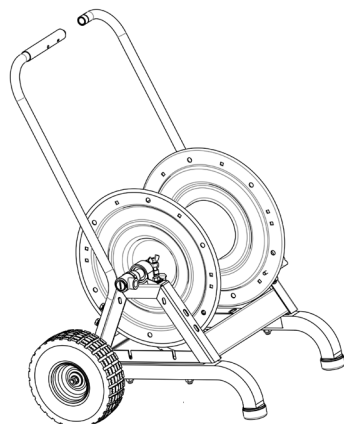

Fig. 4

Figure 4: Take the other handle, marked LH, and slip it over the stiffener while threading it onto the connector. This is a little tricky as the handles move around, but once it's started it goes on pretty easily. You can do this part by hand. Remember these threads are left hand threads.

Once the connector has several threads engaged, you can line up the hole in the connector with the slot in the stiffener. Put a screwdriver all the way through both parts and tighten the connector completely.

Use the remaining M10 nuts, bolts and washers to attach the second handle to the reel. Tighten these and the other handle bolts.

SAFETY / WARNING

SAFETY PRECAUTIONS

1. Make sure incoming pressure does not exceed the rated pressure.
2. Use proper eye protection when assembling and using hose reels.
3. Assemble the hose reel kit on a clean workbench free of debris and moisture.
4. Use soap and water when checking for air leaks.
5. Keep children away from work area.

WARNING!

Exposure of skin directly to pressurized air or fluids could result in severe bodily injury!