

FEATURES

- Reduced pressure loss
- Makes for easier gun operation
- Extremely reliable
- Easy maintenance
- Includes knob fitted with locknut for easy pressure adjustment
- Integrated micro switch that activates upon gun closer, can be wired as normally open or normally closed



SPECIFICATIONS

PART NUMBER	2100242MS	
Maximum Volume	8.0 GPM	
Rated Pressure	4000 PSI	
Maximum Pressure	4000 PSI	
Maximum Temperature	185°	
<p>Note: The valve has been designed for continuous use at a water temperature of 140° F. It can operate for short periods at a maximum temperature of 185° F.</p>		
Port Sizes	Inlet	3/8" NPT-F
	Outlet	3/8" NPT-F
	Bypass	(2) 3/8" NPT-F
Overall Dimension	7.3" x 3.1" x 2.0"	
Weight	1.5 Lbs.	
Amperage	2 amps ind.	
	6 amps res.	
Lead Length	36"	

MUST use a safety relief device in conjunction with this unloader valve when installed on a positive displacement pump. General Pump is not liable and assumes no responsibility when used in a customer's high pressure system.

DIMENSIONS

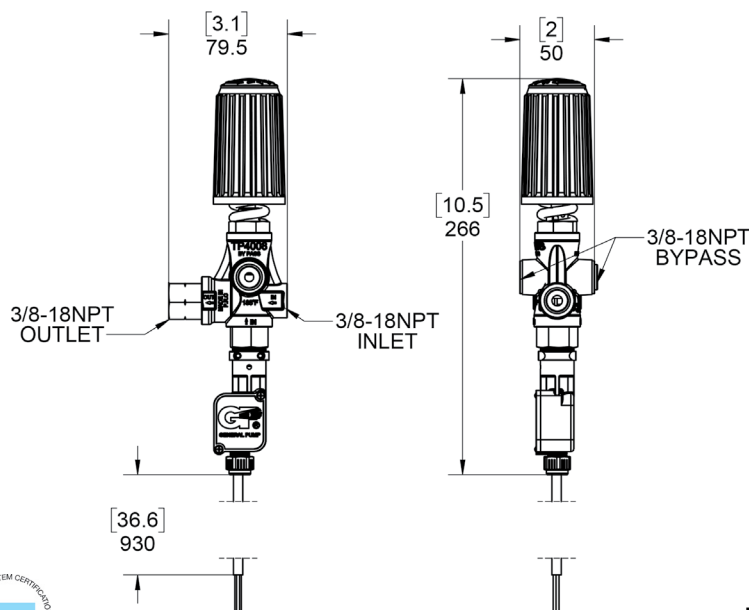

Trapped Pressure Unloader Valve with Micro Switch

PARTS LIST

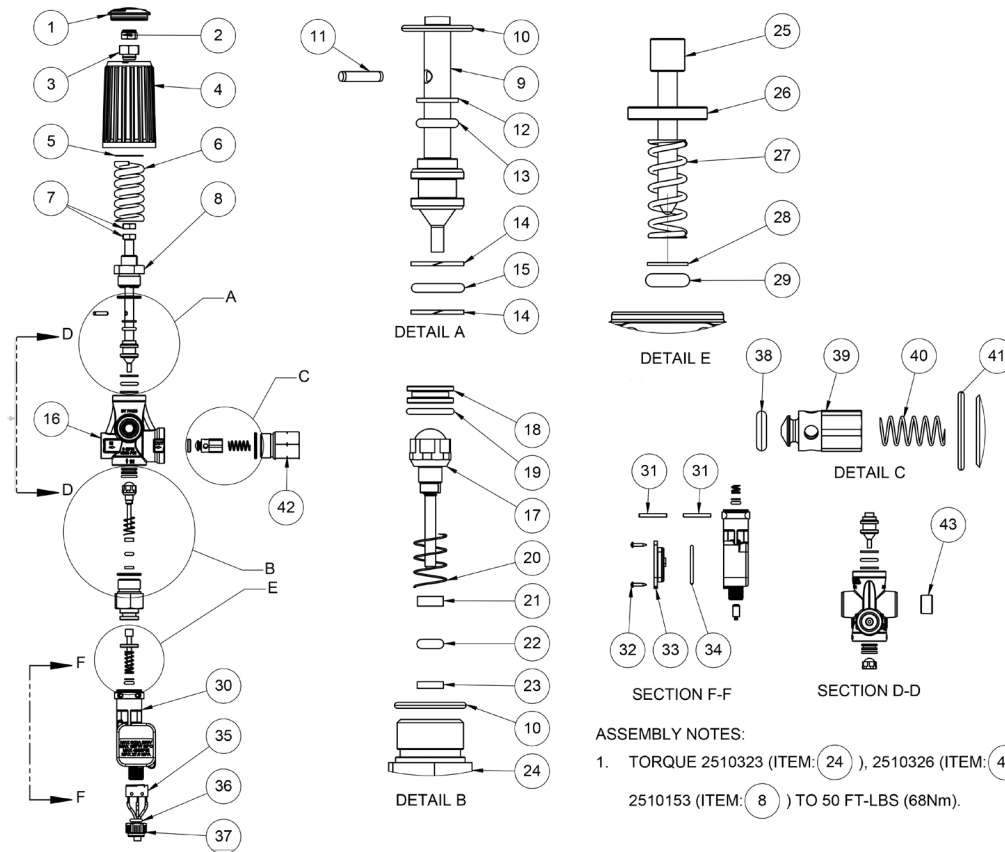

ASSEMBLY NOTES:
 1. TORQUE 2510323 (ITEM: 24), 2510326 (ITEM: 42) AND 2510153 (ITEM: 8) TO 50 FT-LBS (68Nm).

NO.	PART NO.	DESCRIPTION	QTY.
1	2660143	CAP, KNOB	1
2	2200053	NUT, M8X1.25	1
3	2510152	INSERT, BRASS	1
4	2660142	HANDLE	1
5	2203408	WASHER	1
6	2720024	SPRING	1
7	2203008	NUT, M8	2
8	2510153	FITTING, STEM	1
9	2520083	STEM	1
10	2701040	O-RING	2
11	2202016	PIN, LOCK	1
12	2710011	RING, BACKUP	1
13	2701044	O-RING	1
14	2710012	RING, BACKUP	2
15	2701043	O-RING	1
16	2452010	FORGING	1
17	2103172	SHUTTLE ASSY, PIN / BALL, FOR MICRO SWITCH UNLOADER	1
18	2520081	SEAT	1
19	2701055	O-RING	1
20	2720021	SPRING, BYPASS	1
21	2510004	WASHER, BRASS	1
22	2701048	O-RING	1

NO.	PART NO.	DESCRIPTION	QTY.
23	2710018	WASHER, TEFLON	1
24	2510323	FITTING, MICRO SWITCH	1
25	2510324	BRASS PIN, MICRO SWITCH	1
26	2202050	BIG WASHER, BRASS	1
27	2720045	SPRING, MICRO SWITCH	1
28	2202049	BRASS WASHER, MICRO SWITCH	1
29	2701106	O-RING, 3.63X2.62, NBR70	1
30	2660448	HOUSING, MICRO SWITCH	1
31	2520249	PIN, 3X25, SS	2
32	2200168	SCREW, ST2.6X12, SS	2
33	2660449	COVER, MICRO SWITCH	1
34	2701105	O-RING, 31X2.50, NBR70	1
35	2103171	WIRE, 3X0.75, MICRO SWITCH	1
36	2701107	O-RING, 6.02X2.62, NBR70	1
37	2660450	NUT, G1/4	1
38	2701042	O-RING	1
39	2520111	POPPET	1
40	2720020	SPRING, POPPET	1
41	2701041	O-RING	1
42	2510326	FITTING, OUTLET, M22X3/8NPT-F, BRASS	1
43	2510149	PLUG, 3/8 NPT	1

Trapped Pressure Unloader Valve with Micro Switch**WIRING DIAGRAM****Contact Form**

● SPDT

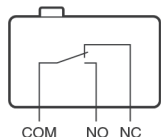

● SPST-NC

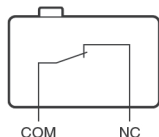

● SPST-NO

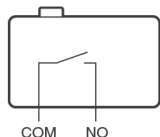
**Red - COM****Blue - NC****Brown - NO****SELECTION AND OPERATION****SELECTION**

This product is intended to be incorporated on a finished machine. This product is to be used with clean fresh water, for use involving different or corrosive liquids, contact the GP Customer Service Department. Appropriate filtration should be installed when using impure liquids. Choose the valve appropriate to the working data of the pump (permissible pressure, flow and rated temperature of the system). The pressure of the pump must not exceed the maximum pressure of the valve.

OPERATION

The valve regulates the maximum pressure of the system by varying the flow discharged by the bypass. The adjustment is made by altering, by means of a piston, the position of a sphere which partially closes the bypass opening. The valve is sensitive to water flow. At gun opening, the water flows through the valve which maintains the system in pressure until the gun closes, the interruption of the flow provokes the complete aperture of the bypass which allows to discharge the flow at low pressure. At gun closure, the special mechanism of zero setting, which does not include a check valve, keeps in connection the delivery line and the bypass line, in that way permitting to lower the pressure all around the system and not only in the source line of the valve.

INSTALLATION

This valve, on a system that produces hot water, must be fitted upstream from the source of heat. On a system that generates hot water, it is advisable to use accessories that limit the accidental increase of fluid temperature. **Always install a safety valve.** We recommend the use of a nozzle with flow rate which allows a regular discharge from the valve bypass of at least 5% of the flow supplied by the pump. In order to achieve a constant pressure and easy adjustment. If the nozzle wears out, the pressure decreases. To reset pressure back to working level, it is necessary to replace the worn nozzle. When a new nozzle is fitted, resetting of the system to its original working pressure is required.

DISCHARGE SYSTEM AND WATER ADDUCTION

The bypass discharge can be sent back to the pump intake or returned into a tank; in such cases it is advisable that the tank be fitted with baffles to reduce eventual turbulence and air bubbles which could be harmful to the pump.

PRESSURE ADJUSTMENT/CALIBRATION

The desired working pressure must be adjusted with the system running and the gun opened. Adjust the pressure by screwing or unscrewing the adjustment knob. The operation is easier if the correct nozzle has been chosen (see above). When screwing the adjustment knob a consequent pressure increase must be matched. If, before reaching the desired pressure, there is no pressure increase, **DO NOT FORCE.** Rather, check the correct ratio of nozzle/flow rate - pressure and, if necessary, replace with a smaller size nozzle.

ATTENTION: the nut in position 7 is a mechanical security device that limits the maximum pressure; it must absolutely NOT be removed.

MAINTENANCE

STANDARD: every 400 working hours, check and lubricate the seals with water resistant grease.

SPECIAL: every 800 working hours, check the wear of the seals and internal parts and, if necessary, replace with original GP parts taking care, during installation, to lubricate with water resistant grease.

The manufacturer is not to be considered responsible for damage as a result from incorrect fitting and maintenance.

Trapped Pressure Unloader Valve with Micro Switch**TROUBLESHOOTING**

PROBLEMS	PROBABLE CAUSES	SOLUTIONS
Frequent valve recycles	Damaged check valve O-ring Leaking connections Restricted bypass or too small diameter of the bypass hose	Replace Check or renew Clean or adapt passage diameter
Valve does not reach pressure	Piston O-rings worn out Debris between seat and shutter Seat worn out Nozzle worn out Incorrect choice of nozzle	Replace Clean the seat Replace Replace Fit with smaller nozzle
High pressure peaks at gun closure	There is not a minimum of 5% of total flow discharged in bypass Excessive flow in bypass Adjustment with spring totally compressed	Reset Correctly Change type of valve or adjust passages Loosen adjustment screw and eventually fit with smaller nozzle
Valve does not discharge at low pressure at gun closure	Jammed check valve Debris on check valve	Clean or replace Clean

WARNINGS

WARNING: High Pressure Systems require a primary pressure regulating device (i.e. regulator, unloader) and a secondary pressure relief device (i.e. pop-off valve, relief valve). Failure to install such relief devices properly could result in personal injury or damage to pump or property. GP does not assume any liability or responsibility for the operation of the user's high pressure system.



During use, never exceed the maximum values of pressure, flow rate and temperature as stated in this document.

Maintenance and repair must be carried out by qualified and authorized staff only. Replace the filter parts with original spare parts only.

From time to time, it is necessary to check that the parts which are under pressure do not show cracks and/or leakages; the frequency of this check depends on the actual use. Inspect and clean the screen regularly.



WARNING: This product can expose you to chemicals including lead, which is known to the state of California to cause cancer and birth defects or other reproductive harm. For more information, go to www.P65Warnings.ca.gov