

Clutches For 24mm Solid Shaft Pump

Typical Mobile Clutch - Water Pump Applications In typical water pump applications, the clutch is mounted on the input shaft of the water pump. Since the clutch has an integral pulley, a belt is used as the input to the clutch. This belt is normally driven directly from an electric motor or a gas/diesel engine. When there is no power to the clutch, the water pump does not engage; however when power is activated, the clutch drives the water pump to initiate water flow. In this application, the GP clutch is mounted directly to a General Pump by using an adapter plate.

Used in Carpet Cleaning, Texture Spray Machines, High Pressure Pump applications.

SPECIFICATIONS

Pulley Size & Type:	12.4" Pitch - B Groove, 24mm Shaft	
Static Torque	Initial Torque:	80 Nm (59 Ft.lbs.)
	Final Torque:	237 Nm (175 Ft. lbs.)
Power Requirement:	12V	50 Watts
Weight:	100976	31.0 lbs.
	100977	24.0 lbs.

Part Number	Description
100976	Clutch w/Mounting Plate 47 and 66 Series, 12V, Dual Groove, 12.4" Pulley
100977	Clutch w/Mounting Plate 47 and 66 Series, 12V, Single Groove, 12.4" Pulley
NOTE: This clutch kit to be used with tapped crankshafts only.	

Reasons for using an Electromagnetic Clutch

- Extended pump life
- Less Cost
- Simple installation
- Operator convenience
- Cold weather starting

General Pump Mobile Clutch Design Advantages

- **Solid forged rotor.** A one-piece solid forged rotor means no chance of internal parts separation. They have an even wall thickness around the coil which gives optimum flux distribution, maximizing torque.
- **High temperature, longer-life grease.** Our special long-life grease has shown a significant improvement in life over other standard high temp greases.
- **E-coating.** Where possible, all parts in the clutch are e-coated to give maximum corrosion protection.
- **High-temperature epoxy coil.** To help prevent failure from vibration and outside contaminants, all coils are sealed in the coil shell with a high-temperature epoxy coating.
- **Forged machined pulley.** All GP models use a heavy-duty machined pulley. A stronger pulley resists damage due to abusive environments.
- **Clutches are also available mounted on a General Pump. Please contact your sales representative.**



General Pump
is a member of
the Interpump Group



Ref 300730 Rev. D
11-18



100976 / 100977

For 24mm Solid Shaft Pump



100976 PARTS LIST

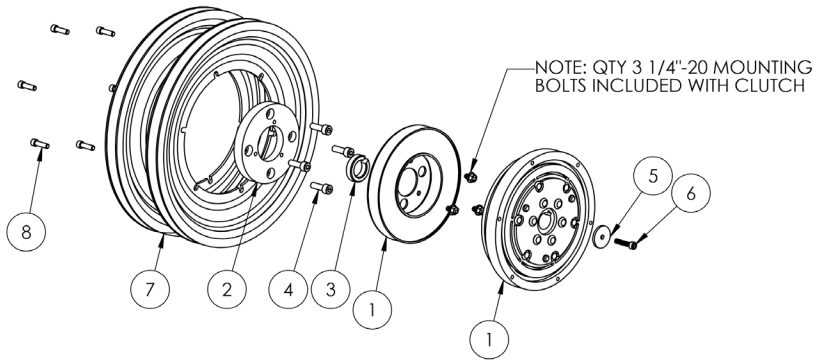

Item	Part #	Description	QTY
1*	103097	Clutch	1
2	500014	Mounting Plate	1
3	500015	Shaft Spacer	1
4	200059	SHCS, M8, 1.25x25mm	4
5	203002	Washer, .25x1.25x.125	1
6	200026	SCHS, M6, 1.0x35mm	1
7	540055	Pulley	2
8	201021	SHCS, 1/4-20x1/8"	6
*	N/A	Includes: Bolt, HHCS 1/4"-20 x 3/8"	3

100977 PARTS LIST

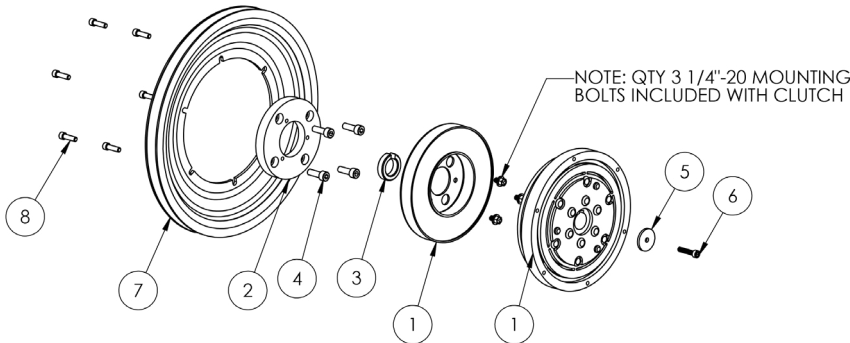

Item	Part #	Description	QTY
1	103097	Clutch	1
2	500014	Mounting Plate	1
3	500015	Shaft Spacer	1
4	200059	SHCS, M8, 1.25x25mm	4
5	203002	Washer, .25x1.25x.125	1
6	200026	SCHS, M6, 1.0x35mm	1
7	540055	Pulley	1
8	201021	SHCS, 1/4-20x1/8"	6
*	N/A	Includes: Bolt, HHCS 1/4"-20 x 3/8"	3

100976 / 100977

For 24mm Solid Shaft Pump

GENERAL PUMP A member of the Interpump Group

MOUNTING INSTRUCTIONS



1. Remove four bolts from side cover. Mount adapter plate to pump. Apply Loctite 243 thread locker to bolts and torque to 14.7 Ft. Lbs.

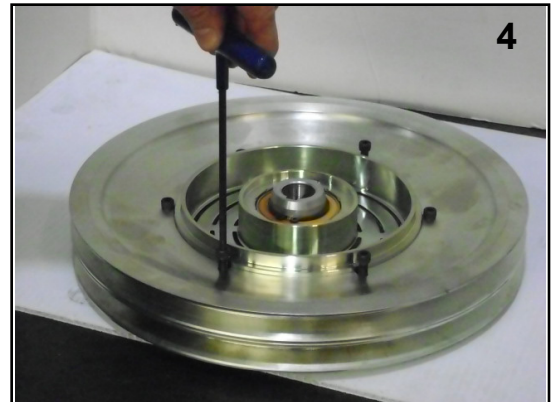

4. Mount pulley(s) to clutch assembly and apply Loctite 243 thread locker to bolts. Torque bolts to 8.8 Ft. Lbs.

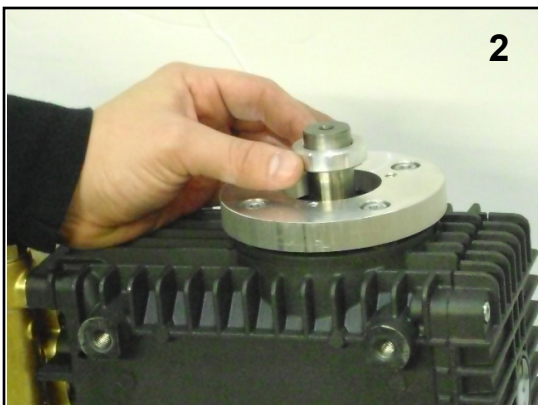

2. Install spacer ring on shaft.



5. Apply anti-seize lubricant to pump shaft. Slide pulley/clutch assembly onto pump. Fasten using bolt with washer. Apply Loctite 243 thread locker to bolt and torque to 8.8 Ft. Lbs.

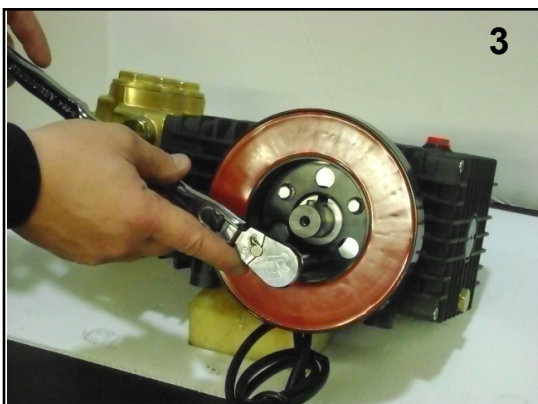

3. Mount coil to adapter plate. Torque bolts to 7.3 Ft. Lbs.