



Protects the pump from damaging heat build-up while it is in bypass mode. The thermal relief valve, sensing a rise in temperature, opens and discharges a small amount of heated fluid. This allows cooler water to enter the system and cool the pump. When the gun is discharged the cooler water will cause the valve to close immediately.

FEATURES/BENEFITS

- Most consistent temperature range on the market
- Quickest response to rising temperature
- Less stress on pump
- Most cost effective thermal protector in the market
- Mounts easily in the pump inlet, supply lines or bypass loop

SPECIFICATIONS

Part Number	Temp	Description
100677 no hose barb	190° F*	3/8" NPT
100678 no hose barb	190° F*	1/2" NPT
100679 SS hose barb	190° F*	3/8" NPT
100680 SS hose barb	190° F*	1/2" NPT
100156 SS hose barb	145° F*	3/8" NPT
Pressure Range		10 - 90 PSI
Hose Barb:		90°, 1/4"
Weight:		1.5 oz
Dimensions		1-1/2" H x 1" W
Materials		Brass, Buna, Delrin, Stainless Steel

* Activation temperature varies with system pressure.

DIMENSIONS

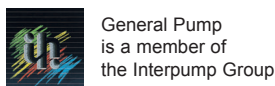
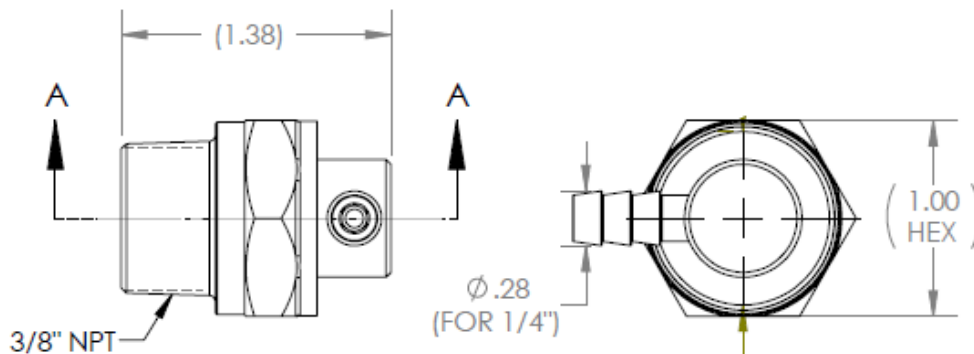

Ref 310064 Rev C
01-20

