

Fixed Chemical Injector

Stainless Steel Body and Nozzle

FEATURES

- Designed specifically for car wash applications
- Made in the USA
- A cost effective solution to your chemical application needs
- Full Kynar hose barb for increased chemical resistance



SPECIFICATIONS

MODEL	100096	100097	100174	100175
Orifice	1.45 mm	2.2 mm	2.8 mm	2.8 mm
Flow Rate	1.0 to 2.0 GPM	3.0 to 5.0 GPM	6.0 to 9.0 GPM	6.0 to 9.0 GPM
Pressure	250 PSI			
O-Ring Material	EPDM			Viton
Inlet	3/8" NPT-M			
Outlet	3/8" NPT-M			
Max. Temperature	190° F			
Hose Barb	1/4"			
Weight	.4 lbs.			
Materials	304 SS, Kynar, Teflon, EPDM or Viton			

DIMENSIONS

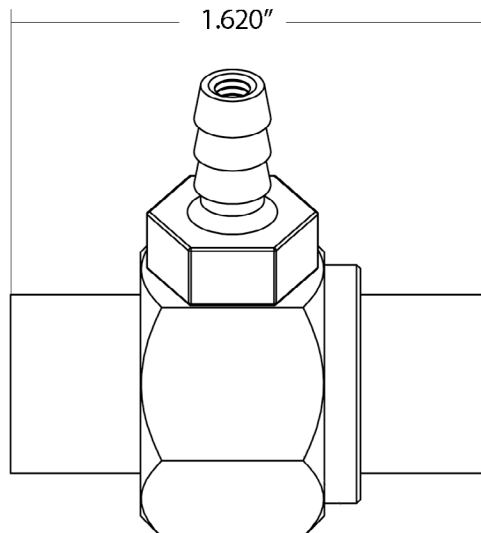

General Pump
is a member of
the Interpump Group



Ref 300691 Rev. B
09-22



Fixed Chemical Injectors

SS Body and Nozzle

PARTS LIST

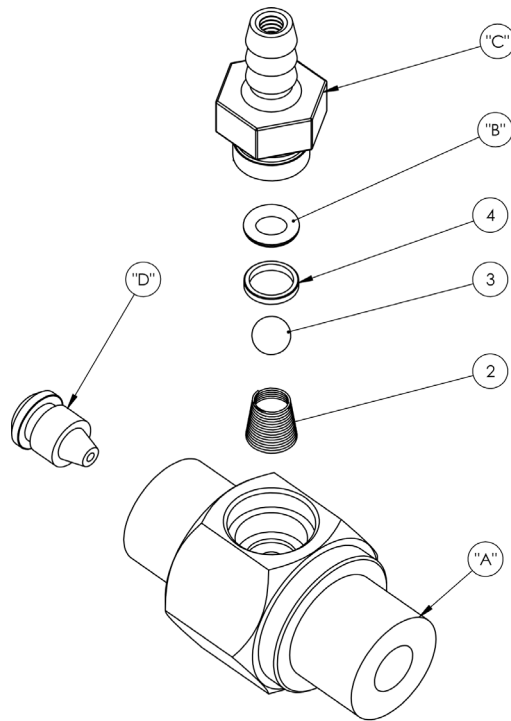

Pos.	Part No.	Description	QTY.
1	520120	Body, Injector, SS, Ø 0.076 (100096)	1
	520119	Body, Injector, SS, Ø 0.116 (100097)	1
	520121	Body, Injector, SS, Ø 0.150 (100174)	1
	520121	Body, Injector, SS, Ø 0.150 (100175)	1
2	720038	Spring, Conical, .437 FL	1
3	660114	Ball, 7/32	1
4	660110	Retaining Ring, Kynar	1
5	701008E	O-ring, EPDM, (100096, 100097, 100174)	1
	701032	O-ring, Viton, (100175)	1
6	660259RD	Hose Barb, Injector, Red, (100096)	1
	660259BL	Hose Barb, Injector, Blue, (100097)	1
	660259WT	Hose Barb, Injector, White, (100174, 100175)	1
7	520072	Nozzle, Injector, Ø .057, 316 SS, (100096)	1
	520065	Nozzle, Injector, Ø .086, 316 SS, (100097)	1
	520327	Nozzle, Injector, Ø .110, 316 SS, (100174, 100175)	1

Fixed Chemical Injectors

SS Body and Nozzle

GENERAL PUMP A member of the Interpump Group

INSTALLATION

This product is to be used with clean, fresh water. For different or corrosive liquids, contact GP Technical Service Department. With not clean liquids, appropriate filtration should be installed. Select the injector based on the nominal operating rating: system rated pressure, max flow and max temperature. Install valve with direction arrow pointing downstream. For proper operation a control device such as a dual lance wand, quick couple nozzles, or an adjustable nozzle holder must be used to lower the system pressure at the nozzle.

Under no circumstances should the pressure of the system exceed the maximum rated pressure of any component.

TROUBLESHOOTING

PROBLEM	CAUSE	SOLUTION
Injector will not draw liquid	Incorrect nozzle System is not in low pressure mode Discharge hose is too long Chemical line is clogged	Check and change nozzle Change or adjust nozzle to put system in low pressure mode Reduce length of discharge hose or change injector* Clear chemical line of obstruction
Rate of draw seems too slow	Discharge hose is too long Air leak in chemical line Chemical is too viscous	Reduce length of discharge hose or change injector* Locate and repair leak Reduce chemical with water to decrease its viscosity
Chemical injector is leaking from hose barb	Obstruction in hose barb check valve Damaged o-ring in check valve	Disassemble and remove obstruction Remove and replace o-ring
Excessive pressure load on pump, motor or engine	Clogged injector Improperly sized injector orifice	Clear injector orifice of obstruction Change orifice*
*Contact GP Technical Service for Assistance		

