

FEATURES

- Triplex plunger pump
- Forged brass manifold
- New plunger guide bushing (patent pending)
- Solid ceramic plungers with dual guide system
- New optimized outlet valves
- Exclusive protection chamber between crankcase and manifold
- New dual lip oil seal



SPECIFICATIONS

Pump Model	ES2212S	ES2213S	ES1810S	ES2010S	ES2012S	ES2013S
Maximum Volume	4.76 GPM	5.55 GPM	3.43 GPM	3.96 GPM	4.76 GPM	5.55 GPM
Maximum Discharge Pressure	3,000 PSI		4,000 PSI			3,600 PSI
Horsepower	9.8 EBHP	11.45 EBHP	9.4 EBHP	10.9 EBHP	13.0 EBHP	13.6 EBHP
Maximum Pump Speed	1450 RPM		1750 RPM			
Maximum Inlet Pressure	125 PSI					
Plunger Bore (in / mm)	.866 in./22 mm		.709 in./18 mm	.787 in./20 mm		
Plunger Stroke (in / mm)	.472 in./12 mm	.512 in./13 mm	.394 in./10 mm		.472 in./12 mm	.512 in./13 mm
Oil Capacity	22 oz. (.65 liter)					
Maximum Fluid Temperature	165° F					
Inlet Port Thread	1/2"-14 BSP-F					
Discharge Port Thread	3/8"-19 BSP-F					
Shaft Diameter	.945 in./24 mm					
Weight	21 lbs.					
Dimensions - Nominal	10.4" x 8.8" x 5.4"					

TRIPLEX

TRIPLEX



General Pump
is a member of
the Interpump Group

Ref 300951 Rev.C
01-16



Instructions and Recommendations for the Installation of *ES Series Pumps*

Maximum temperature of the water through the pump is 165°F (73°C).

In order to obtain maximum performance in terms of duration of seals and valves, it is necessary to respect a few simple rules, as follows:

1) **In order to avoid damage caused by cavitation, the pump must be pressure fed.**

The higher the inlet pressure, the longer the life of the wet end of the pump.

When working at 165°F (73°C), the minimum feed pressure - measured directly in the inlet port of the pump when it is working - is 45 psi (3 bar).

The minimum feed pressure according to the different temperatures are:

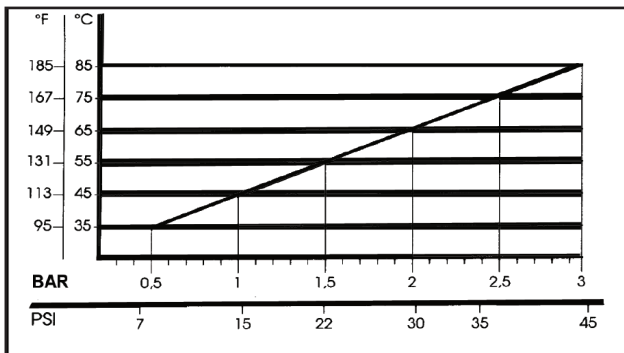

Naturally, if the application allows for feeding the pump with 45 psi (3 bar) even at low temperatures (for example: 115°F/45°C the life of the wet end of the pump will be even longer.

2) **The plumbing which feeds the pump must be of a diameter at least equal to the inlet port.**

Also, follow the suggestions below:

a) Make the plumbing as short and straight as possible, preferably in an upward direction to facilitate the expulsion of eventual air bubbles naturally if compatible with the requirements of the system.

b) It is always useful to put a filter at the inlet with capacity of 4 to 5 times the flow of

the pump, for example for a 4 gpm (15 l/min) pump, put a filter from 16 to 20 gpm (60-75 l/min). The mesh size suitable for this application is 0.016" (.4 mm).

c) It is extremely important to put a pressure switch on the suction port of the pump, and in any case downstream from the filter, so that it can stop the pump should the feed pressure drop by 20% due to the filter clogging or failure of the feed pump, etc.

3) **Change of oil**

We recommend the **first oil change after the first 50 hours**, with the **pump stopped** and the **oil still warm**.

This change is not recommended because the oil has lost its properties, but rather to eliminate the impurities that have gotten into the oil during the break-in phase. If these impurities are not removed, but are allowed to remain in the oil, they *may cause premature wear* to the moving parts and the oil seals. **After this initial change, the oil can then be changed every three months or 300 hours of operation thereafter.**

Please note: If the pump works in conditions with high humidity and with sharp temperature changes, it is possible that condensation will appear inside the crankcase, which mixing with the oil can change its properties. This is easy to see because the oil changes to a white, milky color.

If the pump does not have excessive water leaking from the packings, and the oil becomes milky, the oil has to be changed more frequently. The percentage of water in the oil must not exceed 20%.

Use oil per the following chart:

CHART OF COMPATIBLE OILS SAE15W40	
General Pump	Series 100
BP	VISCO 2000
CASTROL	CWX
MOBIL	SUPER
SHELL	HELIX SUPER
TOTAL	QUARTZ 4000-5000

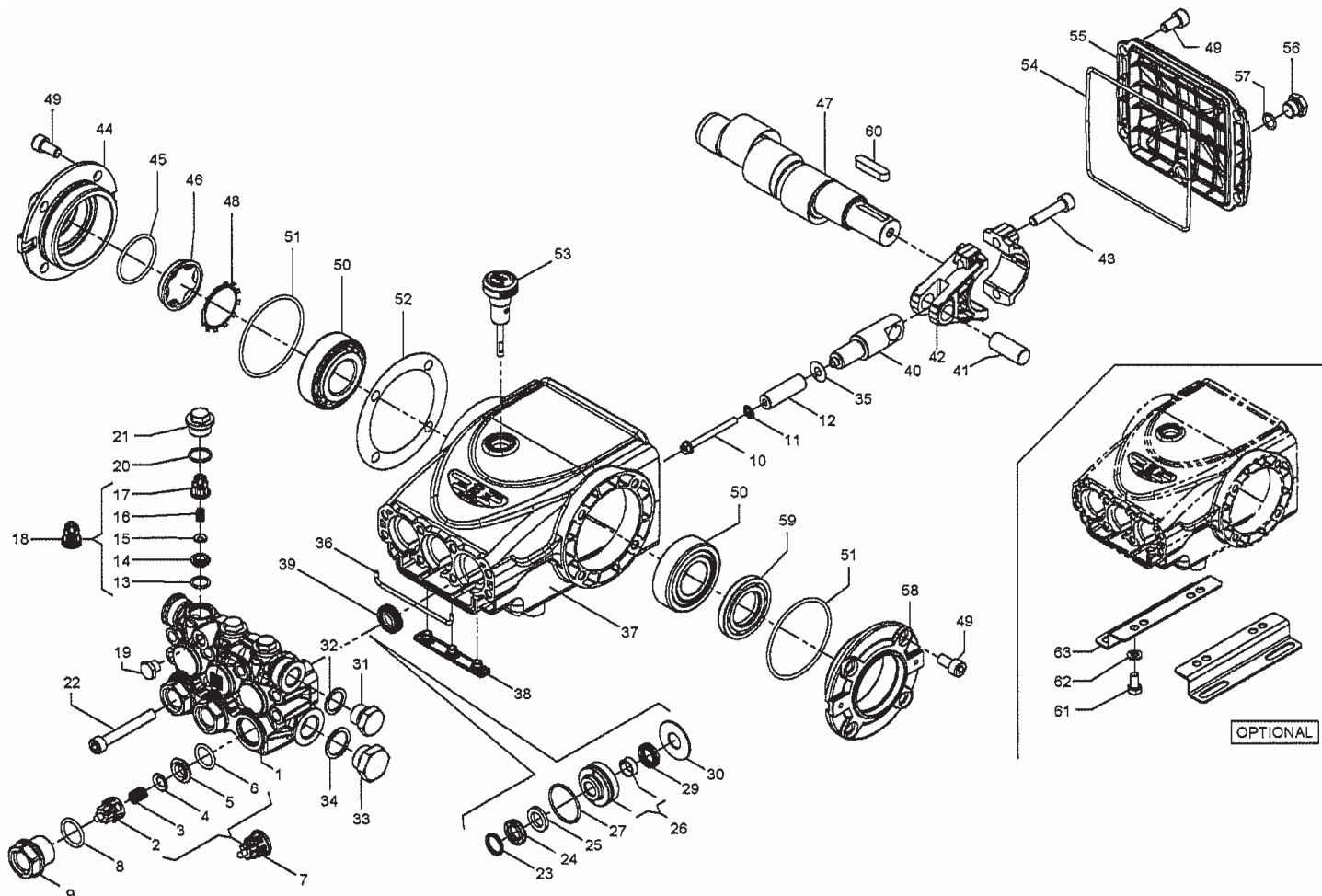

PARTS LIST

ITEM	PART NO.	DESCRIPTION	QTY	ITEM	PART NO.	DESCRIPTION	QTY	ITEM	PART NO.	DESCRIPTION	QTY
1.	59120241	Manifold, Ø 18	1	24.	90269100	Packing, Ø 20, HP	3	43.	99309900	Connecting Rod Screw	6
	59120341	Manifold, Ø 20	1		90271600	Packing, Ø 22, HP	3	44.	47151222	Crankcase Cover, Side	1
	59120441	Manifold, Ø 22	1		90265350	Packing, Ø 18, HP	3	45.	90387700	O-ring, Ø 39.34x2.62	1
2.	36202551	Valve Cage	3	25.	90511150	Anti-ext. Ring, Ø 18	3	46.	70211801	Sight Glass	1
3.	94767600	Spring, Ø 9.4x14.8	3		90513400	Anti-ext. Ring, Ø 20	3	47.	59020135	Crankshaft	1
4.	36200176	Valve, Spherical	3		90514850	Anti-ext. Ring, Ø 22	3			(ES2013S, ES2213S)	
5.	36200366	Valve Seat, Inlet	3	26.	59606001	Intermed. Ring, Ø 18	3	59020234	Crankshaft	1	
6.	701115	O-ring, Ø17.13x2.62	3		59606101	Intermed. Ring, Ø 20	3			(ES2012S, ES2212S)	
7.	36711501	Valve Assembly	3		59606201	Intermed. Ring, Ø 22	3	59020335	Crankshaft,	1	
8.	701002	O-ring, Ø20.24x2.62	3	27.	90361200	O-ring, 31.47x1.78	3			(ES1810S, ES2010S)	
9.	98222600	Valve Cap, M24x1.5x16.7	3	29.	90269000	Seal, Ø 20, LP	3	48.	90075600	Retaining Clip	2
10.	99169000	Plunger Bolt, M5x55	3		90271500	Seal, Ø 22, LP	3	49.	99303900	Screw, M8x16	12
11.	96690500	Washer, Ø 5x11.5x0.4	3		90265000	Seal, Ø 18 LP	3	50.	640047	Tapered Roller Bearing	2
12.	58040209	Plunger, Ø 18x42	3	30.	59210770	Support Ring, Ø 18,	3	51.	90391300	O-ring, Ø 67.95x2.62	2
	59040009	Plunger, Ø 20x42	3		59210870	Support Ring, Ø 20	3	52.	97568000	Shim, 0.3 mm	1
	59040109	Plunger, Ø 22x42	3		59210970	Support Ring, Ø 22	3		97597800	Shim, 0.1 mm	1
13.	701014	O-ring, Ø 12.42x1.78	3	31.	98210000	Plug, 3/8"x13	1	53.	98210500	Oil Dipstick	1
14.	36211366	Outlet Valve Seat	3	32.	96738000	Gasket, 17.5x23x1.5	1	54.	90392200	O-ring, Ø133.02x2.62	1
15.	36211276	Outlet Valve Poppet	3	33.	98217600	Plug, 1/2" BSPx10	1	55.	59160022	Rear Cover	1
16.	94733300	Spring, Ø 6.2x10.4	3	34.	96751400	Gasket, Ø 21.5x27x1.5	1	56.	98204250	Plug, 1/4"x9	1
17.	36211151	Outlet Valve Cage Guide	3	35.	96699000	Washer, Ø 7.5x23x0.5	3	57.	701013	O-ring, Ø 10.82x1.78	1
18.	36719301	Complete Outlet Valve	3	36.	59211082	Gasket, Ø 3x103	1	58.	47151022	Side Cover	1
19.	98196600	Plug	3	37.	59010022	Crankcase	1	59.	90164800	Oil Seal, Ø 30x55x7	1
20.	701016	O-ring, Ø 15.6x1.78	3	38.	58210451	Drip Cover	1	60.	91489200	Key	1
21.	98213700	Outlet Valve Cap, M18x1.5x10	3	39.	90156550	Oil Seal, Ø 15x24x5.7	3	61.	99303700	Screw, M8x16	4
22.	99317500	Screw, M8x60	8	40.	59050066	Piston Guide	3	62.	96701600	Washer, Ø 8.4	4
23.	66100751	Head Ring, Ø 20	3	41.	97739900	Piston Pin, Ø 14x34	3	63.	50200074	Pump Foot	2
	66100951	Head Ring, Ø 22	3	42.	59030001	Connecting Rod	3				
	63101051	Head Ring, Ø 18	3								

REPAIR KITS

TORQUE SPECS*

KIT NO.	K269	K270	K271	Ø 18		Ø 20		Ø 22	
				K284	K289	K285	K290	K286	K291
ITEM NO'S INCLUDED IN KIT	2, 3, 4, 5, 6, 13, 14, 15, 16, 17, (7), (18)	8, 9, 20, 21	39	23, 24, 25, 27, 29	23, 24, 25, 26, 27, 29, 30	23, 24, 25, 27, 29	23, 24, 25, 26, 27, 29, 30	23, 24, 25, 27, 29	23, 24, 25, 26, 27, 29, 30
NUMBER OF ASSY'S IN KIT	6	6	3	3	1	3	1	3	1
NO. OF CYLINDERS KIT SERVICES	3	3	3	3	1	3	1	3	1

Position	Ft.-Lbs.	Nm.
9	96	130
10	4.5	6
19*	9.6	13
21	44.3	60
22	14.8	20
31	30	40
33	30	40
43	14.8	20
49	14.8	20
56	14.8	20
61	14.8	20

*Use Loctite 542 Red

DIMENSIONS

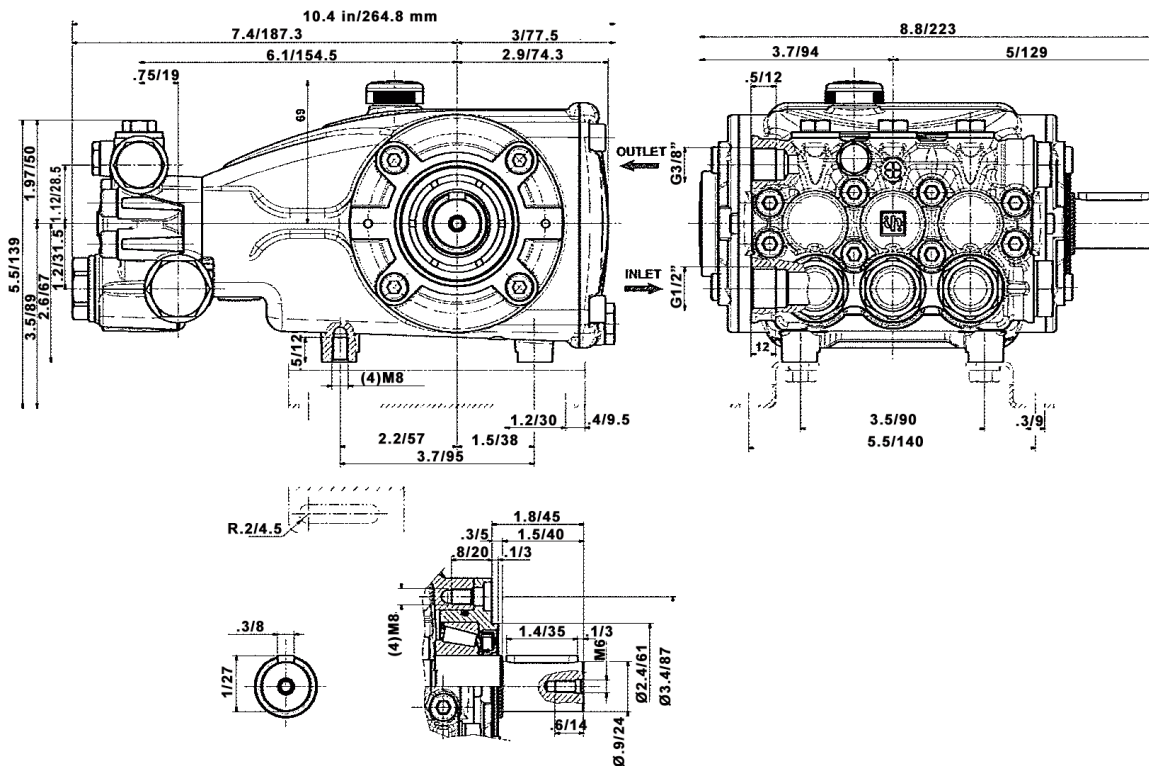

Ref 300951 Rev.C
01-16

