

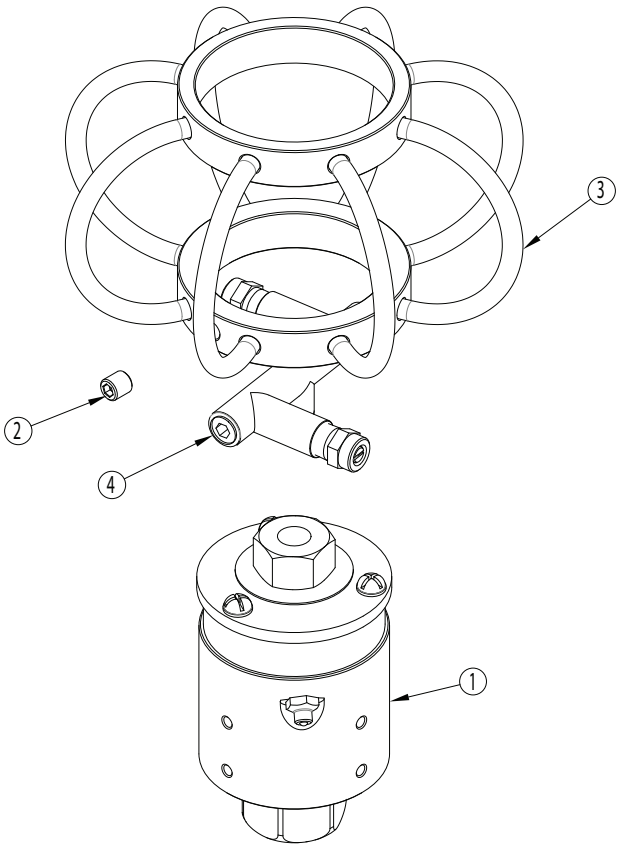

**FEATURES/BENEFITS**

- 1,500-4,000 PSI and 8.0 GPM
- Heavy-duty industrial duct cleaner
- Fully assembled, connects to high pressure hose
- (2) 25° x 2.0 nozzles
- Heavy-duty bearings (can be greased)
- Repair kits available

**PARTS LIST**



ITEM	PART #	DESCRIPTION	QTY
1	2103293	SWIVEL	1
2	2200111	SCREW, SET, M8	1
3	2103294	CAGE, DUCT CLEANER	1
4	2103295	NOZZLE, DUCT CLEANER	1
	2100372	REPAIR KIT (MAJOR)	
	2100303	REPAIR KIT (MINOR)	

Notes:

- Grease the swivel with one or two grease pumps every 200 hours (or about once every 30 days of use). Use No. 2 general purpose waterproof lithium grease. When using the swivel with hot water use good quality high temperature grease.
- When storing the swivel for a few weeks or months, it is best to drain as much water as possible from the unit. Disconnect the swivel from the pump hose and let drain. Shop air can also be used to force water out.

General Pump  
is a member of  
the Interpump Group

Ref 300998 Rev. B  
07-16



### 2103293 - SWIVEL BREAKDOWN AND PARTS LIST

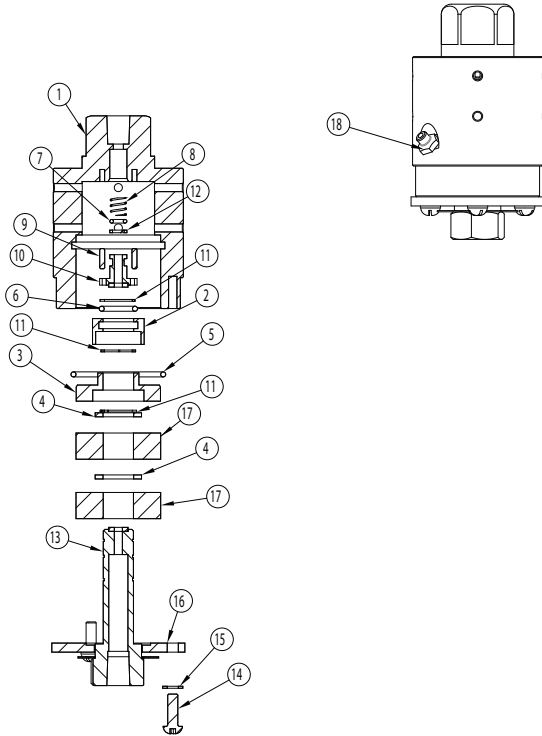

ITEM	PART #	DESCRIPTION	QTY
1	2500023	HOUSING	1
2*	2520030	RETAINER, BEARING	1
3*	2520028	RETAINER, BEARING	1
4*	2520027	SPACER, BEARING	2
5*	2701012	O-RING	1
6*	2701011	O-RING	1
7*	2701010	O-RING	1
8*	2720007	SPRING	1
9*	2530008	PIN	2
10*	2530007	STEM, SMALL	1
11*	2520029	SNAP RING	3
12*	2710000	BACK UP RING	1
13*	2520113	STEM	1
14*	2200092	SCREW, M5 X 16	3
15*	2200050	WASHER	3
16*	2500024	RETAINER, BEARING	1
17*	2640004	BEARING	2
18*	2640012	ZERK, GREASE	1
*	2100372	ITEMS INCLUDED IN MAJOR KIT	

### 2100372 REPAIR KIT INSTRUCTIONS (note: the use of a vice makes this process easier)

- Remove the arm from the swivel.
- Loosen the 4mm hex set screw on the cage and remove with arm.
- With the swivel base in a vise and the three screws facing up, remove the three screws.
- Grip the swivel stem with a plier or vise grip and pull the stem assembly out.
- Remove the small stem and spring from the inside of the swivel body bore.
- If the two dowel pins pressed into the end of the swivel body bore do not look worn they can be left in place. If they look worn, you need to pull them out and press in new pins. This can be difficult. Heating the outside of the housing helps to remove the pins, but this may discolor the anodize. Replace the pins with new ones supplied in the kit. Tap in with punch and hammer.
- Use an o-ring pick to remove the o-ring in the ID of the swivel body about half way down the swivel body bore.
- Replace this o-ring with the one supplied in the kit.
- A little grease on this o-ring helps the assembly process.
- Lubricate the o-ring on the new small stem with good quality grease, drop the new spring into the small center bore at the bottom of the swivel body bore, and then press the new small stem in the same bore on top of the spring. Be sure the slots in the small stem drop over the pins.
- Slide the new swivel stem assembly into the swivel bore and secure with the three washers and screws.
- The cage and arm need to be assembled at the same time; so place the arm inside the cage and drop the cage onto the swivel. Tighten the cage set screw. Use a good quality thread sealant on the nozzle arm threads and thread the arm onto the swivel.